

They Had No Part in The Work

Australia #2 - Tess Lambert 30-09-19

# Logic of the Line of Christ

Here is demonstrated the logic to show the line of Christ as being a key reform line to understand our own history.

We have the beginning and the end of ancient Israel. This is all the history of ancient Israel. First of all, the history of Moses, which we can plot on a reform line; then the history of Christ, which we also plot on a reform line. Alpha and Omega, the beginning and the end. All the history of that Alpha Glorious Land. This is the history of The Glorious Land.

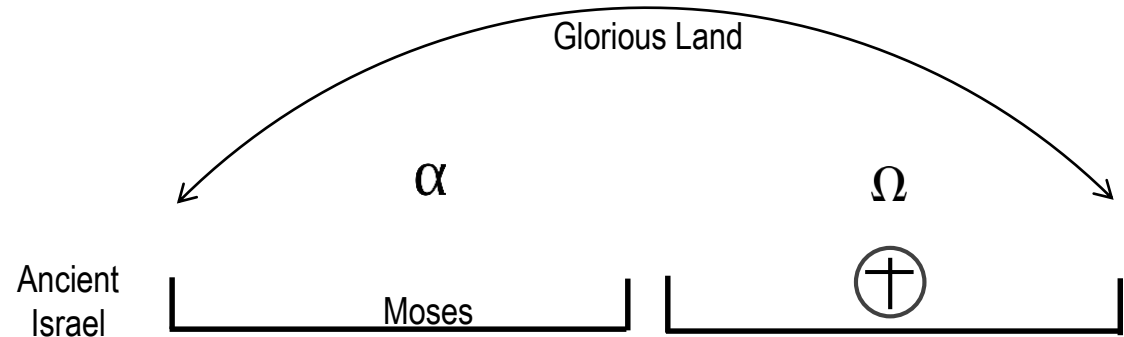

## Logic of the Line of Christ, continued

Now Modern Israel; again, God draws out his people. In 1798 you have the reform line of the Millerites which we plot on a reform line; it is the Alpha history, the beginning. Then the line of the 144,000, the Omega history, the end.

**Ancient Israel, modern Israel. Alpha Glorious Land, Omega Glorious Land. Beginning, and the End.**

We make application of the history of Moses onto our reform line as well as the Millerites. But when we construct our reform line in this fashion, **Ancient Israel, Modern Israel, failure, success**, then we see that the reform line that most closely illustrates our own is the history of Christ. So, we can take Christ's history, lay it over our history, to explain the events happening around us.

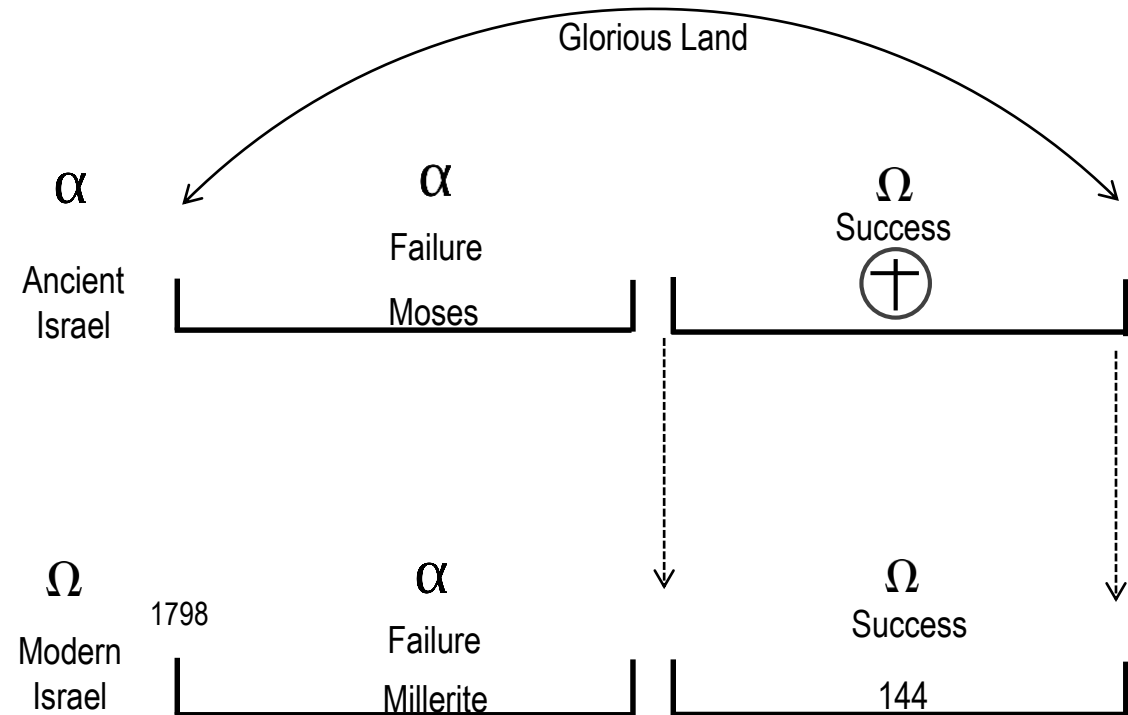

# Logic of the Line of Christ, continued

We understand that in our history God calls out a people in three parts, first of all the priests, then the Levites, and then the Nethinims. First group, second group, third group. We took this concept of the construction of our reform line, those three groups, we looked into Christ's history and we see the same thing. The third group, when they are harvested, when we go to the Nethinims this waymark is the Sunday Law. So, when we go to the history of Christ, we find that again there are three groups. First of all, the disciples are called, then they go back to the church, and then they go to the Gentiles. At this point, when the Gentiles begin to be called, we went to the Spirit of Prophecy and history and we see that at 34 A.D., the stoning of Steven, they begin the work of taking the gospel to the Gentiles. This waymark of Sunday Law is a shut door for Adventism, the institution. This waymark, 34 A.D., is the end of the 70-year Prophecy; it is a shut door for the Jewish Nation. So, we can see that 34 A.D. lines up with the Sunday Law waymark.

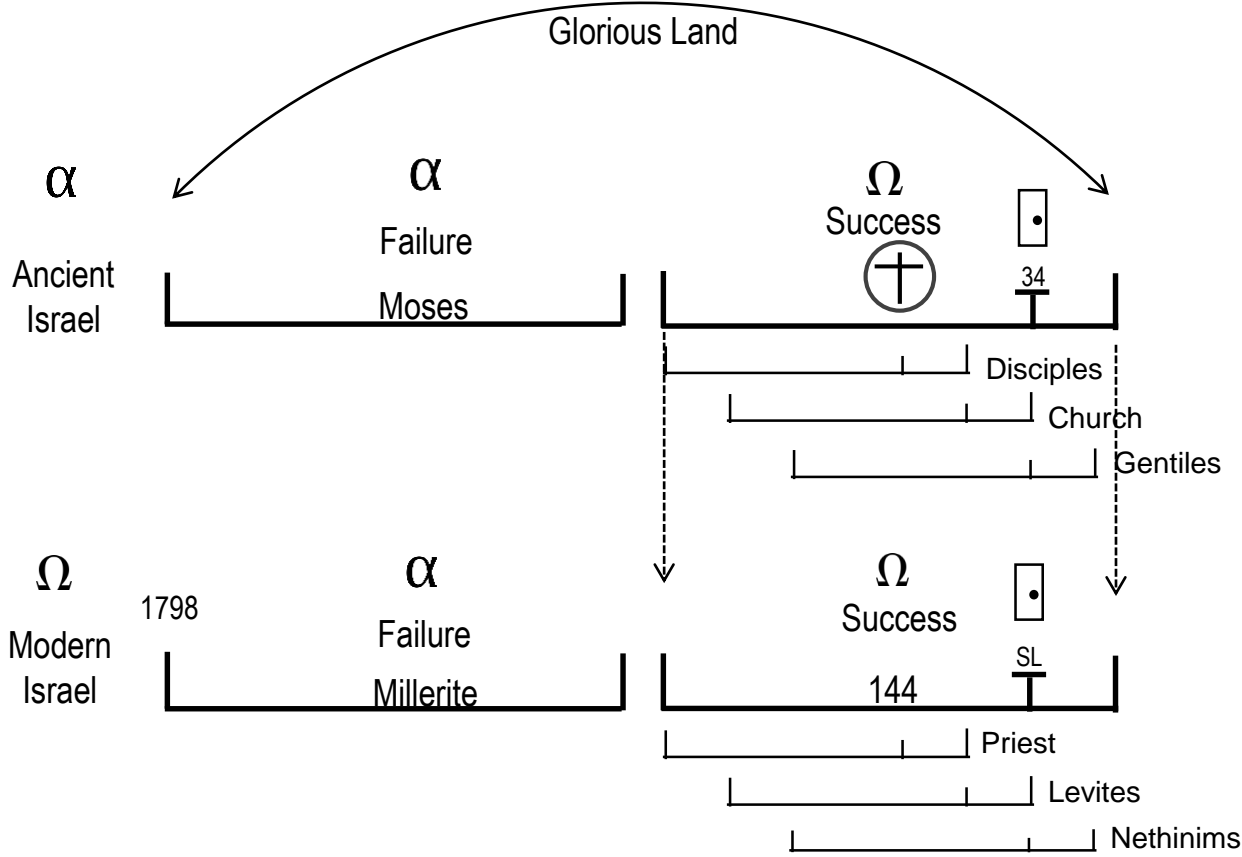

# Logic of the Line of Christ, continued

Then we can work backwards, if Sunday Law or 34 AD is when the gospel goes to the Gentiles or the Nethinims, then at Panium the gospel goes back to the Church or the Levites, and that work begins at Pentecost. So, Pentecost becomes Panium, the Midnight Cry, depending on the line you're considering. If the gospel goes back to the church at Pentecost, we go back from Pentecost and we find the cross, the great test for the first group called, the test for the disciples. You go back from Panium and then you come to Raphia, this is 2019, the great test for the priest.

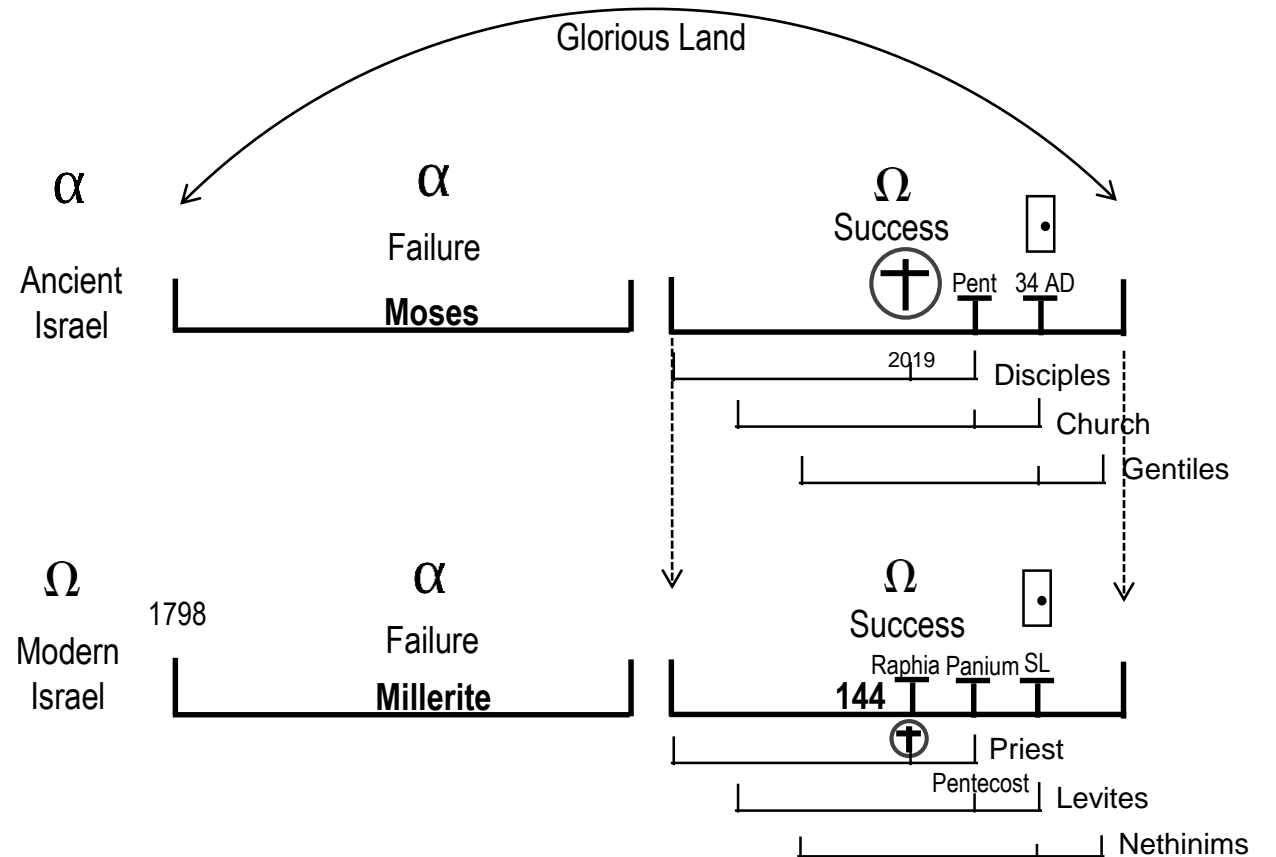

# Logic of the Line of Christ, continued

We have combined our histories, this history of the Cross is Raphia, is 2019. This waymark of the Midnight Cry, Panium, is Pentecost. This waymark of 34 A.D. is a shut door. Sunday Law is a shut door. So, we went to the history of that first group called, we are considering the disciples. And when we are looking at the history of the disciples, we find that it all begins at the time of the end. And then they go through two histories, which you can divide up, first under the administration of John the Baptist and then the administration of Jesus. They are under the ministrations of Jesus, the second messenger, and they come to the history of the Cross and we see them shaken and divided. And we asked the question, are they shaken and divided before the cross or after the cross? And we know from that gospel history that the great rebellion against Christ, the division of his disciples, occurs before the cross, not during and not after.

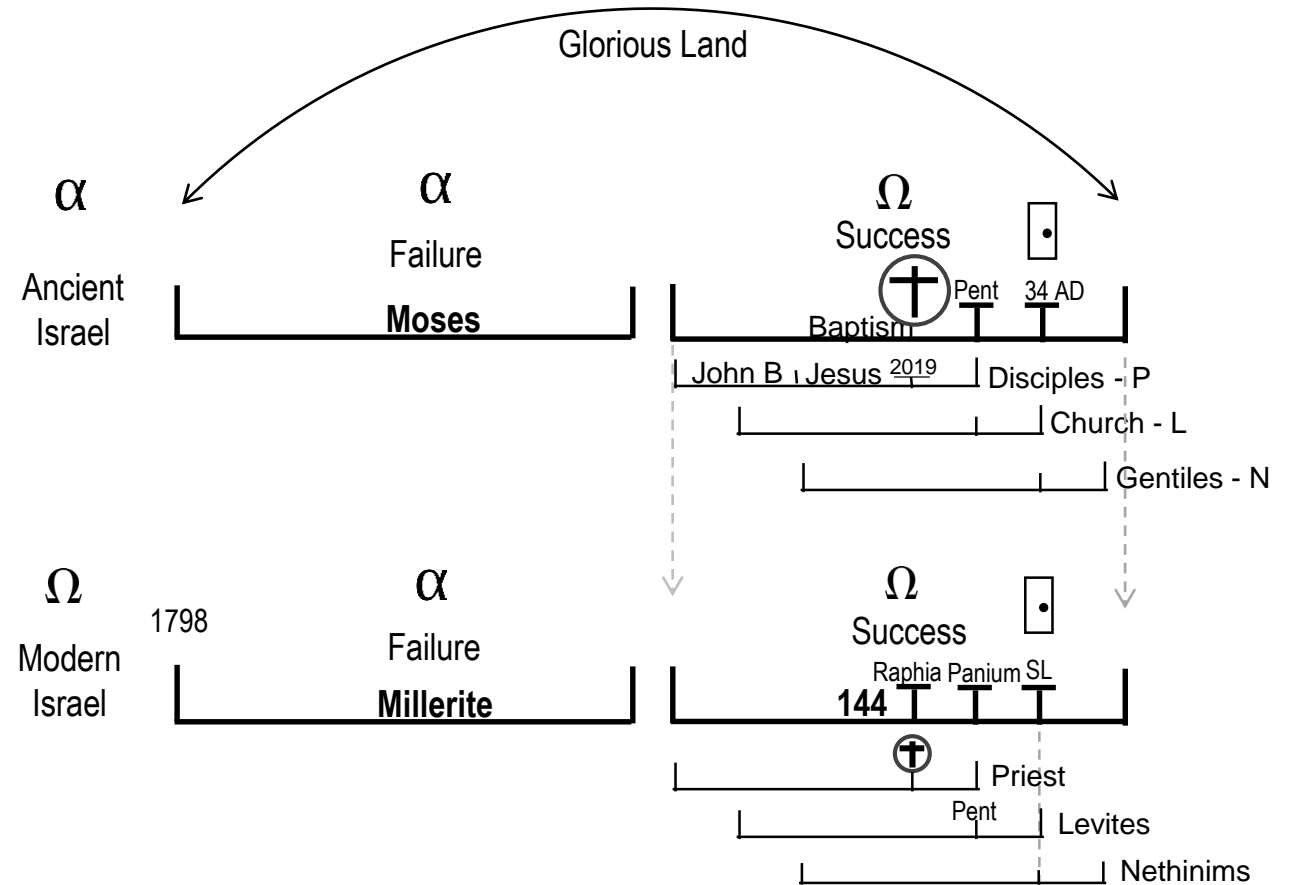

# Great Rebellion

We took this concept of this history, of the Cross representing 2019, our Close of Probation, and we saw that it is the Great Rebellion. From the ministration of Jesus, which begins in 2014, to the Cross which is 2019. We saw that on this side of the Cross there's a shaking and there is the last Great Rebellion for this group of people. They are divided over whether or not they accept Jesus for who he is and his message. We took this concept of the last great rebellion and brought it to the first Great Rebellion in heaven, and then we paralleled those two histories. We went to the Great Rebellion in heaven and we saw that at this Great Rebellion, we are taking it from here in 2014.

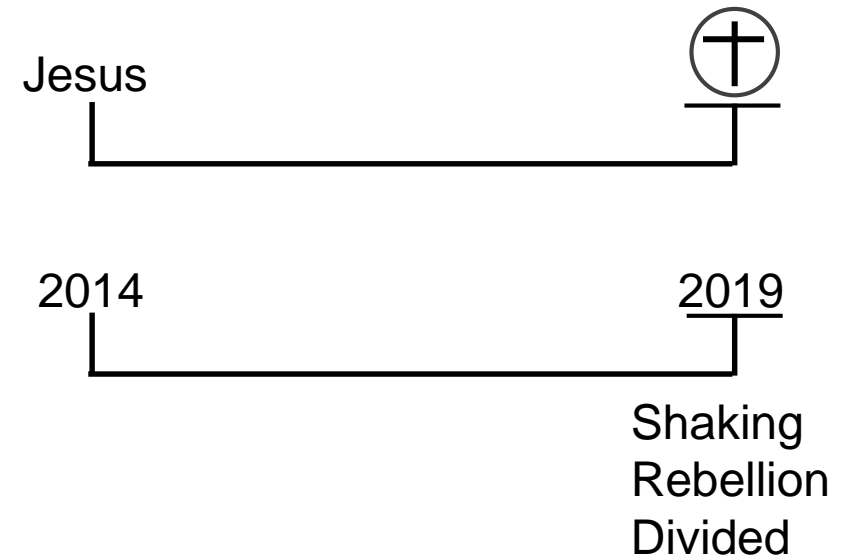

## Great Rebellion, continued

You had equality already put into place, the Father and the Son. This equality is hidden. At a point in time they decide that they are going to build the earth and there is a meeting between the Father and the Son. And everyone can see that they are now beginning to work together as equals. When they begin to work together as equals it begins to create dissatisfaction in the heart of Lucifer. He sees that the two working together are the Father and the Son, and he says, Why not myself? Why is Jesus working with the Father, when I should be equal with the Father? Lucifer already believes that he should be on an equal footing with the Father and brought into all of that planning; instead God goes to communion with the Son and they begin planning. It comes to the point where God the Father decides to call all the angels together to make it official, an official Proclamation that he ordains that the Son is equal to himself. They were equal from the beginning (Ellen White makes that clear), but now he says you must all recognize the Son is equal in authority with myself. At this point in time, the Rebellion already building, breaks into the open.

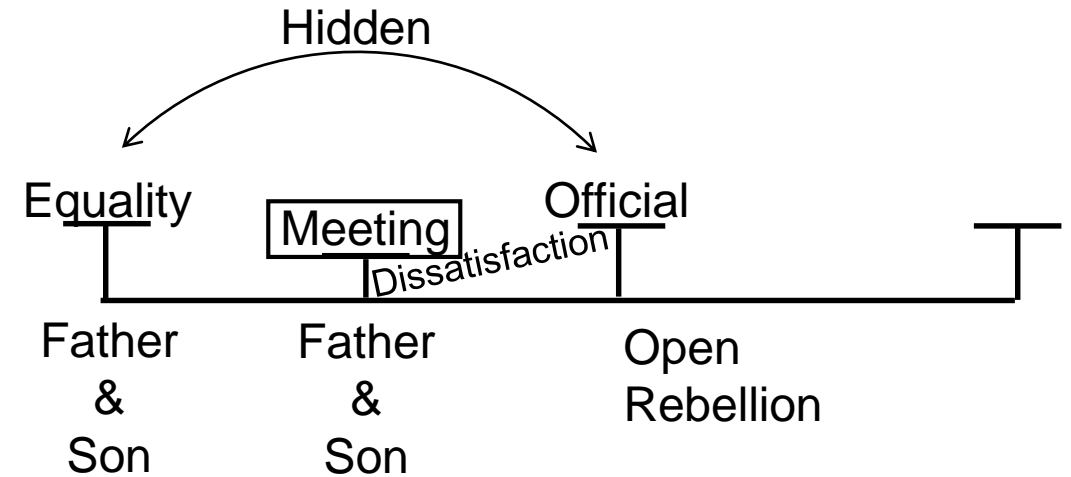



## Great Rebellion, continued

Lucifer begins to consult with the angels. He uses deceptive reasoning to convince them that this government is not fair or righteous and that he can build a government under himself that will better the angels, give them better freedom. For now, it descends into open warfare between the Father and the Son and Lucifer. Lucifer by his deceptive reasoning when he condemns God's government, the working together of two equals, begins to bring over to his side the majority of the Angels. More and more of them start accepting his logic but then God begins to answer them. And, some of those Angels come back to the right side.

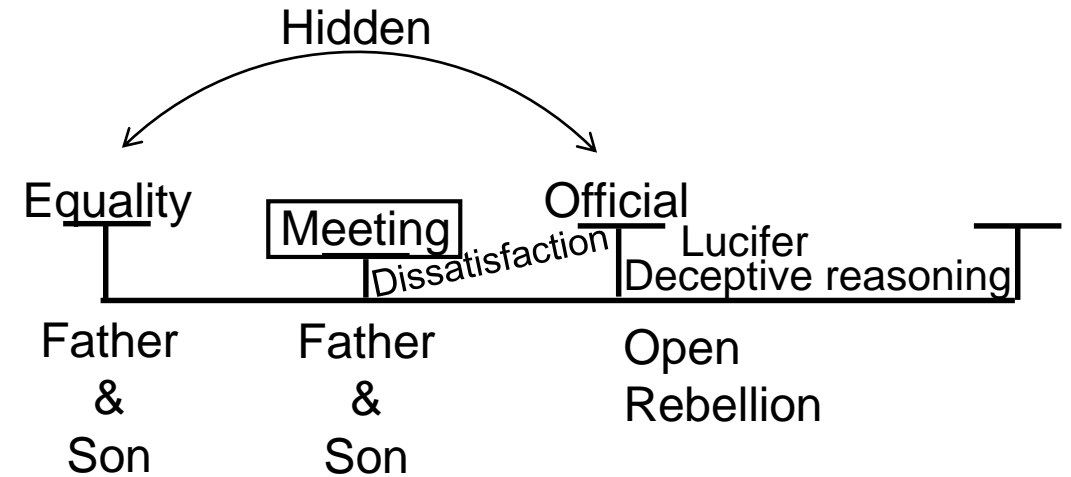

## Great Rebellion, continued

From 2014 there is equality; there are already prophetically two leaders that are equal in this movement, but it is hidden. No one knows. It comes to a point in time, October 2018, where it can be seen that those two leaders are working together in plans that not everyone is aware of. This begins to cause dissatisfaction in the heart of Lucifer; this is allowed to grow and develop until 2019 at the German Camp Meeting where it is made official that these two leaders are equal and one is to be ordained. Now the Rebellion breaks into the open within hours of that being put into place. And then we find deceptive reasoning beginning to divide two classes of angels and this movement begins to divide into two groups, the wise and the foolish. It's opened up into an Information Warfare. And one group will be cast out of this movement.

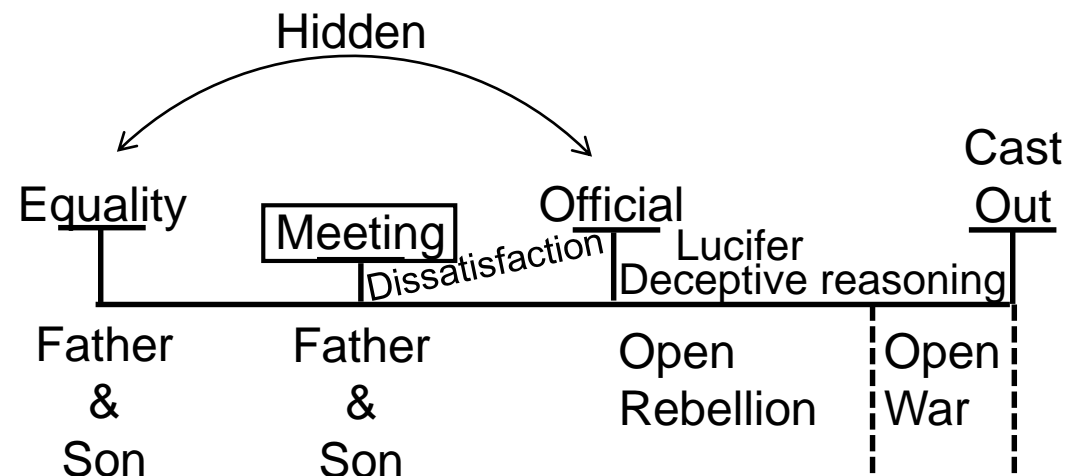

# Great Rebellion, continued

It's up to you to see the parallels and see for yourself what side you want to be on. I am not saying that because we are a majority that that makes us somehow safe, but I'm not convinced we're going to stay a majority. It was not a majority that stood with Jesus, but it also was not a majority that stood with Lucifer to the end where they were cast out. So, there is no safety in saying we are on the right side because we are the persecuted minority. At the point in time where Lucifer and his Angels were cast out of heaven you didn't want to be on the minority. On the side of Christ, if you are one of the disciples, you might want to be on the minority.

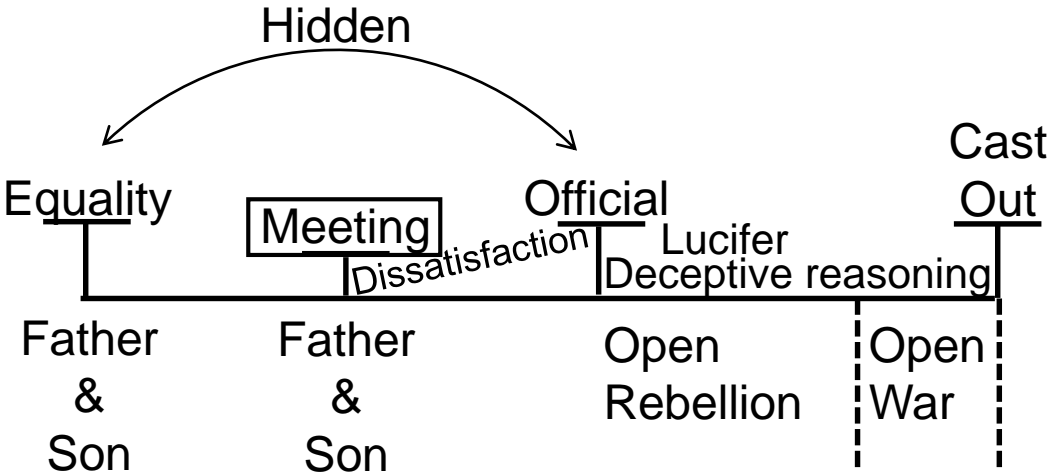

## Great Rebellion, continued

We reviewed the history of Christ, how it lines up with our own history, how they have this Great Rebellion, the Final Rebellion, for the priesthood before their Close of Probation. We lined up the Final Rebellion with the First Rebellion. We saw the path of Lucifer. At the beginning all was in harmony, from 2014 all was in harmony. There comes a point in time when it is recognized that there are two equal leaders. It is here that dissatisfaction is sown and that continues to grow and develop until the fact that they are two equal leaders is officially put into place. Here the Rebellion breaks into the open and you have a division between the angels who sides with what leadership.

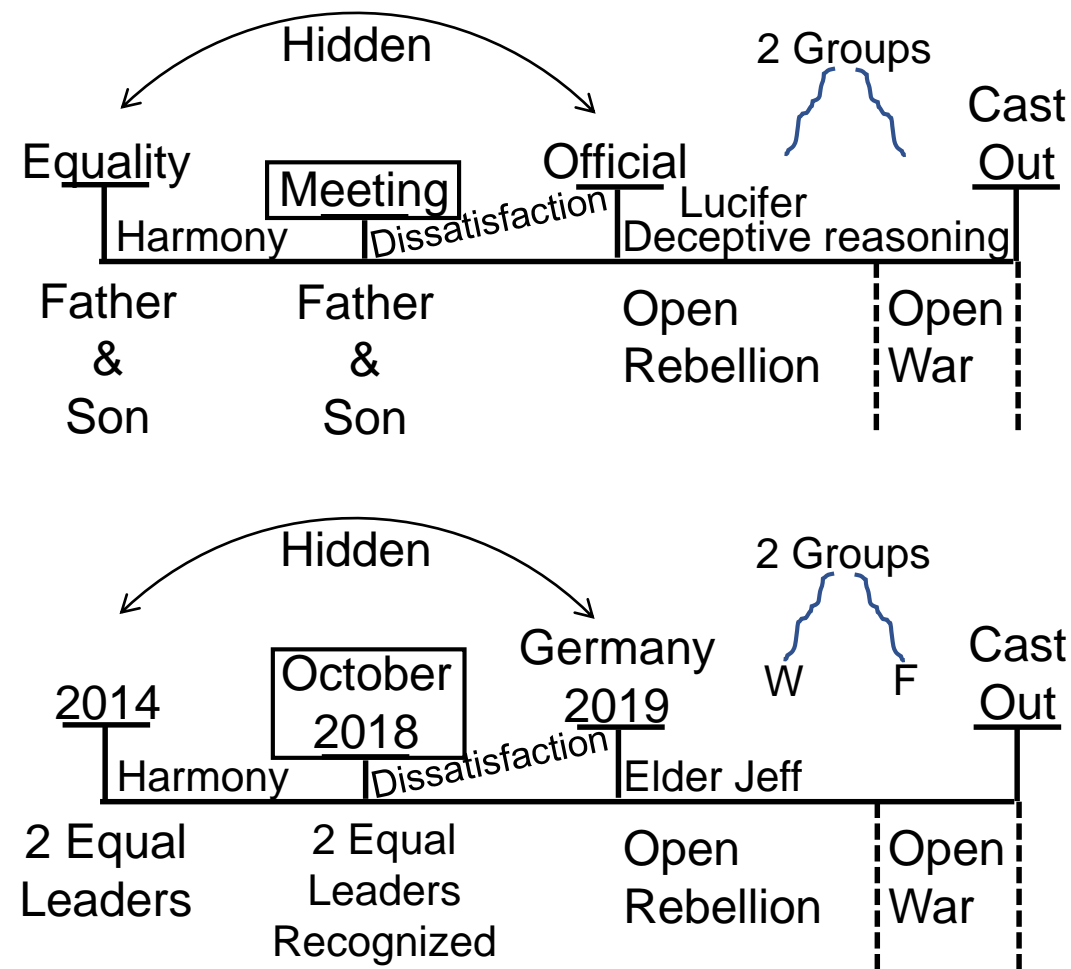

## Great Rebellion, continued

The test all through that very first rebellion in history is all about equality. The equality existed before but it was hidden; it began to manifest itself when the two co-leaders began to work together. Lucifer had thought that he would work with the Father as an equal, instead someone else has taken that place. This begins a rebellion in the heart of Lucifer that must grow until it exhibits itself. The Father gathers the angels to make a proclamation so that there is no longer any confusion over this issue. Jesus sits with him on his throne and is equal co-ruler of the universe. The Rebellion breaks into the open; his deceptive reasoning gradually wins him the support of about half the Heavenly Host.

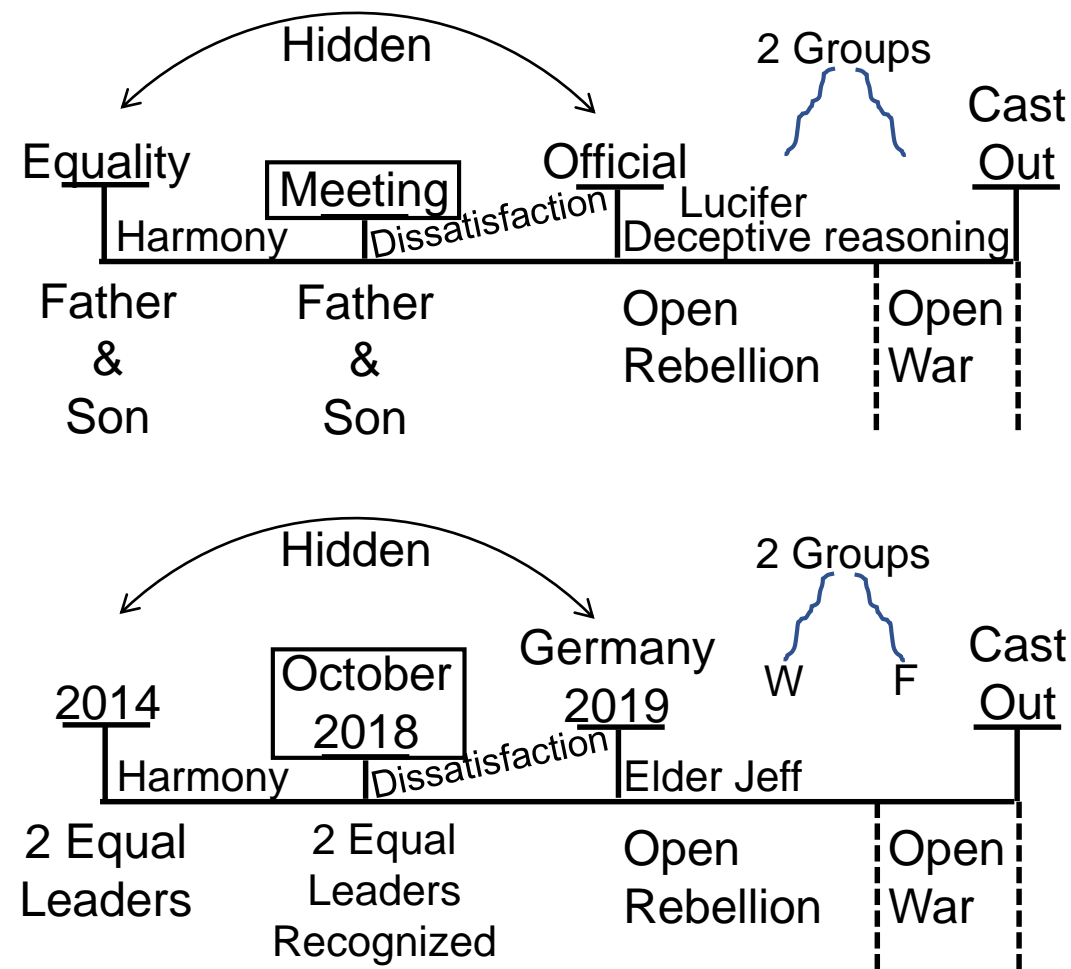

## Great Rebellion, continued

His false representations quoting from the signs of the times won to his side one third of all the Heavenly Angels. This is at the endpoint and so strong was their delusion that they would not be corrected. They clung to Lucifer. Lucifer had such an influence over the Angels because he was greatly beloved by them. He was the light bearer; he brought light out of darkness and he moves from being the light bearer, Lucifer, to Satan, the rebel. Quoting Elder Jeff, he says, I still stand by that, brothers and sisters, I still think Parminder is the second angel. His issue was not with the second angel in his history, his problem, his issue is when the third begins to be introduced.

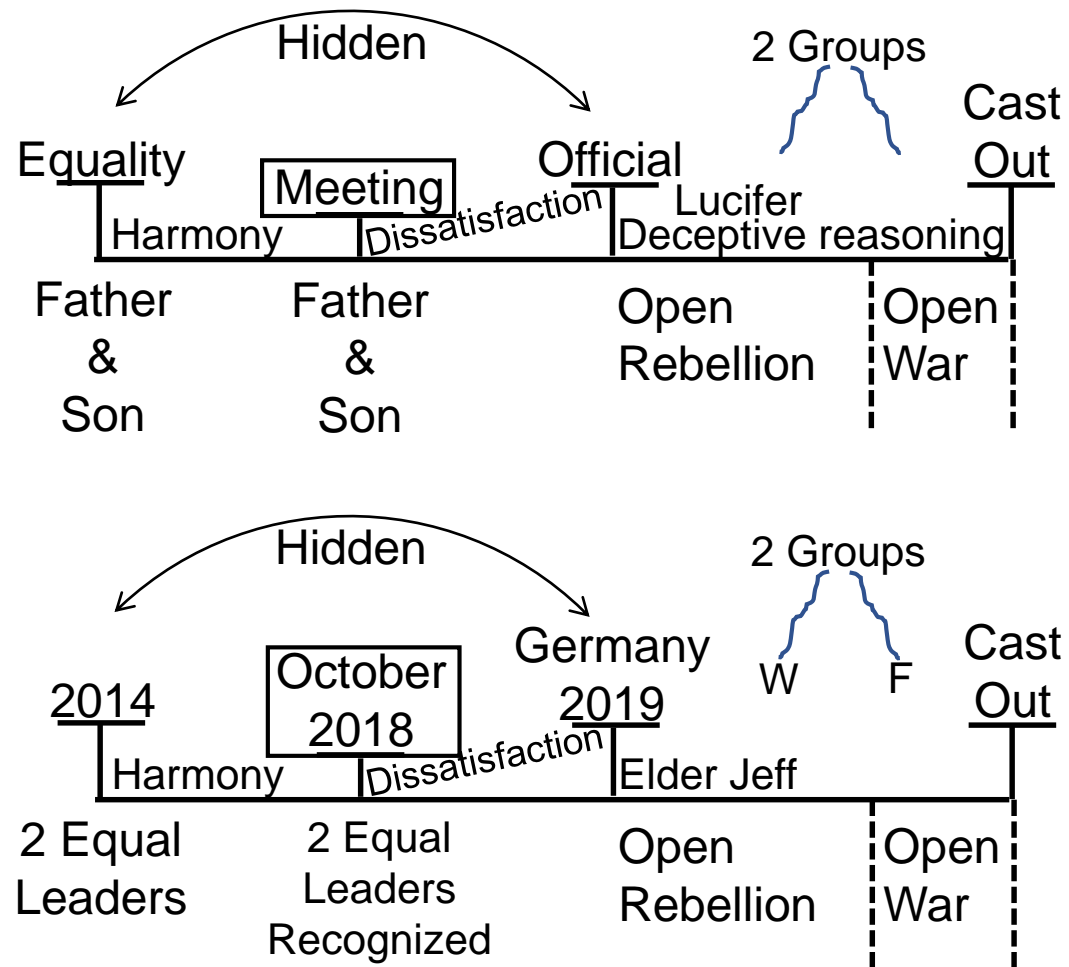

# Hand of God

I want to put something in place that we're going to refer to later. You have the line of the 144,000. Five key waymarks, the hand of God gathers his people: 1989, 9/11, Sunday Law (the midpoint / midnight), Close of Probation, Second Advent. What we came to recognize with these five waymarks is that they bookend four histories, and in each of these four histories there is a message that is unsealed, then there is an increase of knowledge, a formalization of the message, and a test, and a shut door, and then that process begins again. Message is unsealed, increase of knowledge, formalization, test, begins again. Increase of Knowledge, formalization, test. It is a repeating pattern through each of these four histories. Elder Jeff has said that he has no problem with this repeating pattern. He said it fits; it is powerful. If we focus on this history of Sunday Law to Close of Probation, this would be Boston, Concord, and Exeter.

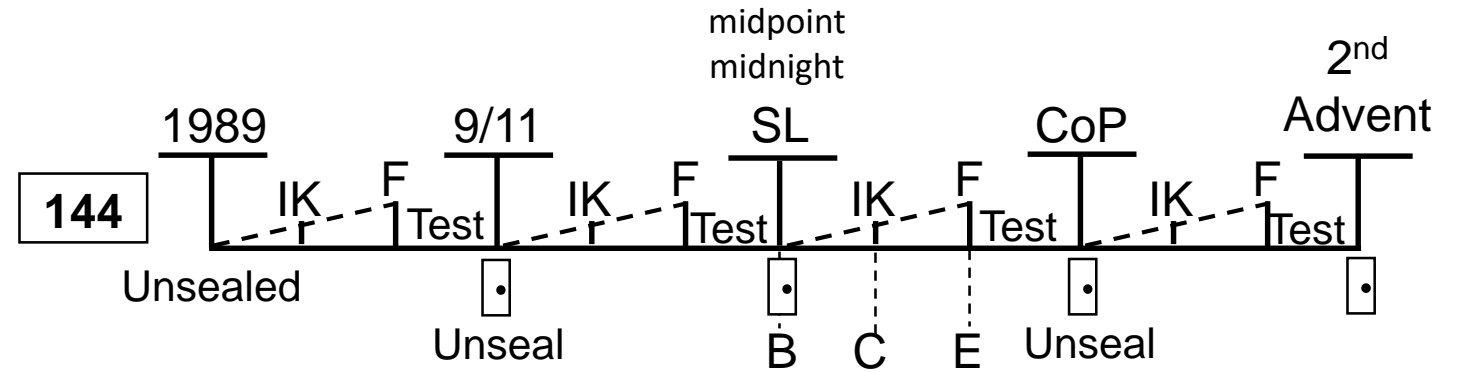

# Hand of God, continued

If we take that to the line of the priests, we have marked to the same pattern, 1989, 9/11, 2014, 2019, Panium. We can expand this history, Boston, Concord, Exeter, in every dispensation; we can expand this history, each one of these in the same way. I will just take ours; we could say 2014, there's a message unsealed. The message is unsealed, there is an increase of knowledge about this message, it is formalized, and then there is a test, and a shut door. This is the repeating pattern. Some people have an issue with saying I am a co-ruler in 2014, because for those that are aware, I was not a part of this movement in 2014. I was a normal Adventist. And they say therefore how can she be co-ruler of a movement.

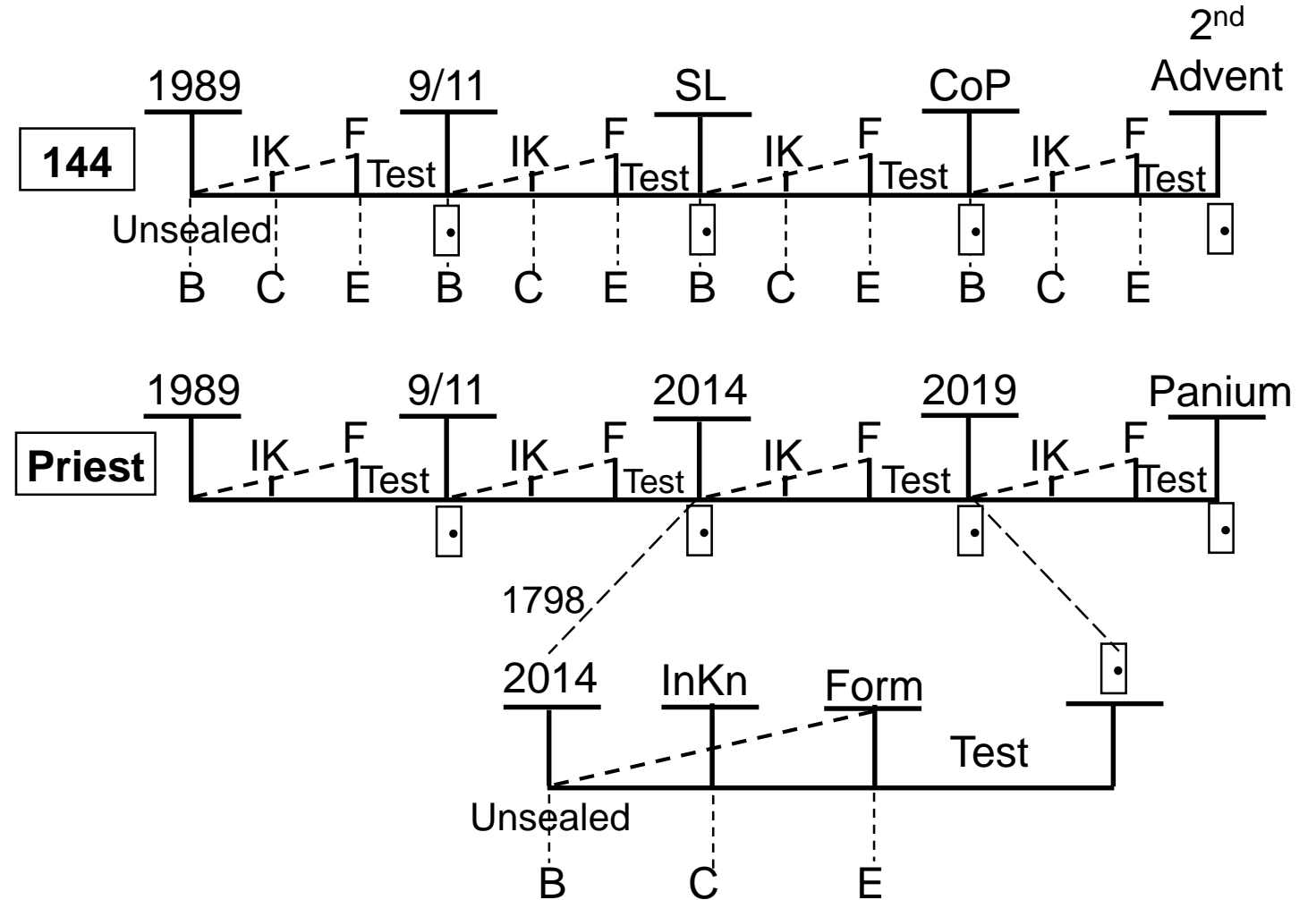



# Hand of God, continued

Question. This is the time of the end, this is the time of the end, this is the time of the end, take it back to 1798, William Miller is raised up in 1798 and we already identify him as the leader of the movement. Question, he is barely a Protestant, he is a deist in 1798 and for some time afterwards and yet we still identify him as receiving this unsealed message and being the leader of that movement before he himself is aware of it. So, that is not a concept unfamiliar to us. I'm going to leave this on the board and will refer to it at a later point in time.

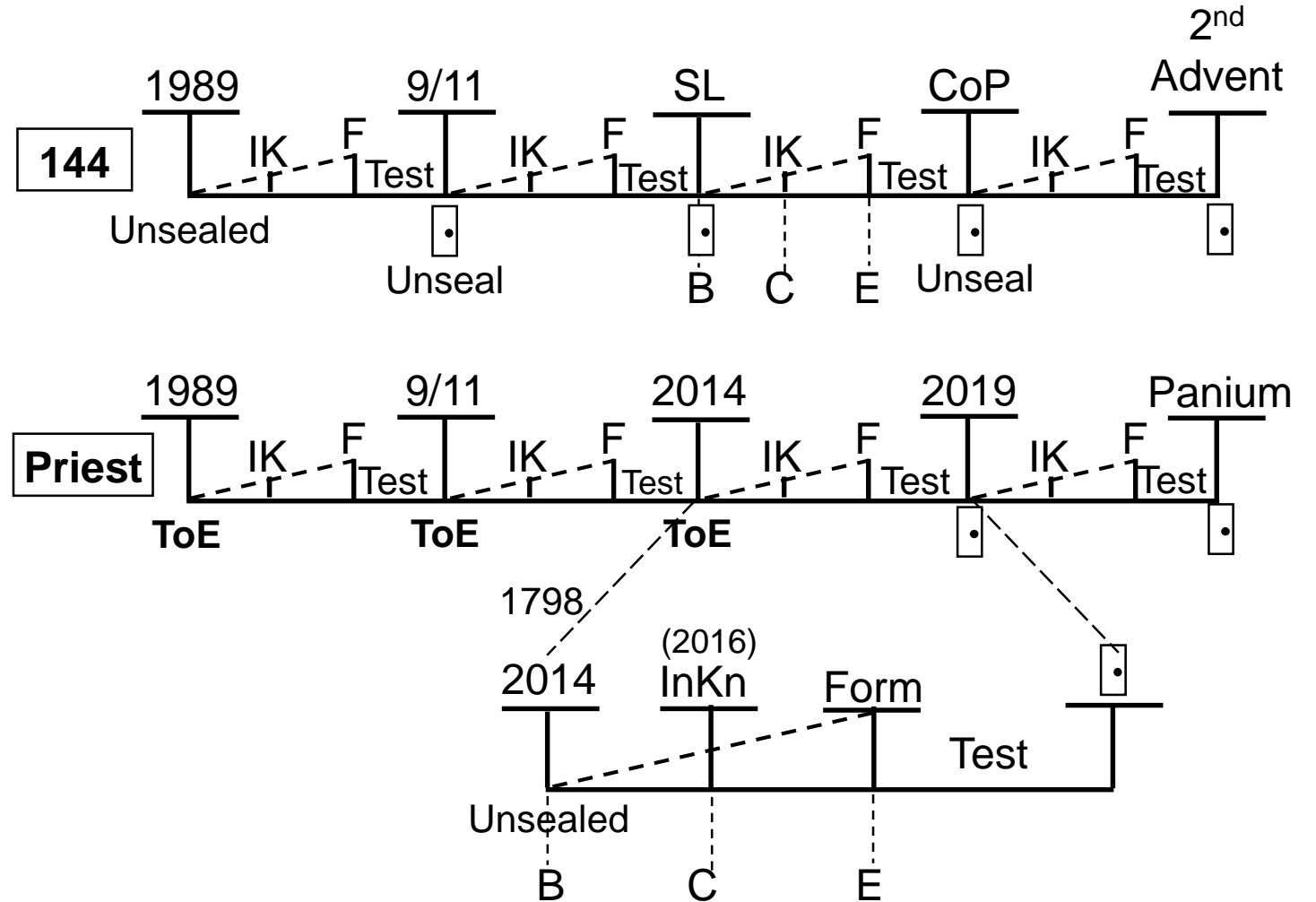

# Jesus Represents Leadership And The Movement

What I want to do in these couple of presentations is remind us of where we've come from. It won't all be new information but I hope for everyone it will put what you already know in a more solid framework. We talked about the history of Christ; we did that in this revision. And we showed how Christ represents the second leader or second leadership; you can see that in every history whether you go from Moses to Joshua, Elijah to Elisha, Miller to Snow. Every reform line illustrates to us that there is a second leadership. But Christ represents more than individuals.

## Jesus Represents Leadership And The Movement, continued

One of the truths laid out last October [2018] was when we construct His reform line, we can make another application. We can see His birth at the time of the end, 1989, then for twelve years He is developing, then 9/11 at the temple. Twelve years and then eighteen years. Twelve years He is developing as a child and then he goes into active industry, the work of carpentry, of construction, and for the whole 30 years He is in training, which takes us to 2019. Jesus is 30 years old, He is baptized, and He is being prepared for 30 years, the number of years a priest was to develop and train preparing to go into work as a priest. This is the story of the priesthood as illustrated in the life of Christ.

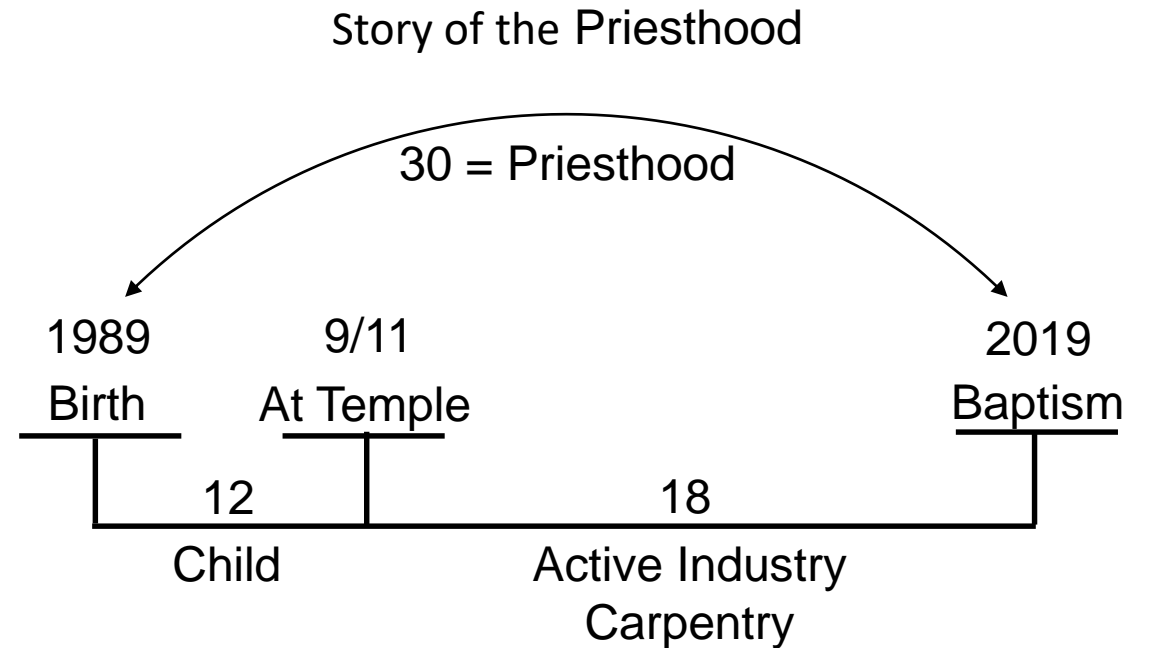

# Jesus Represents Leadership And The Movement, continued

So, Jesus, He doesn't just represent leadership, he also represents the whole of the movement and that's what I want us to focus on today. On Sabbath we defended the position that there are two co-rulers and that Jesus represents the leadership. We can reinforce that point with multiple reform lines but I want us today to focus on this point, that Jesus also is representative of the movement itself.

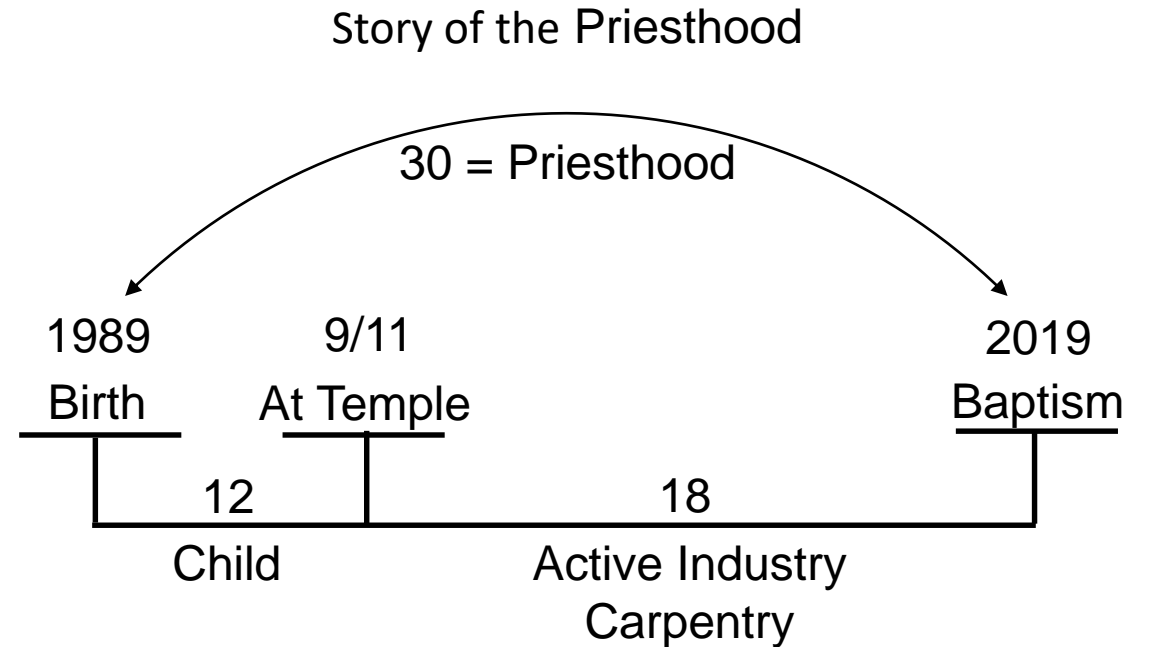

## Jesus Represents Leadership And The Movement, continued

Christ represents the movement itself. Then when we go to His history and we see we are at the cross, we can go back to Matthew 26 which we referred to in our previous study and we see false accusers condemning Him. To these false accusations Jesus makes no comeback but the high priest arose and he challenges him saying cannot you hear all these false accusations, tell us who you are and Jesus responded to the high priest by saying, you have said, nevertheless I say unto you, hereafter shall you see the Son of Man sitting on the right hand of power and coming in the clouds of heaven.

*According to Desire of Ages, page 726, "Standing behind Pilate in view of all in the court Christ heard the abuse but to all the false charges against Him, He answered not a word. His whole bearing gave evidence of conscious innocence. He stood unmoved by the fury of the waves that beat about Him. It was as if the heavy surges of wrath, rising higher and higher, like the waves of the boisterous ocean, broke about Him, but did not touch Him. He stood silent, but His silence was eloquence. It was as a light shining from the inner to the outer man."*

The moral attacks and the mudslinging we have no response to, we are to rest on the prophecy. But Jesus as representing the movement gave a response to that accusation to the appeal of Caiaphas, Christ could not remain silent there was a time to be silent and a time to speak. His own relation to the [27:00] father had been called into question and he must plainly declare his character and his mission.

This is not just true on an individual leadership level; what I want us to see is that Jesus represents the movement. And it is the movement and God leading of it that I want to defend.

# Testimony of Elder Tess

So, we are going to walk through history; we are going to walk through this dispensation of 2014 to 2019. In 2014 a message is unsealed, in 2016 there is an increase of knowledge, in 2015 I entered this movement. I entered the movement when [28:00] attending a camp meeting held by the Australian Ministry where Mark Bruce was the teacher.

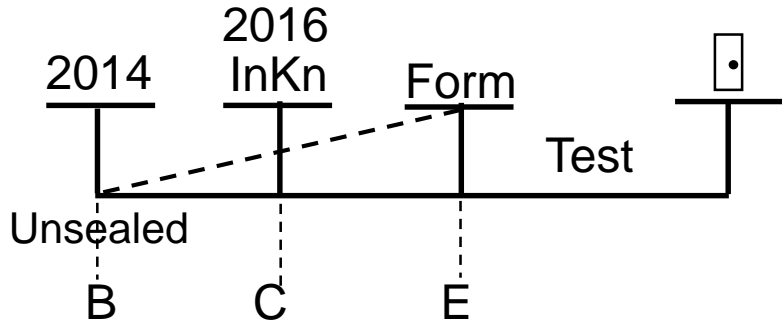

## Testimony of Elder Tess, continued

Mark Bruce laid out line upon line and fractals and even though it was challenging to understand as someone who had not yet heard much of this movement it resonated. It had the ring of truth and I joined the movement. In 2016 around September Elder Parminder came to Australia and held further camp meetings. In 2016 it is the increase of knowledge, the months of October and November. I was watching a presentation by someone who has since left the movement, this person was in the process of leaving the movement when he taped this presentation at Future for America at the School of the Prophets they had not yet split. At this point in time he is in Rebellion to the movement, so he makes the claim in his studies that we must search for ourselves and not let any human being lead us. He said that because at that point in time he was in the process of leaving the movement of rebelling against the leadership and was attempting to draw support away from the leadership of this movement to himself. Now you see Future for America and Elder Jeff make the exact same point; don't follow human leaders, follow the truth, study for yourselves. It is always the point made by those separating themselves from the movement. Most of what he said, really all of what you said, made no sense to me; but there is one thing that he did say, that call to study for yourself and I did want to study for myself.

So, I began to search through the Bible for symbols and for those symbols to take me somewhere where you could see a line or prophecy open up. And I searched for Midnight in e-Sword, it came to Acts 27:27; *“But when the fourteenth night was come, as we were driven up and down in Adria, about midnight the shipmen deemed that they drew near to some country;”*. It is October-November of 2016 and Acts 27 begins to open up symbols that started to emerge all through the chapter of Acts 27 and the surrounding chapters.

# Testimony of Elder Tess and Acts 27

So, the first light that opened up was 2016 and it was a study of Acts 27. What opened up was a story of two ships. You had the ship of Adramyttium and the ship of Alexandria. The ship of Adramyttium abode in death. You could begin it from 1989, 9/11, Panium or the Midnight Cry, to Sunday Law or the Shut Door; that will be familiar language to those who are aware of our studies on the fifth line. That Sunday Law is a Close of Probation for the **Institutions** and in that line Panium becomes a Midnight Cry. The ship of Alexandria took us from 1798 through the Sunday Law, shipwreck. That was a study that first opened up into Acts 27.

I want us to remember this first line, the ship of Adramyttium, 1989, 9/11, Panium or the Midnight Cry, Sunday Law or the Close of Probation, because we're going to come back to this. It was the first truth open in relation to this message.

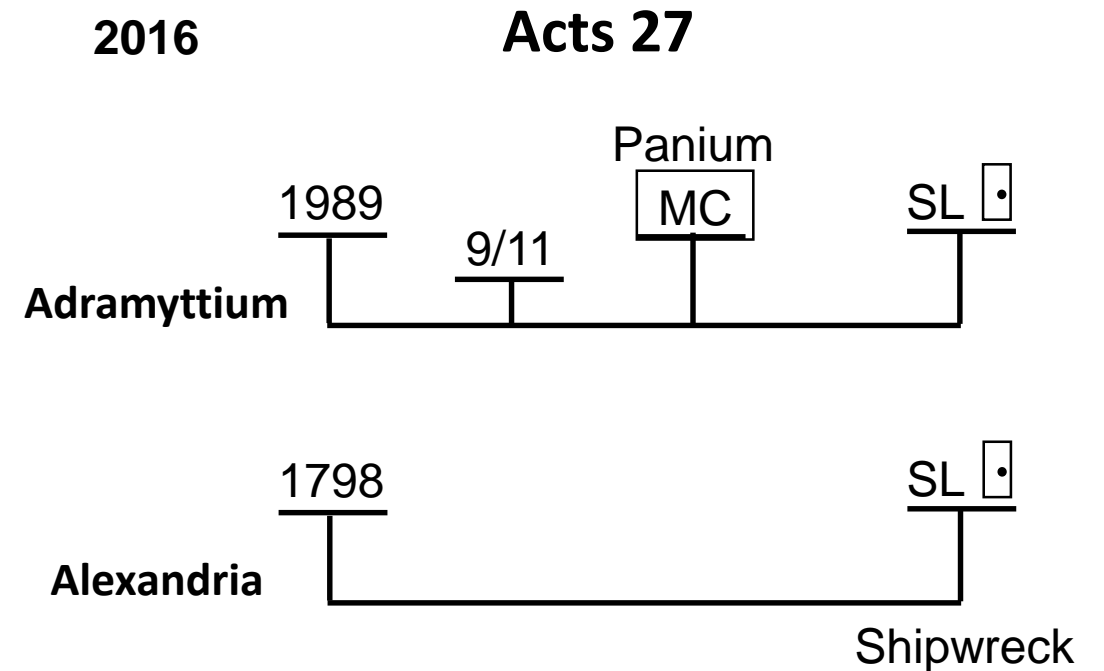



# Testimony of Elder Tess and Acts 27

I began to be perplexed by this ship of Alexandria and some of the symbolic language being used particularly the number 273 and why that detail was recorded at that point in time in inspiration. It was studied out for some weeks but one morning it opened up.

I will quote a couple of familiar passages.

*“Rome’s defeat of Pyrrhus was a clear declaration to the rest of the ancient Mediterranean world that the Romans had arrived on the world scene of warfare and power politics and recognition of this fact was no long time in coming in 273 BC Egypt and Rome come into Union.”*

*“In 273 BC Ptolemy of Egypt established diplomatic relations and friendship with Rome.”*

That's two different sources and we could go to others to show how in 273 BC there is this union, this coming together between Egypt and Rome. This opened up a study of the Pyrrhic War or of Pyrrhus.

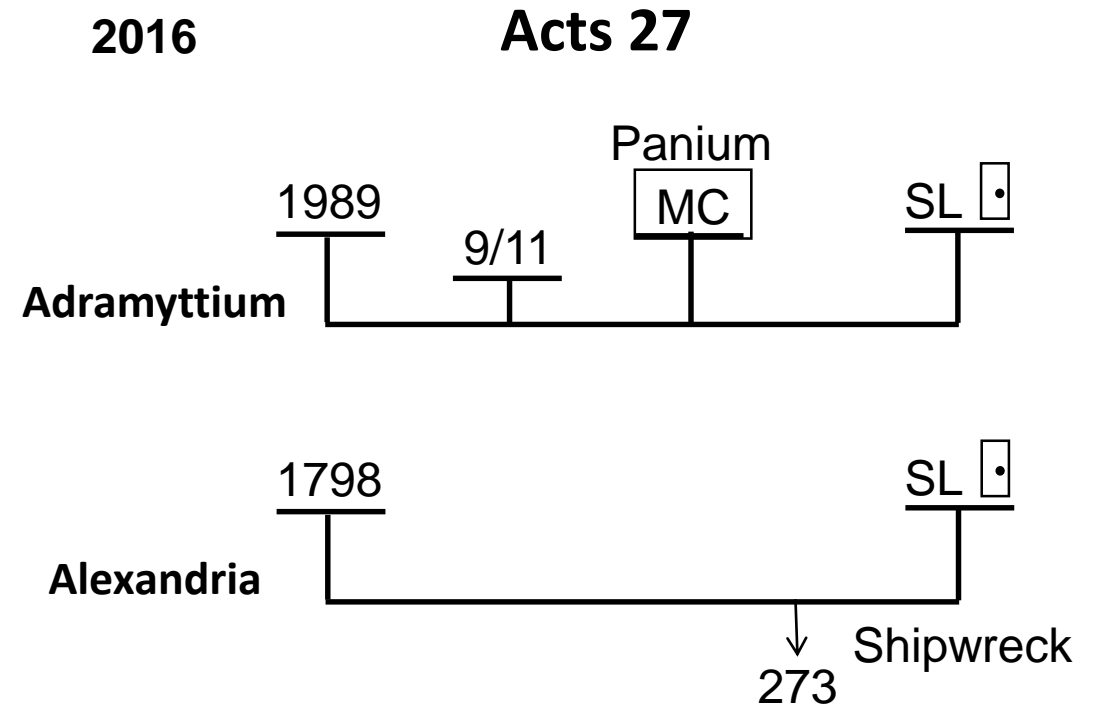

# Pyrrhic War

So, from Acts 27 it goes to the 273 and then a study on the Pyrrhic War. This study of the Pyrrhic War begins to show a history where there is war between the King of the North and the King of the South. I began to recognize that this war had parallels with our own reform line. It is the history of 285 to 272 overlaid with our own history of 1989 to Sunday Law. All of this had opened up although not yet the studies continued to be developed. But they all opened up in the final months of **2016**. In the early months of 2017 both these subjects were presented in Australia and recorded. They had not yet been completed to their full application but enough to be presented and recorded. In July of 2017 I attended ACE in Wales; I arrived a few days earlier than most of the other students which, although not intentional, provided an opportunity to have a discussion with Elder Parminder. And I laid out the studies of Acts 27 and Pyrrhus that I had been considering. What he suggested was that this is an interesting history with Pyrrhus, why not go further back; go backwards and see whether or not there are more details you can bring up into this reform line. I began to do so.

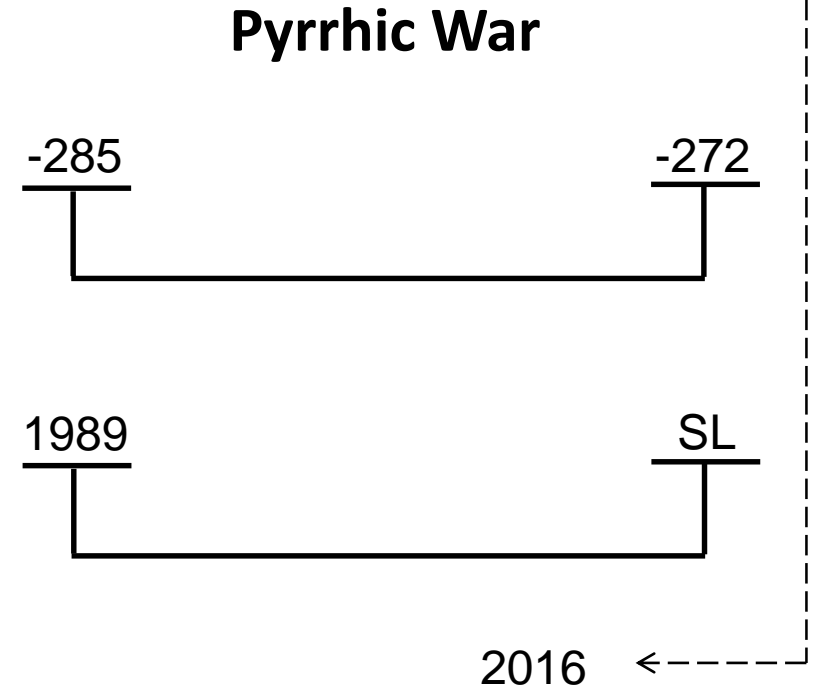

# Testimony of Elder Tess and Alpha and Omega Histories

What then began to open up was that first history. When it comes to the history of Pyrrhus, an Alpha in Macedonia and an Omega in Italy, that there is an Alpha and Omega history. And it was seen that the characteristics of these histories connected with our understanding of World War II and what we have referred to as World War III.

So, first of all, Acts 27, was in the last final months of 2016. Next the line of Italy overlaid with our own reform line and then after that the history of Macedonia and World War II. As these studies were developing it became clearer that there was also a connection with the country of Epirus and its leaders themselves.

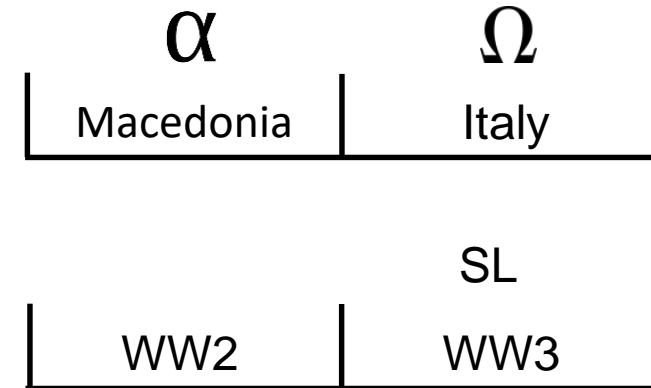

# Leadership of Epirus

So, another study developed into the leadership of Epirus and it was recognized that when you plotted the leaders of Epirus on a reform line you could see that from the first, Admetus, all the way to Pyrrhus it formed a particular pattern, co-rulership and he returns. And then when you bring that to the King of the South in our day it followed the same pattern, an end from the beginning. We were able to see that not only did Pyrrhus represent Vladimir Putin, now it became much more strongly defensible. That also, going back to the beginning, you could connect Putin to Stalin, Alpha and Omega, the first and the last, Admetus, Pyrrhus, Stalin, and Putin. When you understood them in that fashion, we understood that Stalin in the history of World War II typified Vladimir Putin. Now what we can do to understanding the leadership of these countries is to cut the line and combine the Alpha and the Omega histories.

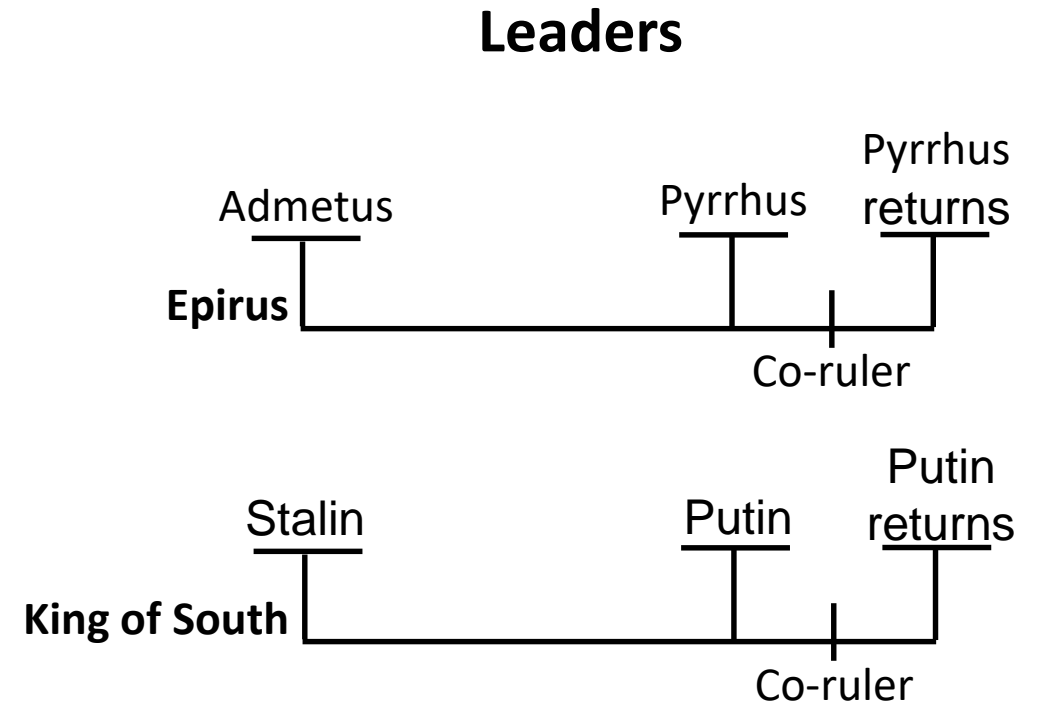

# Histories Combined

So, first of all Acts 27, then the Pyrrhic War, then the Alpha and Omega of the history of Pyrrhus, then the leadership of Epirus, and the King of the South in our day, and then we combined. We cut our line here [between Macedonia and Italy] and we saw Alpha – Macedonia and Omega – Italy, [then cut the line between WW2 and WW3 and we saw] Alpha – World War II and Omega – World War III or our own reform line. These subjects were being studied out in Wales while I was attending the school there in around July 2017.

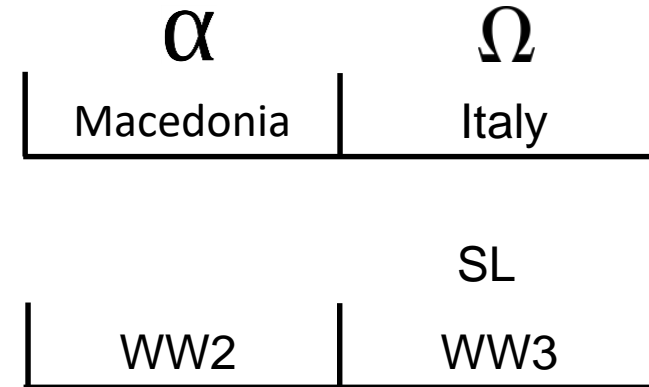

## Combined



## Testimony of Elder Tess and November 9

Soon after I returned from that school in Wales, I went for the first time to Arkansas to the School of the Prophets. Between leaving Wales and the ending of ACE and traveling to Arkansas to the School of the Prophets in the later months of 2017, in ways that I could not explain, November 9 began to be a reoccurring theme through these studies. I believe it was first connected to studying the history of World War II. It was not a subject that I searched for or wanted to delve into but it was an unavoidable reoccurring symbol.

Many of the people watching are aware that November 9 is also my date of birth. Before attending the School of the Prophets in Arkansas that first time in the final months of 2017, I made a request, I asked my mother who was also attending that school for the purpose of teaching at their camp meeting that she not disclose that November 9 was my date of birth. The reason that I was so emphatic that I did not want it disclosed it was not for my own self but that I already believed by October of 2017 that November 9 was a waymark on our reform line and would be a subject of Prophecy, I was afraid that if and when I taught November 9 as a prophetic waymark, my connection through birth with it would be a stumbling block to people accepting it. November 9 is already opening up without human endeavor. In that first school I believe Acts 27 was actually taught, the combination of the lines. This is the only subject where I remember the day.

Through this history I was studying World War II and as I was studying it, I think a couple of people started to refer to the book 'Hitler's Pope' and I became interested on that and my mother bought me that book. Through that story it began to become apparent that there was a great deal of prophetic information that was teaching us about the role of the Papacy in that history of World War II and connected to that it talked about the history of Fatima. As it talked about Fatima, I became interested in the symbols employed in that history. It was November 11, 2017 when Fatima was understood to be placed on a reform line.

# Fatima

Now we have Fatima being introduced, the study of the counterfeit. It was recognized that in this history of Fatima you have a counterfeit reform line with all the waymarks and symbology that we would expect to find on our own line, from the time of the end, to three messages, to a final visible test. And this began the study, not just of the incident of Fatima, but also of the work of the counterfeit.

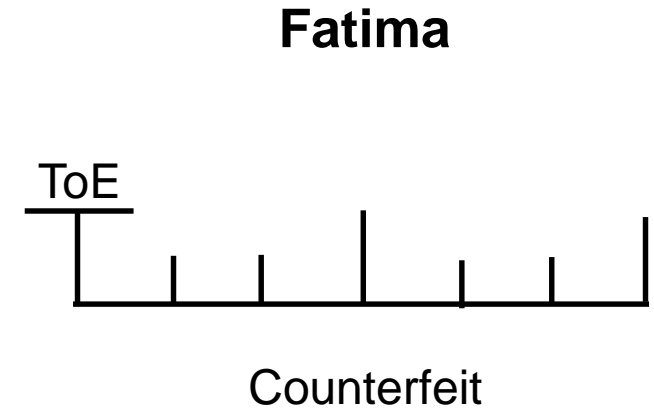

## How Are They fighting?

Putting the counterfeit to one side, World War II is still being studied. As we were studying the history of World War II we see that it connects to 2016 and the question is, “How are they fighting?” We are already at this point in time in the history, I believe this is around January 2018, and the question is asked, “If 2016 is a battle in the beginning of World War II, how were they fighting?”

In every age the war is fought with the materials most recently developed, most up-to-date. The **Stone Age** they fought with **stone weapons**, the **Iron Age** with **iron weapons**, the **Bronze Age** with **bronze weapons**, the **Information Age** with **information weapons**. And now what begins to be understood and studied, is the Information Age and the mode of warfare.



# Information Age

To understand the warfare in our history we construct a reform line and start building a story. We are now in the Information Age. The Big Bang of the Information Age was 1989 and the invention of the World Wide Web. But I want to make a point; I didn't start by teaching this history from 1989. It's story begins in 1969 with the invention of the internet, then you can connect it to 1979, and then 1989 and the Big Bang, as it is so called. 1989 we traced it through 1990 through 1991. Then you could identify in 1996 the first information war, first Cyber-attack between the United States and Russia, also the invention of Google. We could spend all day talking about 1996, then 9/11, 2004, 2012, 2014, and 2016; that is just some of the waymarks we could mark. Already on that reform line we are connecting our waymarks by a thread from 1989, 1990, 1991, 1996, 9/11, 2012, 2014, 2016 we are threading our waymarks. That is how you thread waymarks.

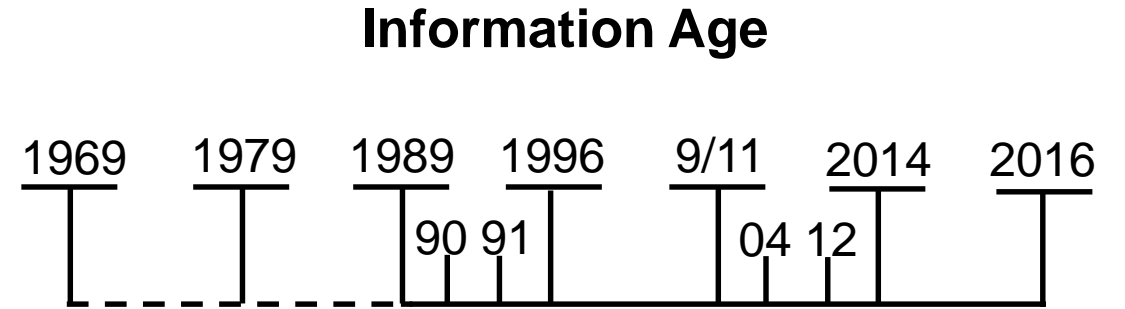

## The Wrong Way To Connect Threads

How you do not connect waymarks is by drawing a line saying 1996 was Hillary Clinton, 2016 was Hillary Clinton, we think she did something wrong in 1996, so we are going to thread waymarks by not considering the Time of the End for any dispensation but beginning it at a formalization starting a thread, thinking that we can skip all of the other waymarks and somehow connect it to 2016. If someone thinks that is how we employ the methodology of building a story and connecting waymarks they have not understood the methodology. I want to spend one moment talking about that attempt. 1996, what has been brought up in Elder Jeff's studies is the Whitewater scandal. Look up a name, David Bossie. In 2016 David Bossie became connected to the Trump campaign.

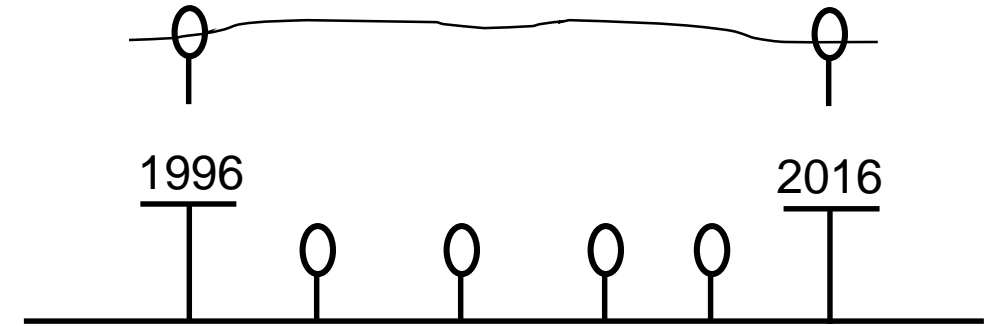

## David Bossie and Conspiracy

I want to quote, *“There's no one in Washington and perhaps the world with a more encyclopedic knowledge of every Clinton scandal and conspiracy theory. Bossie who will serve as Trump's Deputy campaign manager first made a name for himself during Bill Clinton's presidency when he served the Chief Investigator for the House Committee that probed the Whitewater Scandal and numerous other alleged Clinton misdeeds.”*

So, he is a Chief Investigator for the House Committee over the Whitewater scandal. I am quoting now from an interview in November 2018 regarding Donald Trump, he is being interviewed by Chris Wallace of Fox News. Remember David Bossie is intimately involved with the Whitewater scandal. David Bossie says, *“There's a vast left-wing conspiracy that has been going on since Trump won the presidential election all through the transition and during his first two years.”*

A vast left-wing conspiracy are very similar words to what Hillary Clinton called a vast right-wing conspiracy. In 1996 Hillary Clinton is saying there is a vast right-wing conspiracy against her to destroy Bill Clinton's presidency and herself. Chris Wallace, host of Fox News interjected to say that Clinton's claims of a vast right-wing conspiracy in this history did not turn out to be actually true. David Bossie responded by saying, *“No, there was a conspiracy, it was true. Chris, there was an effort by the conservative movement to undermine President Bill Clinton.”* What he just acknowledged is that there is a vast right-wing conspiracy to undermine the Clintons in 1996.

So, if you want to connect threads, this is not an independent thought to what we have already discussed when discussing the Information Age and the work of the vast right-wing conspiracy theory machine that we have already identified as fully up and operational in 2016. So, this is not being ignored; what is being denied is that conspiracy theories are necessarily accurate and what is being denied is that that is how you build a story. You cannot afford to drop threads. And that was the study of the Information Age.

# Information Age & Mode of Warfare

Connected to the study of the Information Age, and the Information Age I would remind us is what we call 'mode of warfare'. You can see the role of the elephants through the histories of Pyrrhus; they decided every battle. Now it's early 2018, the study has since grown and it in itself explains our current shaking, this understanding of an Information War.

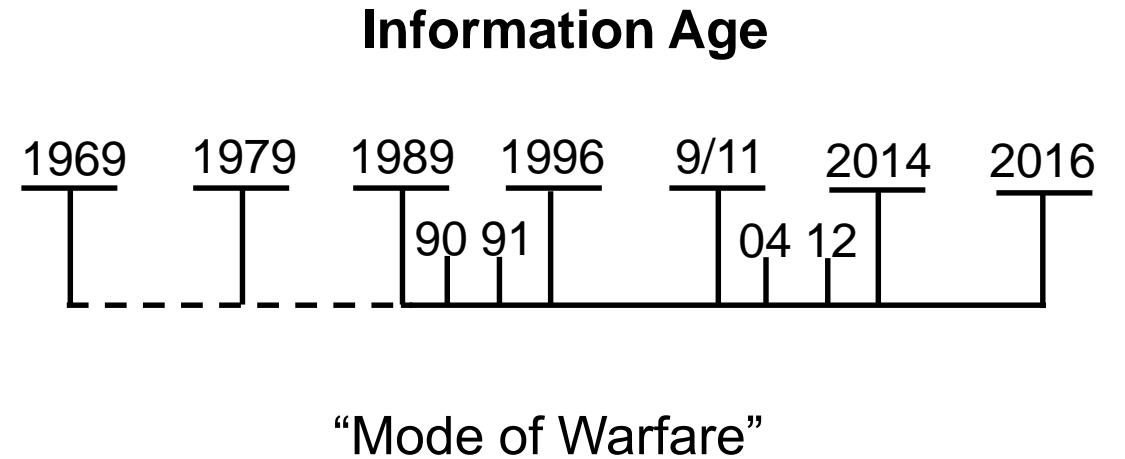

# Parallel Between Internal and External

But what also explains our current shaking is a parallel between the internal and the external in our history. When it is first presented it is more limited in fashion to what we now understand. We have our understanding of the internal and the external. We have identified the work of the external from 2012, the message out of Britain, 2013, 2014, and we connected that to internal, 2012, 2013, and 2014. What I want us to remember, if you have watched the latest studies since October last year, is that this can be developed. Much more information can be added onto this study to show the internal and the external and how that they have related particularly since 2009 to 2019; it is a 10-year history where you can line up the external to explain internal.

## Internal and External

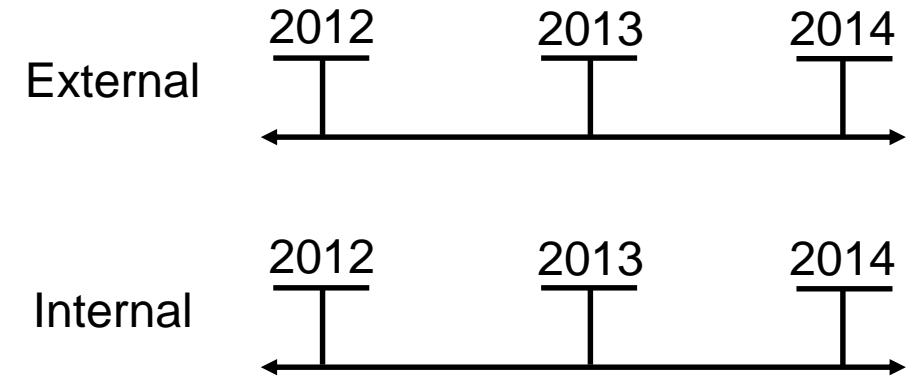

## Parallel Between Internal and External, continued

In 2012 a message comes out of Britain and enters the United States. In 2013 you have the work of enemies against both the leadership and the message; in 2014 all of that begins to be operational. 2014 the waymark for this movement, we will not go into further detail or we will spend all day. 2014 externally, the work of Cambridge Analytica. Through that history 2012, 2013, 2014 we are not just lining up events, but people; we are lining up a leadership that is going to, through this swelling of a movement under Donald Trump, take the United States all the way to the end. In 2012, 2013, 2014, you have Donald Trump relatively in the shadows but it's building. Internally, Elder Parminder bringing a message from Britain and you have that swelling internally; there is already a new leadership but it takes time. In 2015 Trump announces his candidacy and begins campaigning; in 2015 Elder Parminder begins teaching. In 2016 Trump is elected; in 2016 Elder Parminder is anointed. In 2018 is the formalization of this message but 2018 is the Battle of Heraclea. You can line them up.

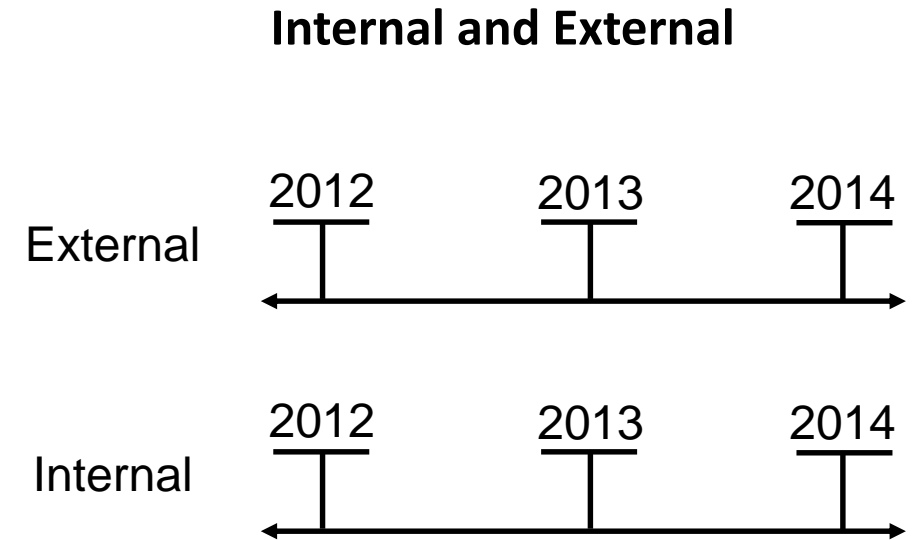

## Parallel Between Internal and External, continued

Just one point, in 2019 who just began to be impeached? Externally you have the impeachment of Donald Trump; his leadership is now under attack. Internally you have the leadership of this movement and an attempted impeachment.

Question: Which side wins externally? Donald Trump is the last President of the United States; we know he takes them all the way to the end. So, internally who wins? Obama might not like it but there is a new leadership. Trump will not be removed from office, neither will Elder Parminder be removed from the leadership in this movement despite the work of enemies. Paralleled, internal and external.

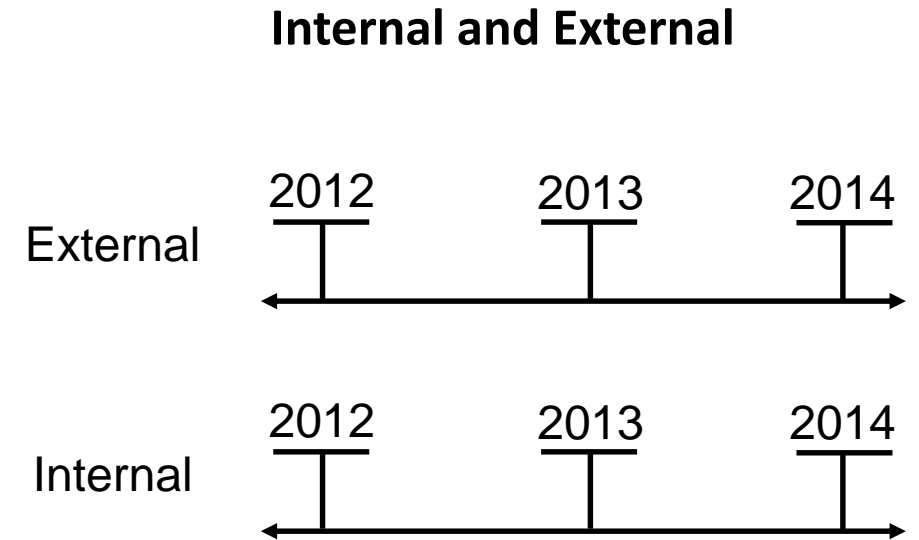

# The Pattern of the 10

The next study. All through this time November 9 has been a subject that could not be avoided. I did attempt to avoid but it would continue to come up through our studies and particularly through studying the history of Fatima and the counterfeit and World War II. Now it is not just November 9 that is beginning to open up but also the year 2019 itself. And the first pattern or cycle that begins to open up in relation to this is the 10-year cycle; observing that in our history beginning in 1789 you can mark a pattern of 10-years that would take us to 2019 as being a significant year. That was the pattern of the 10.

## The 10

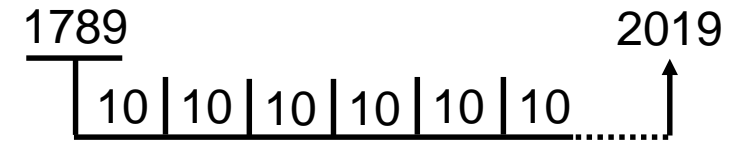



# 2019

When this subject in 2019 began to open up I began looking at the French Revolution and observed that in 1799, again it connects to the pattern of the 10, there was the rise of Napoleon. And it drew my attention that he becomes a dictator in 1799 but also on November 9. Now the two studies are connecting, the study into 2019 and this repeating November 9 story; they connect. And now an intelligence study begins into November 9, 2019. And all of these histories that take us to 2019 begin to open up. We go back to 1529, this is the Protest of the Princes. I will not go through all those dates but you have the Protest of the Princes, the restraint of radical Islam, a dictatorship in Napoleon, an impeachment, the first impeachment in US history, you have the coming together of church and state, an uncovering of the work of Stalin, the beginning of open persecution, the Night of Broken Glass. All of those subjects begin to open up and while not yet officially and publicly taught, I think many of you can see them under fulfillment.

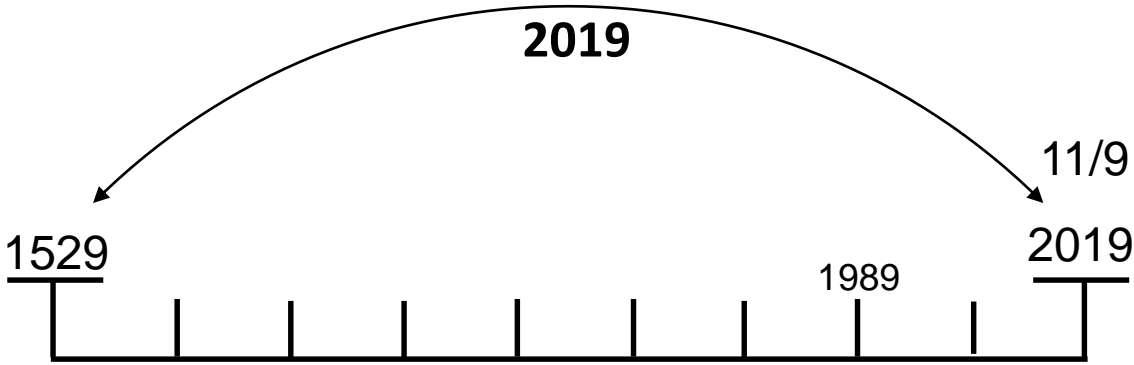

- 1529 Protest of Princes & Restraint of Islam
- 1799 Napoleon's Dictatorship
- 1868, 1974, 1998 Impeachment
- 1893 Church & State – Chicago World Fair
- 1938 Persecution – Kristallnacht
- 1956 Uncovering Stalin

## 2019, continued

This is 2019 opening up and showing to us not just the year but also the evidence for the day. This is all in the early months of 2018. Around the time of May 2018 there was a school held in Australia, Elder Parminder was our teacher and this gave us a real opportunity to sit down and discuss what I had been studying. In these studies, we took the time to review all of these different lines that we're opening up. But at this point in time while I identified 2019 as a waymark, I did not know exactly what that waymark was supposed to represent. So, I attributed to 2019 the same understanding that had been swelling in the movement, this concept of a Prediction Before Midnight (PBM) and it was my understanding that 2019 must be PBM because that's what all I had heard people discuss.

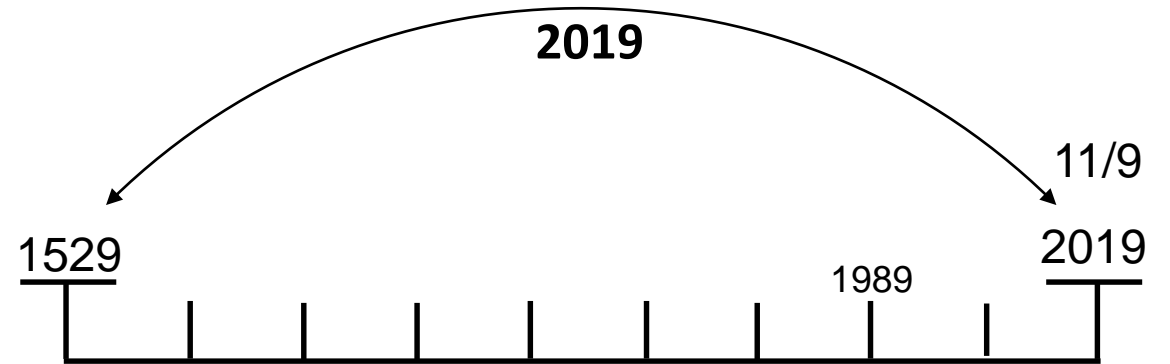

- 1529 Protest of Princes & Restraint of Islam
- 1799 Napoleon's Dictatorship
- 1868, 1974, 1998 Impeachment
- 1893 Church & State – Chicago World Fair
- 1938 Persecution – Kristallnacht
- 1956 Uncovering Stalin