

The book of Daniel begins during the reign of Jehoiakim (Daniel 1:1). The story goes all the way “Dan 1:21: And Daniel continued even unto the first year of king Cyrus. “

We could place Daniel between the 1st year of the king Jehoiakim to the 1st year of the king Cyrus.

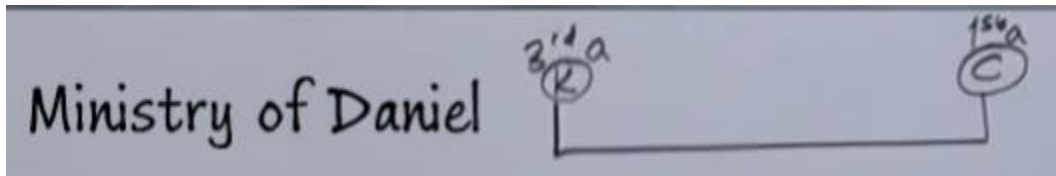

In Dan 10:1 it talks about the 3rd year of the king Cyrus. We want to understand the relationship between the Dan1:21 the first year of king Cyrus and the 3rd year in Dan 10:1.

I will demonstrate that the 1st year of Cyrus and the 3rd year of Cyrus is exactly the same point in time.

We spoke about Jehoiakim and mentioned that from Jehoiakim to Cyrus is 70 years:

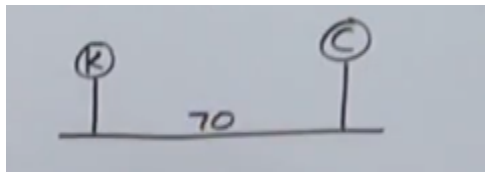

But you know that Babylon fell (Dan 5:31) during the reign of Darius the Mede. Ch.6 speaks about the events occurring during the reign of Darius. We will place the fall of Babylon during the reign of Darius.

Ellen White teaches us that Darius reign for 2 years. There is this 2 years:

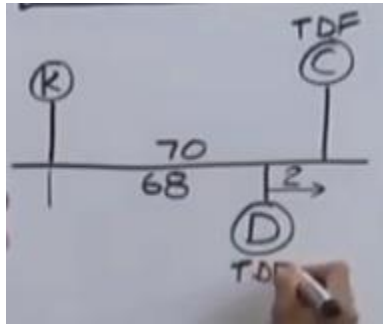

If this is 70 years, we know that this is 68 years. If you follow the logic presented earlier that the 70-y captivity was symbolically the same as 1260. At the end of the 1260 is the Time of the End, this is where Babylon or Rome receives the deadly wound when the nation of France brings the pope off of his throne and cuts all ties with the papacy. We know that the end of 1260 marks the ToE indicating that the end of the 70 y. would **also** mark the ToE. We will mark Cyrus here as at the ToE. But what we can see

in the line of 1260 is that when Babylon (Papacy) receives the deadly wound this marks the time of the end. So, the 1st year of Darius will also mark the ToE. So, you have an apparent problem: you have two waymarks, both representing the ToE. This is not that unusual: when we look at the 9th month and the 1st month for example; you can take various symbols, different events which are separate and combine them. We marked in the 9th month when the rain happens and they are separating from the strange wives. So the 9th month marks the separation from the strange wives. By the end of the chapter, that work is completed by the 1d1mo. And here is the 1d1mo:

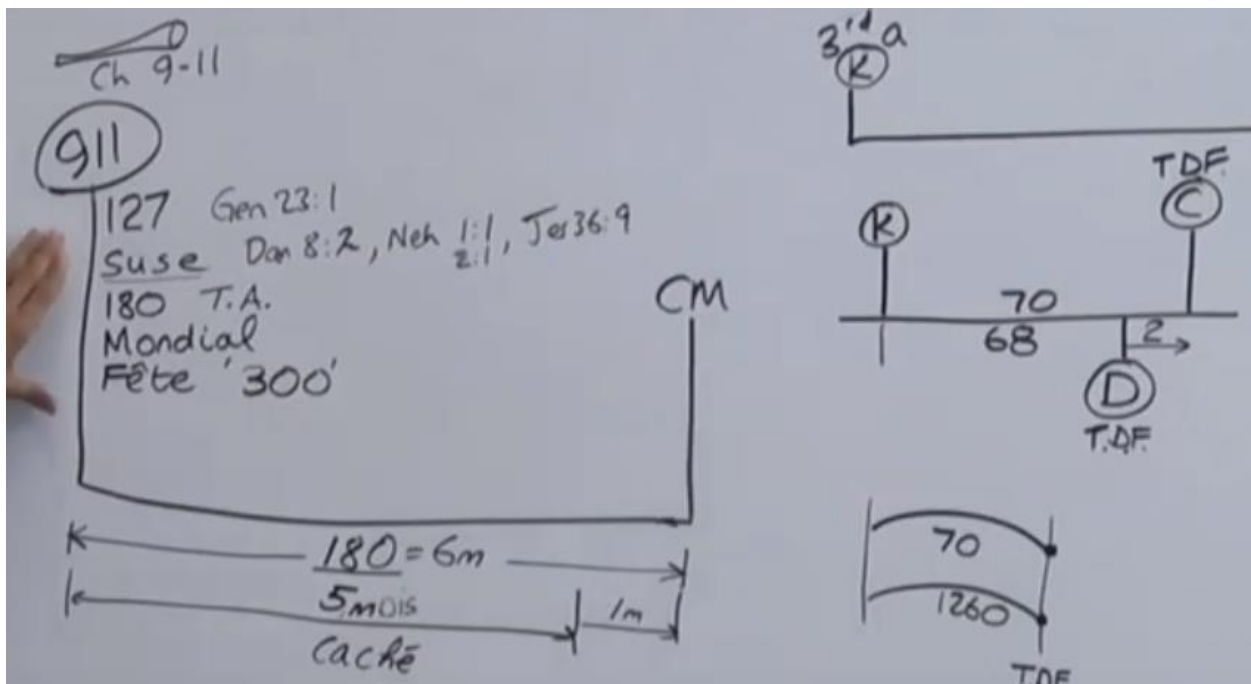

So the 9th mo. and the 1st mo. are brought to view in Ezra 10 and Nehemiah ch.1 and 2. Both of those individual dates line up one with the other. That is all we do in here, take two individual dates with two separate kings and combine them:

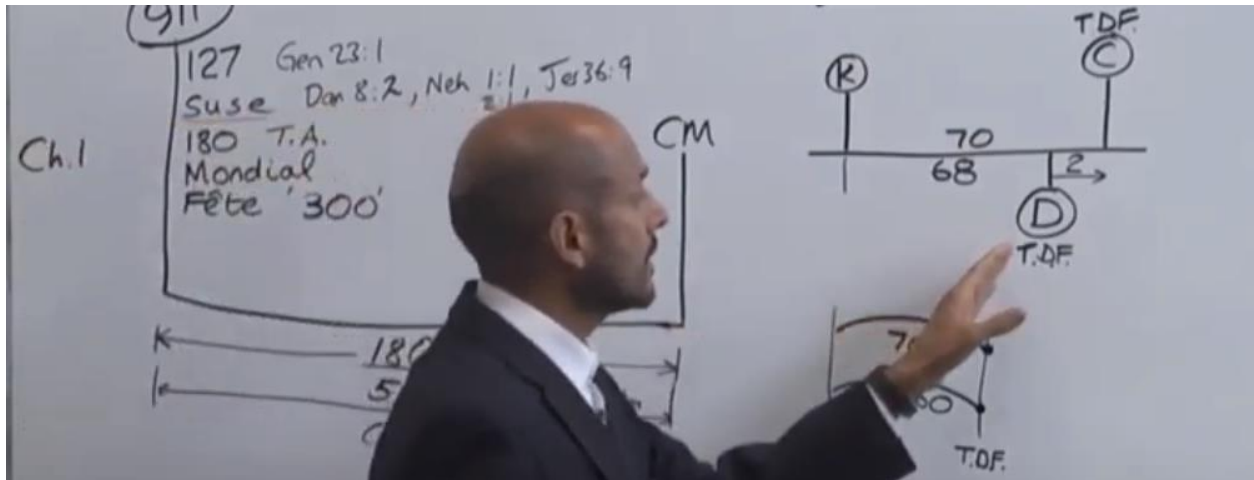

In Dan 1 it is the 1st year of Cyrus but in Dan 10 it is the 3rd year Cyrus. Let us reconcile those two together. For this you need to know a little bit of historical background about Cyrus. He, first, rises to the throne of Persia at 536 BC, and this 538 is the 538 in the 1840 chart:

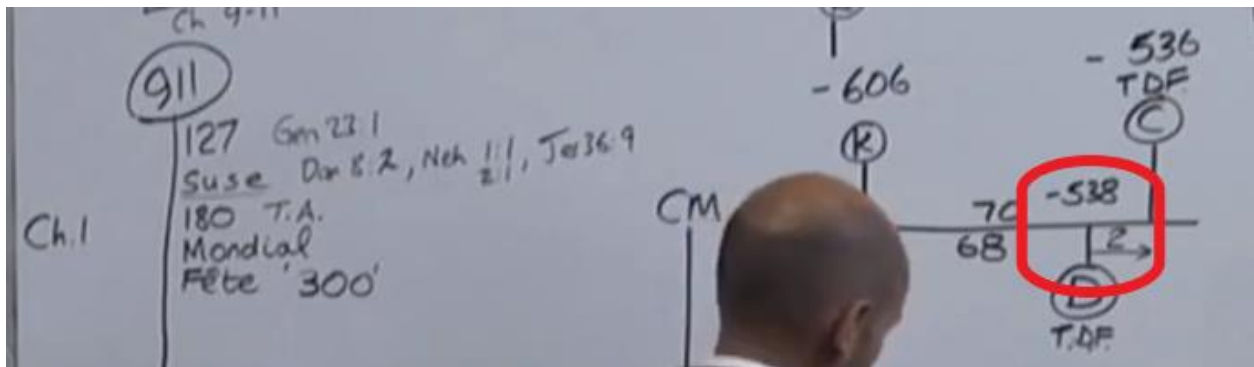

<p>B A B Y L O N .</p> <p>MEDIA AND</p>	<p>677</p> <p>Commencement of the seven times. Leviticus 26:20 to 24.</p>	<p>2520</p> <p>7 times.</p>	<p>12</p> <p>Months.</p>
	<p>538</p> <p>Overthrow of ancient Babylon. Daniel 5:1-31.</p>	<p>677</p> <p>2 Chron. 33:11.</p>	<p>84</p> <p>Months.</p>
	<p>457</p> <p>Going forth of the decree to restore and build Jerusalem. Ezra 7:8.</p>	<p>1843.</p> <p>Termination of 7 times.</p>	<p>30</p> <p>Days denote year.</p>
	<p>1843.</p> <p>Termination of 2300 days, and end of Indignation Dan. 8:17 to.</p>	<p>2300</p> <p>7 times.</p>	<p>2520.</p> <p>7 times.</p>

So, the 538 is the fall of Babylon.

So, Cyrus is a king of Persia in the year 539, then he becomes king of the Median Empire in 549, and then a of Lydia in 547, and Babylon in 538:

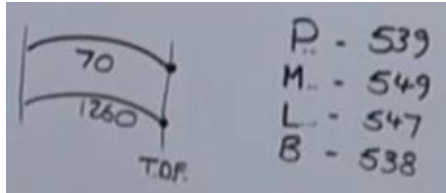

You may have noticed a slight problem: we read in Dan 5 and 6 and 9 that the king in Babylon is Darius the Mede. That is why we marked the 1st year of Darius the Mede. But I am suggesting that Cyrus was the king of Babylon in 538. I am not the only to suggest that. Many secular historians

don't even recognize Darius the Mede as being a king. Cyrus is recognized as the king. So, the Medes and the Persians are two dynasties that comes together through intermarriage and Cyrus is already the king of Persia, then he becomes the king of the Median empire 10 years before he enters the Babylon. He is the general that masterminds the collapse of the Babylonian empire. When he brings that Babylon to its end in 538, you know that because there is a prophecy about him doing so that he hands over the reign to his uncle Darius, but the real king is Cyrus. Today we would call him a puppet king, but Cyrus is an honest and straightforward man and not controlling and manipulating his uncle. That is why we will mark the 538, 1st year Darius as the 1st year of Cyrus (which is in agreement with the secular history), 537 = 2nd year and 536 = 3rd year if you consider that his reign actually starts at 538 and also his 1st year as a sole king:

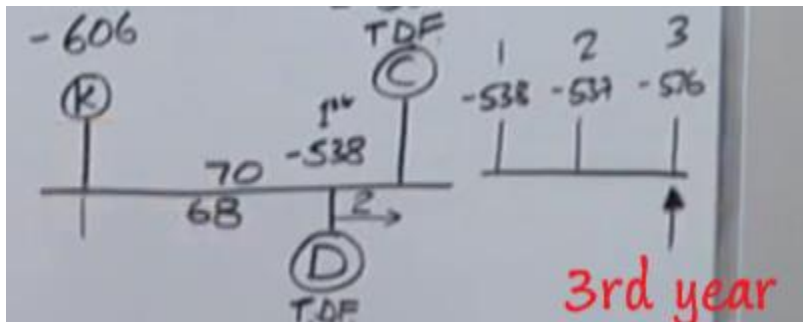

This explains the discrepancy between the Dan 1 and Dan 10. They both (538 BC and 536 BC) represent time of the end.

So at 538, I am suggesting we have two kings: Darius the Mede and Cyrus:

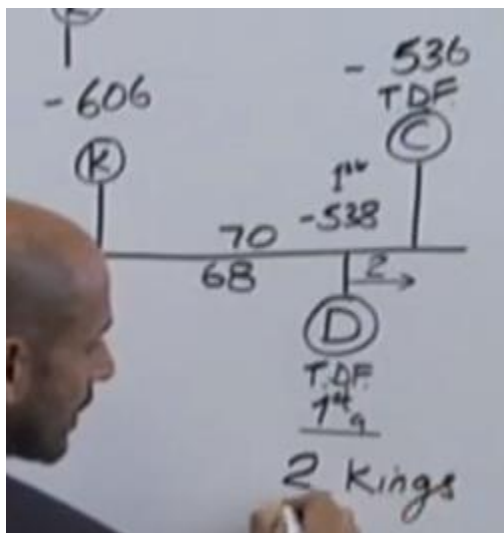

In Rev 16 (end time scenario) the imagery used (as in most of the Revelation) is of old testament stories:

[12 And the sixth angel poured out his vial upon the great river Euphrates; and the water thereof was dried up...](#)

If you go back to the history that we are dealing with here, you know that river Euphrates is literally dried up. So, when it is talking about the great river Euphrates drying up, it is talking about this story when Cyrus diverting the flow of the river. Babylon was built on the river Euphrates:

Below is the river Euphrates passing through Babylon.

There were many bridges that span the river. There is a great floodplain in the area below that when Euphrates breaks its banks the water would not flood the city. Cyrus built channels or

canals, kept barriers there, and at certain moment he broke the walls and all the water flowed out and dried up the river Euphrates.

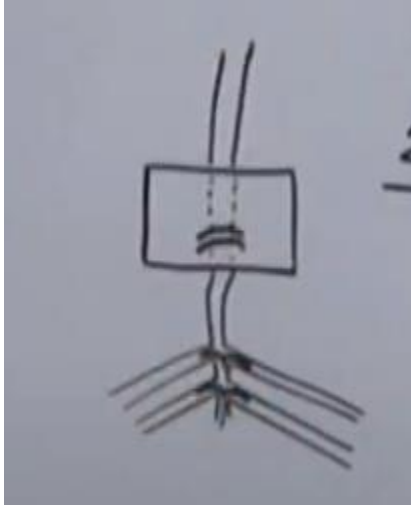

Then they were able to march down the riverbed of Euphrates, and there were large gates that blocked the entrance into the city, but through negligence the gates were left open and they marched in and destroyed the city. The book of Isaiah explains all of this.

[that the way of the kings of the east might be prepared.](#)

It says the river Euphrates dried up so that the road for the kings of the East might be prepared. "Kings" is plural and we know that at this time Darius and Cyrus were there, and they were both kings. Cyrus is the real king; his uncle Darius is like a figurehead to maintain stability. We can see that the reason to

make both these dates (536BC and 538BC) as ToE by understanding that Cyrus is the king at both points not only fits the historical structure of this passage, not only agrees with the prophetic fulfillment of the 1260 and the deadly wound but is in agreement with the Revelation 16:12 when it talks about **the kings of the East**.

We established that Dan 10:1 is the 3rd year, Daniel has conversation with Gabriel and in ch11:1 Gabriel explains to Daniel something, but before verse 1 he is in a conversation with him and he says I have been struggling with the powers of Satan who he identifies as the prince of Persia. This symbolic prince is Satan who is trying to keep control of the Persian empire through the mind of Cyrus because here (536 BC) Cyrus is going to release Israelites from captivity because we are at the end of the year 70. Satan doesn't want this to happen and tries to influence Cyrus' mind. That is what Gabriel is talking about. Gabriel tells that he is not able to beat Satan, so Michael helps him. Michael is a symbol of Christ. The he (Gabriel) says that once this is completed, I am going to do the same with the prince of Grecia, showing that struggle will continue after the king Persia comes off the scene.

Ch11:1 Also I in the first year of Darius the Mede, even I, stood to confirm and to strengthen him.

So the speaking is happening here in 536BC, but he is speaking about an event that happened two years before at 538BC, because we identified it to be the 1st year of Darius. In Daniel chapter 6 when he gets into problem with the king because he is praying this is happening in the 1st year of Darius. If you go to Daniel 9, that is also the 1st year of Darius. So, the prayer that Daniel is doing in Dan 6 (anybody who prays to a god other than Darius would be punished) is the prayer of Dan 9. So the long repentant prayer in chapter 9 is the prayer mentioned in Dan 6. Satan does not want Daniel to be the 1st prince influencing the mind of Darius in the right direction he wants to stop this from happening and influences the mind of Darius right here (at 538 BC) and that is what Gabriel is doing. He says: "as Satan wanted to influence the Darius'

mind here at 538BC, and he wasn't able to, because I strengthened the Darius' mind. So now I am doing here at 536 BC with the Cyrus"

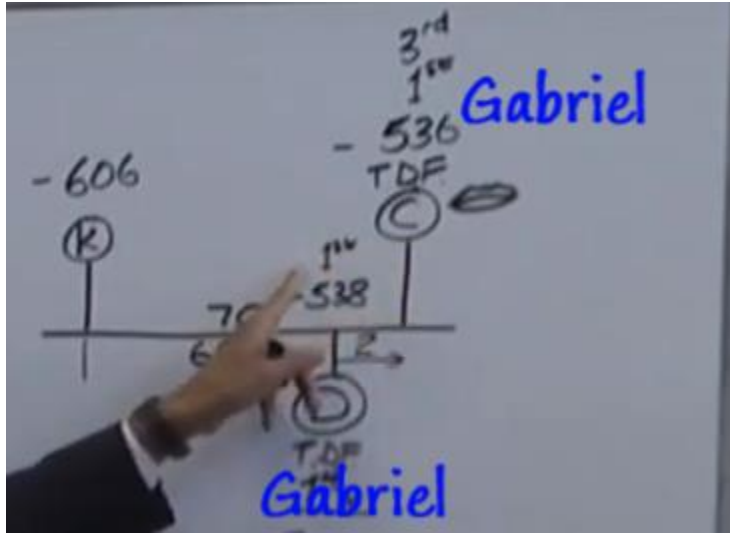

So, Gabriel becomes a common symbol at these two waymarks. The thing that is making it common is: 1st year of the king, ToE and Gabriel strengthening or confirming. So we have multiple symbols identifying that these two waymarks are the same event, even though historically they are two separate years.

When you are doing your own prophetic study, you need to be able to divide the word of God in this fashion. To not being constrained with the

things happening at the different times because they may represent the same event. So, at the time of the end we have all these three things happening: 1st king, ToE, Gabriel.

In Millerite history the time of the end was 1798. This is Dan 11:40. We can line this up with 1989 in our history. This

In Dan 11:2 this conversation is happening in the 3rd year of Cyrus (Dan10:1). The 3rd year of Cyrus is also the 1st y of Cyrus, the end of the 70 years, and therefore it is the time of the end, and Gabriel is strengthening the king. These 3 waymarks are the exact same waymarks as the 1st year of Darius which is Dan 11:1 (in the 1st y of Darius when the Babylon fell Gabriel strengthened Darius, but now in vs 2 we are still in the 3rd year of Cyrus:

And now will I shew thee the truth. Behold, there shall stand up yet three kings in Persia; and the fourth shall be far richer than they all: and by his strength through his riches he shall stir up all against the realm of Grecia.

In our last presentation we mentioned the last part of this verse, and we spoke about "through his strength...", he rules over 127 provinces, he is the richest of all the Persian kings, and he is going to stir up and collect these 127 provinces for the war against Greece. He will persuade them that his project is the right way to go. All these is happening from 9/11 and onwards to Midnight Cry.

"Behold, there shall stand up yet three kings in Persia" – In plain English that means after **THIS** there is going to stand up 3 kings. Therefore, we need to understand "**THIS**"

It says: "... yet three kings in Persia..." There shall stand up yet... that means AFTER THIS. So that this is Cyrus. And we are at the time of the end. So, the conversation in the present time period is the Cyrus. Then it says there is going to be 3 more Persian kings.

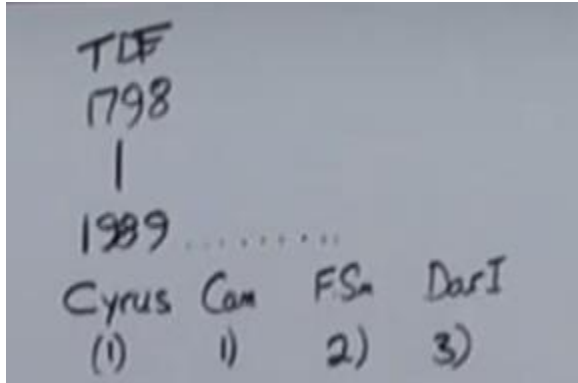

- 1st = Cyrus,
- 2nd = Cambyses
- 3rd = False Smerdis
- 4th = Darius

This Darius is the father of Ahasuerus. He tries to take Greece captive utterly failed because he didn't make proper preparations. His son is going

to sort the problem out. He will finish off what his father was going to do. He is going to assemble the biggest army the world has ever seen up to this date and this 6 months of feasting is preparation.

Behold, there shall stand up yet three kings in Persia; and the fourth shall be far richer than they all

The 4th one after Cyrus (1= Cambyses, 2 = False Smerdis, 3 = Darius, and 4th = Xerxes) is Ahasuerus. Or Xerxes:

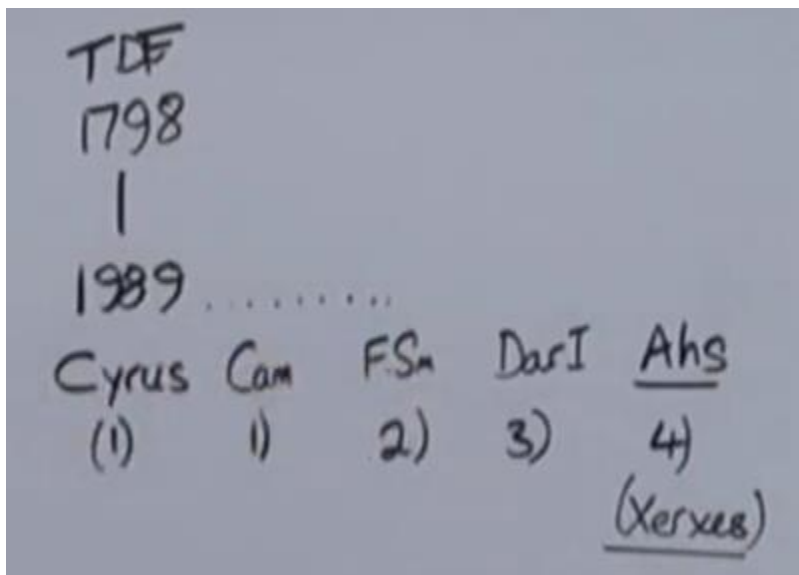
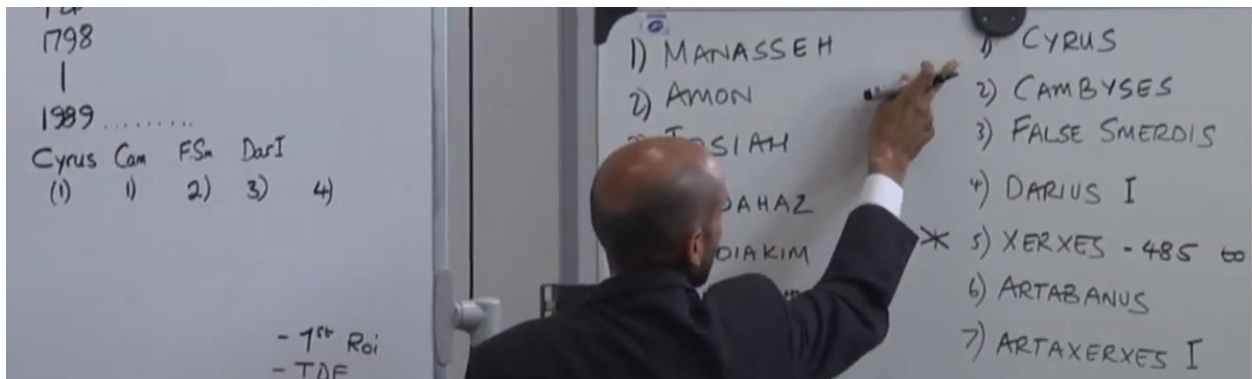

We have read what he does his abilities: richer, stronger.

We need to be able to see is that symbolically Cyrus represents 1989, and then you have these 4 kings that follow. It is not necessary that these kings would line up with specific waymarks after the time of the end. I am not looking to do this:

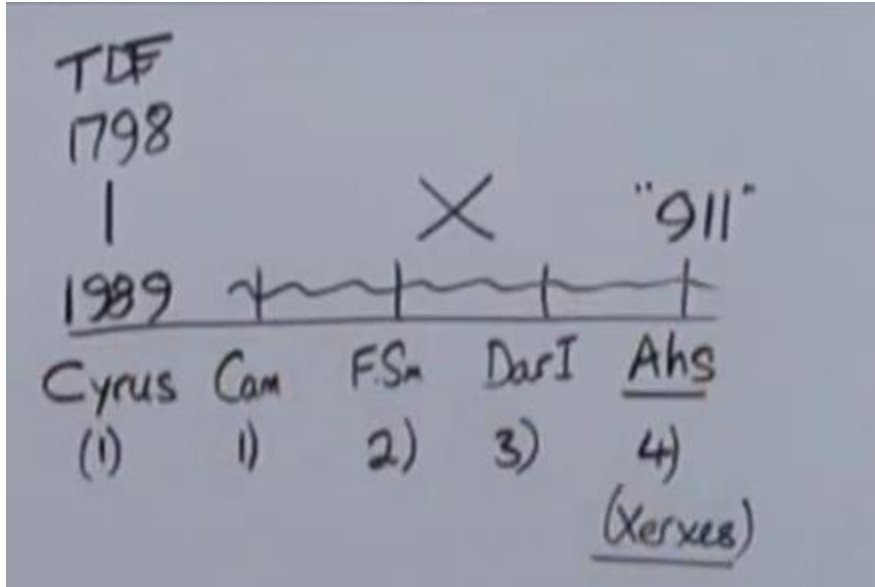

This is **NOT** the way we need to understand that.

We know that this 4th king Ahasuerus is in the book of Esther and we have already marked the book of Esther as beginning at 9/11 where he (Cyrus) is doing these war meetings. So you know Ahasuerus is "911" just from the book of Esther.

We are not lining up any

of these individuals.

These kings/kingdoms represent symbols: gold, silver, brass and iron.

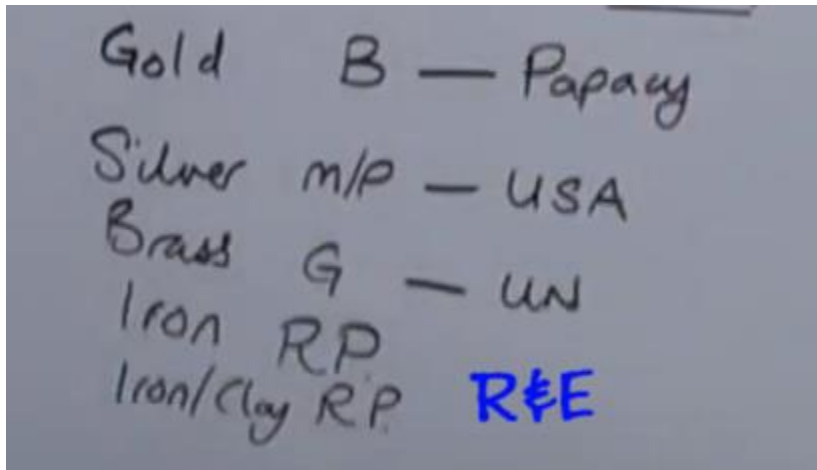

I want to show that this Babylonian head is a representation of the Papacy. And the Medo Persian Empire = symbol of the U.S. The Greece is the symbol of the UN. The legs/feet – are the Repeat and enlarge of the truths that have brought here.

We want to concentrate at this moment is that the Medes

and Persians are a representation of the U.S. You and I should know that the U.S. in the Revelation 13 is represented as a beast with two horns and those 2 horns can represent:

- a. Economic and Military strength as in Dan 11:41
- b. Protestantism and Republicanism (traditionally)

Horns are normally a symbol of strength. What makes this beast strong is the separation of the church and state. We know that the U.S is a symbol of something that is composed of two elements, two horns or two strength.

You also know that the empire of the Medes and Persians is also a two horned power, it's an empire that consists of two parts. If you go to any symbol that is composed of two elements you will see that that can be a symbol of the United States. Some examples of these would be France (in the past) from Revelation 11, two horned power – Sodom and Egypt, Medes and the

Persians, when Israel is split into North and South – Judah and Benjamin, Egypt – it is also a two horned power: Upper Egypt and Lower Egypt, so any time you see in the Scriptures any of these nations you know that if you make the right application with the right setting, they can all represent at some level the United States. It is all based upon the principle that the United States is a two horned power. In the story of Egypt it can represent the world at one level but also United States at another level. Some people will think that this is a contradiction, because if you are familiar with Dan 11:40-45 the U.S. there is identified as the glorious land, and Egypt as the world. The world is not the U.S. but when you see the sequence of events occurring that you can show that this Egyptian symbology at verse 42 is at some level the US. Because the US is a part of the world, but also a superpower, the most powerful nation, so it is not incorrect, even in Dan 11:40-45 to have two separate symbols representing the work of the U.S. in two separate phases. Because after verse 41 when the U.S. dies at one level, but it will still be alive, especially the way is portrayed figuratively in the prophecy as world.

We are looked at the Medes and Persians as the U.S.A. We start with these kings beginning at 1989 based upon the study of Dan 10 and 11. This empire is the symbol of the U.S. If we were to look at modern events, and if we were to see how this Medo-Persian empire is portraying the events at the end of the world. If mark out the leaders of the U.S. we will come to an interesting conclusion: in 1980-s Ronald Raegan went into the secret alliance with the Papacy John Paul II for the purpose of bringing down the Soviet Union. That event occurred in the year 1989 and Ronald Raegan wasn't the president at that time, it was someone else. What you need to know about the presidential elections is that they have elections on an even years (not odd numbers) but the incoming president doesn't take his office until the following year – odd year. Presidential elections occurred in the year 1988 in November but took seat on 1989 in January.

So, this time lag is a time period to hand off the office. So presidential elections are carried out on even years and taking office on odd years. Next year, 2017 will be when the new president takes his office.

So, in 1989 the new president was George W Bush. When he become president one of his famous speeches was there is the new world order coming (he referred to it as already in place). This is the year that we mark as the fall of the Soviet Union – that mark is the fall of the Berlin wall. We often associate Ronal Raegan with that work, but he was not the president when it happened, it was GHW Bush.

The next president was W. Clinton. The presidential election was at the year 2000 but the switchover completes at 2001.

The next president is GW Bush – the son of the previous Bush, then Obama. An the incoming president will be serving from 2017 onward either 4 or 8 years.

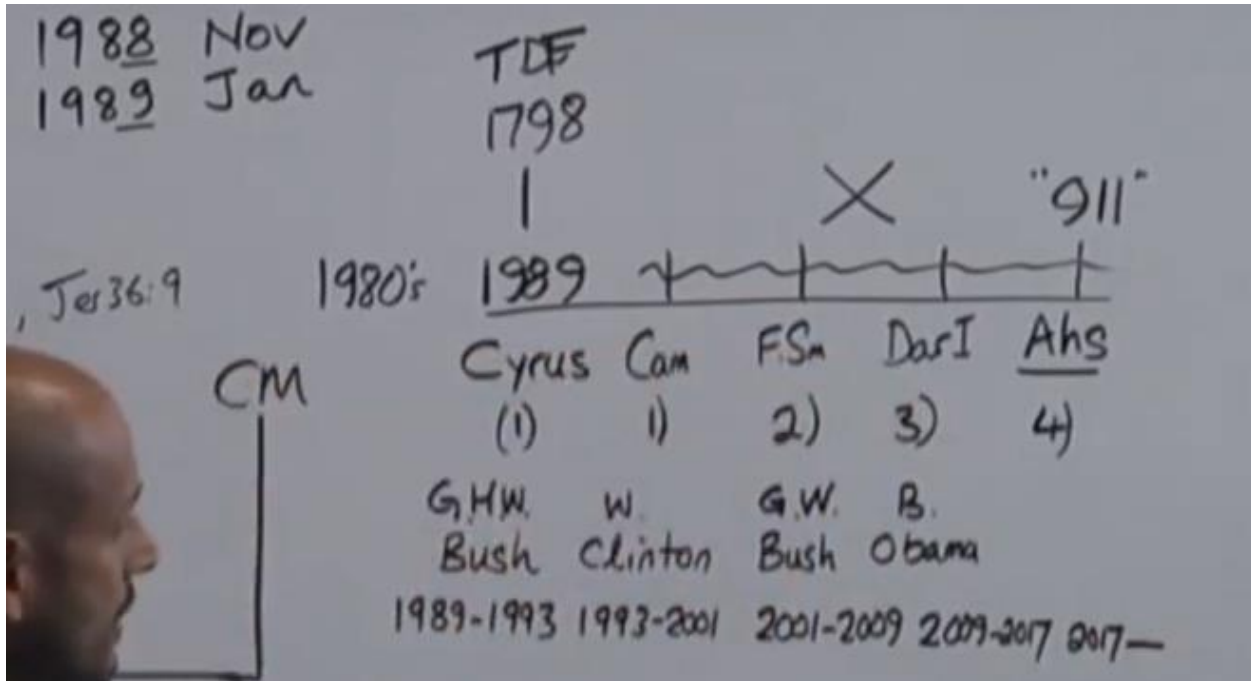

We can begin to line up the reign of these kings with the presidency of these leaders of the U.S. There are interesting things about these presidents, especially GW Bush. Cyrus has two sons: Cambyses and Smerdis. When Cyrus dies, Cambyses comes to the throne and the first thing he wants to do is to sort out his brother, and he gets rid of Smerdis. If you have studied history, you might be familiar with the stone age, bronze age, cave men, etc. This is the iron age. This is not modern history, this is 1000s of years ago. They don't have the technology like we have. Most people like you and I, can go on the news and find out how the president looks like, their height and weight, but 1000s of years ago normal person does not have access to the king, and does not know how he looks like. He would be lucky if he see the king's carriage. So you can go your whole life and never even know what your king looks like. Smerdis is killed but Cambyses dies and then there is this usurper to the throne comes – False Smerdis. He is false is because he pretends to be Smerdis as he can get away with this pretense because nobody knows what the real one looks like. He comes back after the death Cambyses and says I didn't really get killed, I was only wounded, and been in hiding all these years, and now I've come back to get my rightful throne. Who would know the difference? This False Smerdis is a usurper, who comes to the throne through lies and deception, not the proper way. This presidential election (GWBush) was one of the most controversial elections in the history except of one other. In the U.S. it is funny. You would think that if you had 100 people in the country and 51 votes for one and 49 for another, the 51 vote will win, but that is not how it works in America, they don't care for the peoples votes, their system is based on college voting system: not the peoples votes, but politicians votes. That is what happened. The person's name was Al Gore. Bush lost the popular vote by half a million votes. But when they counted the votes of the politicians it turned out that Bush won. Then they recounted the votes in Florida, and they realized they made a mistake, this went right to the Supreme court and they said it was illegal to recount the

votes in Florida. So the original vote count stood and in real life he got 277 politicians votes and Al Gore 266. And he did some illegal things in Florida to make sure that he would win. So Smerdis is the son of Cyrus and GW Bush the 3rd president is the son of GHW Bush, but in this (MEdo-Persian) history he is the false, usurper son. So, it is not a coincidence that the 3rd president is the son of the previous president, and he was a usurper. Also remember that 9/11 is in 2001 and marks GWBush as a usurper.

Previously I have connected the 9/11 with the 1888 history as the arrival and empowerment of the 3rd Angel.

The other most controversial presidential election where this flip happenend when people vote one way and electoral college vote another way was in the year 1888, which is the 2nd witness that this structure is correct. GW Bush, the usurper is the son of Cyrus – GHW Bush, is occurring in the year 2001, 9/11, the controversial presidential election all line up with 1888.

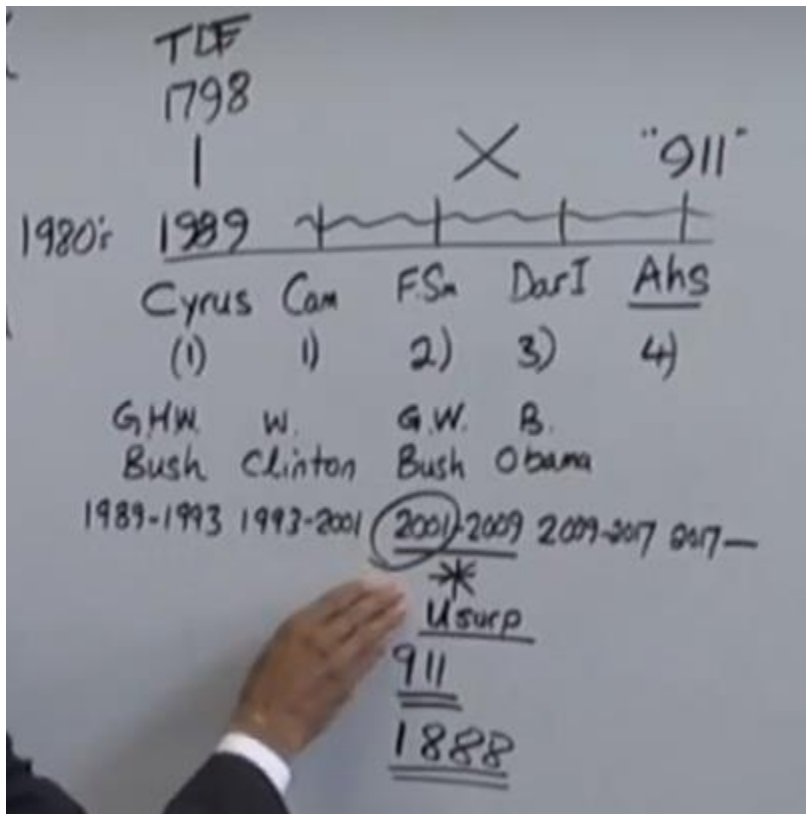

Darius I – Barack Obama. The single most failure of President Barack Obama is the following:

It is not a real failure. He was on a systematic, one of the most powerful presidents that ahs ever presided over the U.S. Before your very eyes in the last 8 years he totally reengineered the role of the U.S. in the world. The U.S. used to be the de facto superpower in the world (Ronald Raegan in part saw to that). But in one presidency B. Obama has turned the U.S from the

world's most powerful nations on this Earth to a country that is weakened: no longer have a leading role on the political stage. The enemies beat them. They do deals with nations and lose money. You might think that this is all accidental that we are dealing with incompetent leadership in the US, but it is not correct. Denesh D'Souza made it his business to analyze the presidency of Barack Obama and when people criticize Obama (i.e. he is some undercover Muslim, doesn't like Christians, incompetent,) he come to a different conclusion, Obama is a Christian, not Muslim, no affiliation to Islam, all these are misunderstanding. The US is the army of Rome (Christian), not the friends of radical Islam. Neither is the president. But he has a directed plan to make the US just another nation in the world, because he has this belief in equality. This is the simplest way I can explain, but if you look up Denesh d'Souza he has got a lot of information to substantiate what he is saying. So, the weakening of the U.S. and its "failure" to take control of the world and be the controlling influence is something that has occurred during the presidency of Obama. Nobody can understand how all of these countries Iran, Russia, Iraq, Syria, why he doesn't take a grip and control to sort it out. Remember what we said about Darius I. What was his mission? – to bring down Greece, at the end of the world Greece = UN, UN = world. Darius failed to take control or subjugate Greece, Obama failed to take control and lead the world today. You can see that these men in their presidencies are fulfilling the roles of these Medo-Persian kings.

We have seen that Cyrus, the double king marks the ToE, his son is usurper, Darius fails to take control of Greece, symbol of the world. Then follows a man who is far richer of them all who is going to sort out all of this mess. This man is symbolized here (he is not the president at 911, but it is symbolized in the book of Esther as occurring at 911, this is not in opposition with the fulfillment of prophecy):

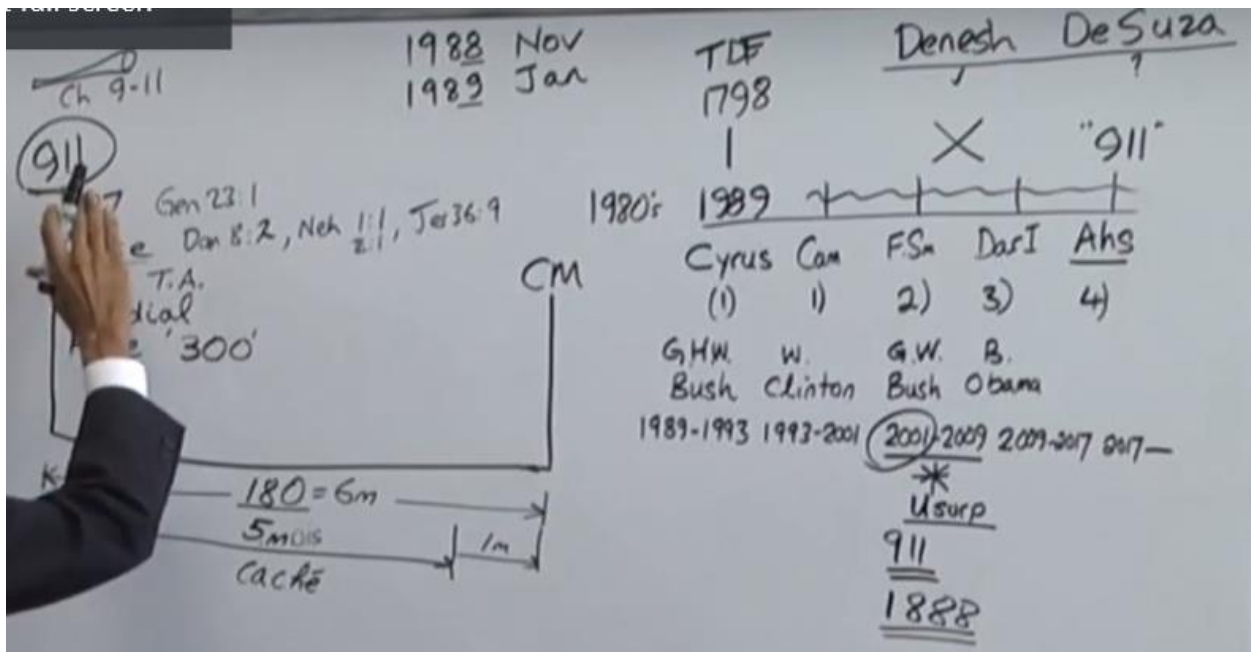

The sole purpose of this 6-month feast was to prepare for war against Greece. He is going to undo the failure of this man (Darius, Obama). The presidential election going on now is one of the most fiercely fought for. It is not unusual, in fact, it is beautiful that his running mate is a woman. That is a phenomenal new thing. What make it so unusual is the man she is running up against – Donald trump. He is an interesting man. People think that he is a comedian. Has no political training it would appear. Seems that he has come out of nowhere, but if you go on the internet he has been in the public eye for a long time. And in the political eye. He has made it his business to be in the public eye and be friends with the politicians. He doesn't hide that fact. If you see interviews of this man 10-15-20-25 years back one thing consistent is that he has had ambitions to be a leader for a long time. People would ask him "Have been interested in being the president of the U.S.?" he would be coy, would joke about it, say no but have a smile on his face. You know that this man had an eye for this job for a long time. He did try to become president a couple of presidential elections ago, but it didn't work, he approached the wrong way. He has been waiting to approach it in a proper way, and against all odds, he is now the front runner for the Republican part. Is this man going to be the next president, will he fulfill the role of Ahasuerus, the man that is far richer than all of these men before him? He is the only president (at that time) who self-financed his campaign and makes a great play on this, that he is not anybody's puppet or a yes-man, because no one can control him. He hasn't been elected yet and already stirred up the whole world against him. There is no country that is not troubled by imminent presidency. Ask yourselves, is prophecy is being fulfilled when we consider this man. The reason is if you can see light in this, then we know that prophecy is being fulfilled, we are in this time period (between 9/11 and Midnight Cry) and the book of Esther is being fulfilled. Saying that, we are not placing Trump at 9/11. This is a structure – 180 days:

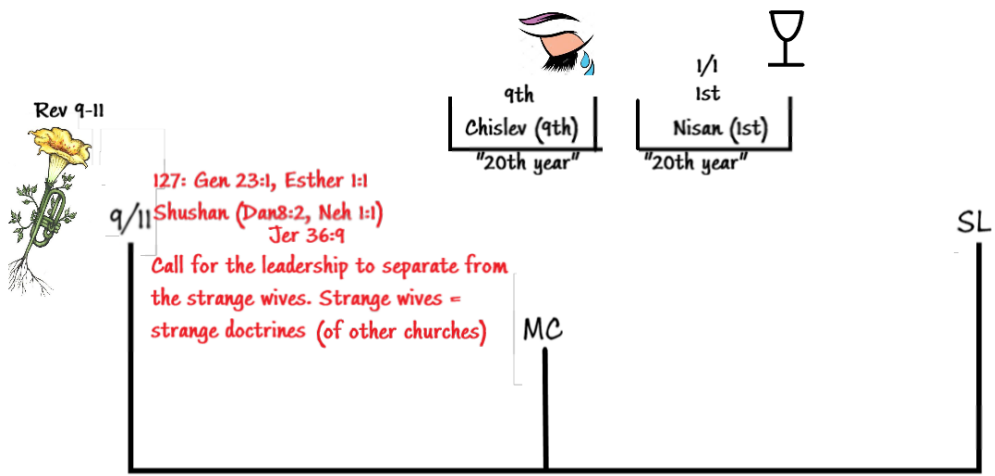

Donald Trump is the 4th president after Cyrus. Cyrus is marked in 1989. We know that GW Bush was in 2001, and times have moved on. We have applied B. Obama with

Darius I, and Darius I is not even in this history. We need to be careful how are we applying these symbols. We are not trying to say that the year 2016-17 is some kind of prophetic waymark, but what we are teaching is this: this 6 mo period is preparation to make war against Greece. The man is rising up now has all the characteristics to make him eligible to make him

antitype – Ahasuerus. Ahasuerus is this king who is reigning here (9/11 – Midnight Cry), that is why we mark “911” here Because structurally this is where Ahasuerus is placed. As we think about our study of the book of Esther this book is really the present truth. The elections that are happening now are a fulfillment of prophecy.

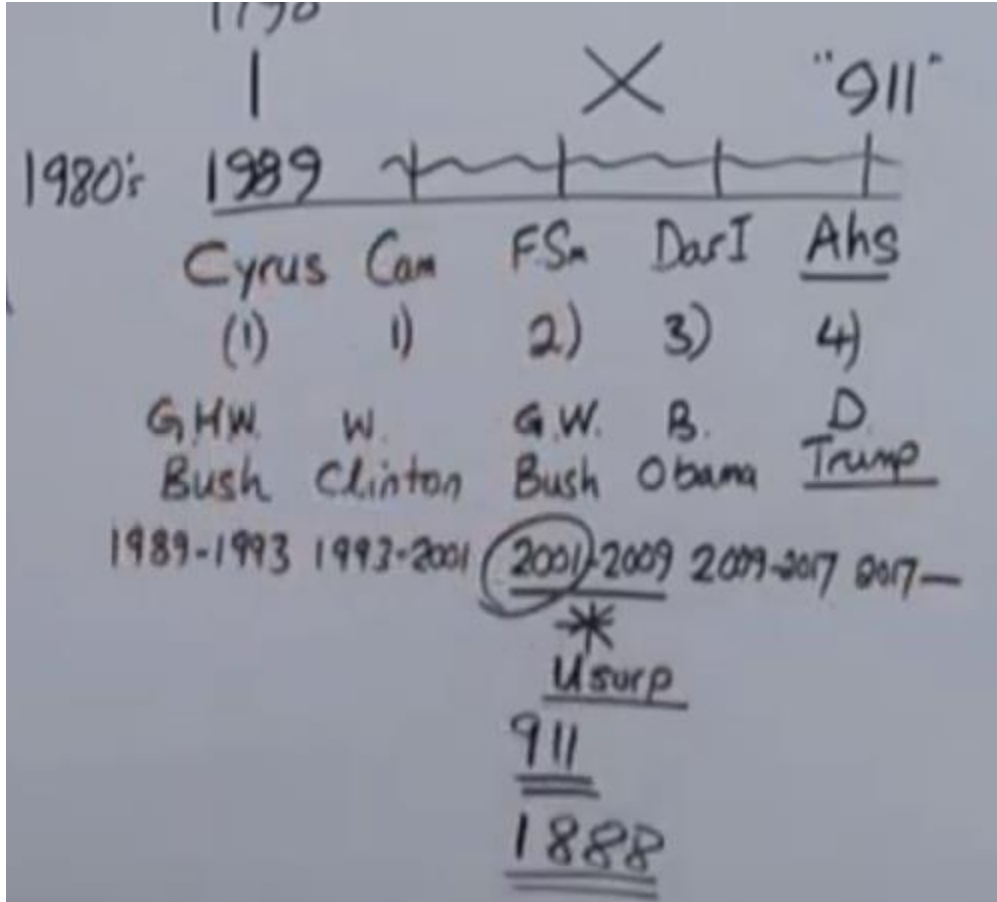

Study for yourselves if this is correct, how Cyrus lines up with the time of the end, and Bush father. He has a son usurps the throne in the year 9/11, which is a repeat of the year 1888 followed by a president who fails to take control of the world, whose son is going to rectify this issue and will collect all these provinces to do the work against the world – Greece.