



*Camp Meeting  
Guadeloupe*

Israel and Modern Babylon

12 of 15

Tess Lambert

April 2019

Review

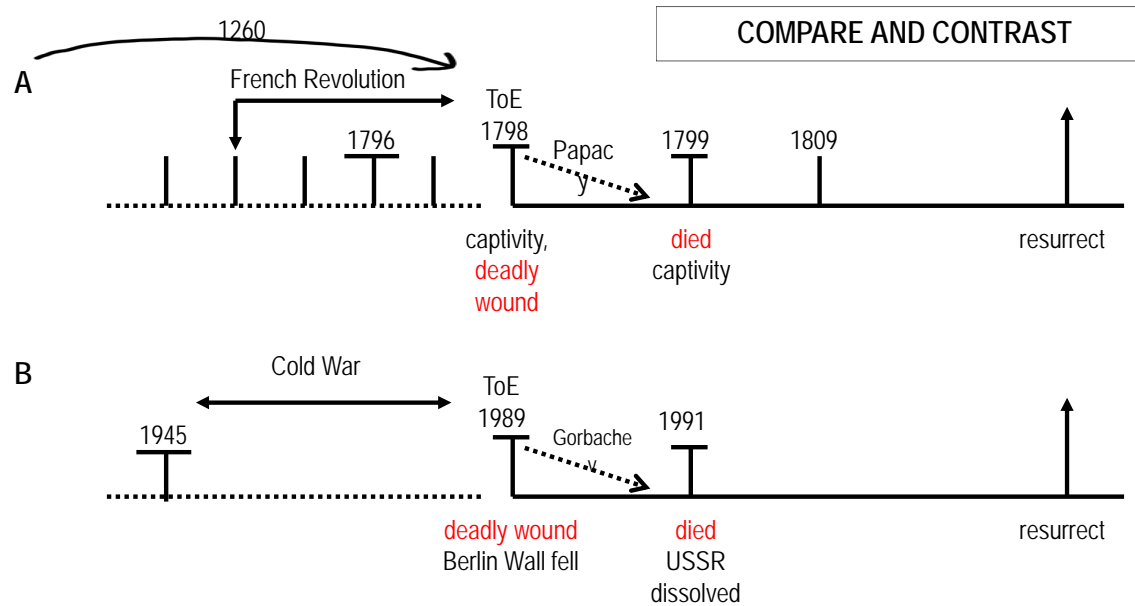

We'll do a review. In our last study we went to Daniel 11:40. Based on our understanding of parables, we wanted to see if we could come to the same understanding that we were reaching by studying history. Then we went into the history of Pyrrhus, first Acts 27 and then into Pyrrhus, and saw that there are two parts, an 'Alpha' and an 'Omega.' We also saw in Daniel 11, with Seleucus and Ptolemy, that there was the history of Raphia and Panium. Those things helped us to understand that in our history, post 1991, there would be another war between the King of the North ('KoN') and the King of the South ('KoS').

## Review

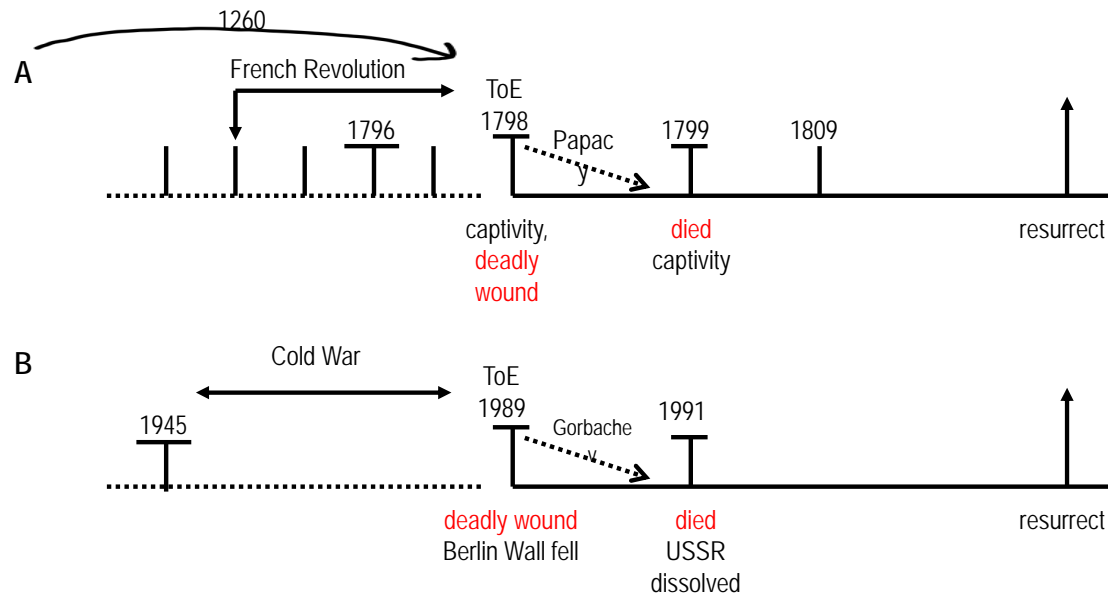

We went into Daniel 11:40, and we did a 'Compare and Contrast.' We took the history we know well, the French Revolution, the "deadly wound" in 1798, and the knowledge that it would resurrect. Perhaps we needed reminding that this is also a captivity, and that there would also have to be a death, and it's preceded by a war. Once we had all these details laid out for the 1798 history, then we were ready to approach part 'b' of verse 40.

## Review

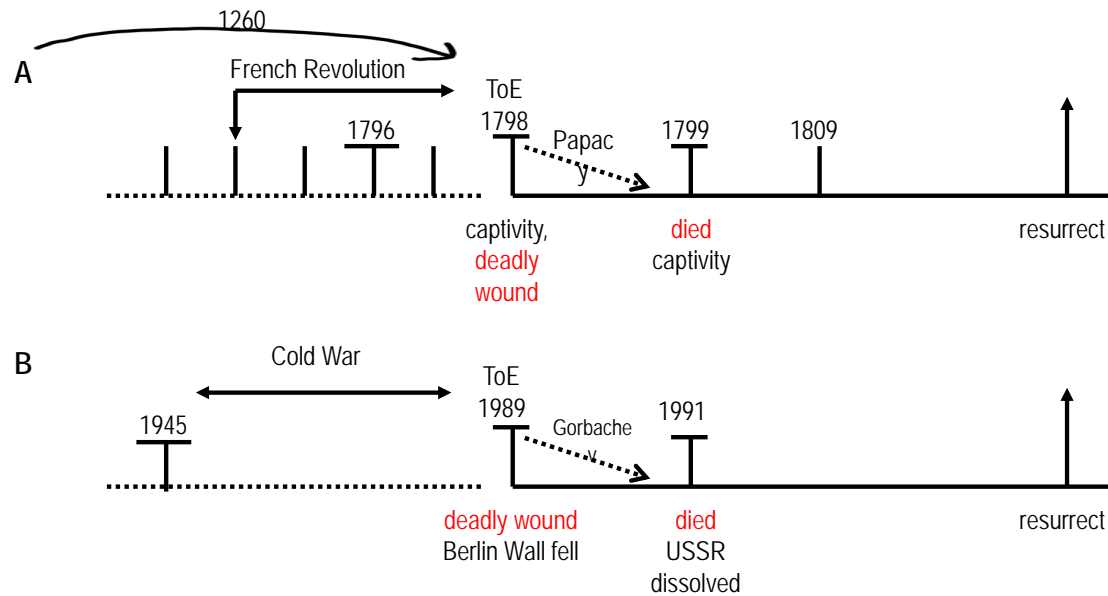

We can see a Cold War that takes us to 1989, and again we have a story of a “deadly wound,” but we have always known that the Soviet Union (USSR) did not end in 1989. Therefore, 1989 is the “deadly wound,” and its death is in 1991 with the dissolving of the USSR.

1798 is the captivity, and 1799 the death of Pope Pius VI. And then we see Mikhail Gorbachev, whose rulership is irretrievably weakened in 1989. In 1991, the same day he resigns, within the same half hour, the USSR is dissolved.

## Review

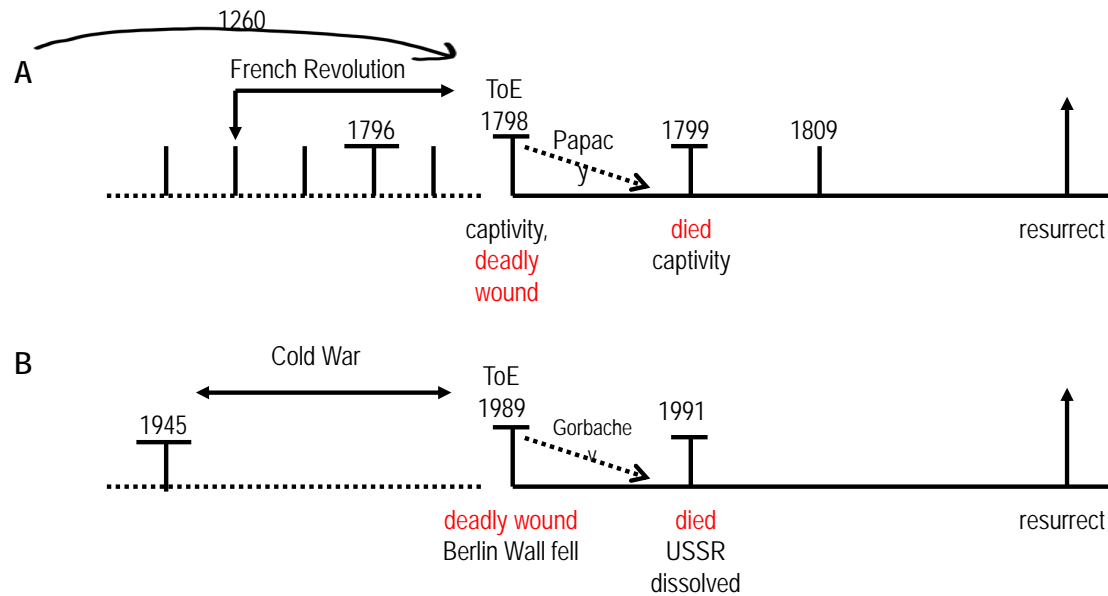

We have the story of Pius VI and Gorbachev, so then we can also draw the conclusion that it must resurrect. Even though the 'KoS' died in 1991, we already know we are entering into a time period where there is going to be a war between the 'KoN' and the 'KoS,' just as we have already understood through the Eastern Front of WWII. If we're going to see this as a "deadly wound" and a death, "he that killed with the sword must also be killed with the sword," then "he that brought God's people into captivity, must also go into captivity," and to understand the captivity requires a different 'Compare and Contrast.'

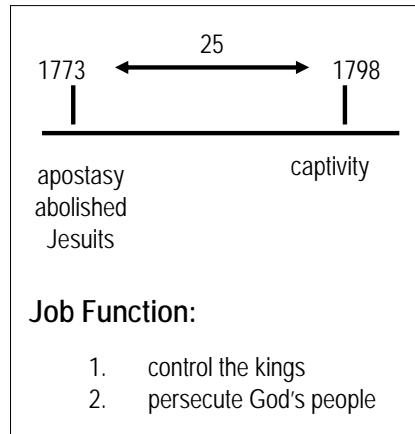
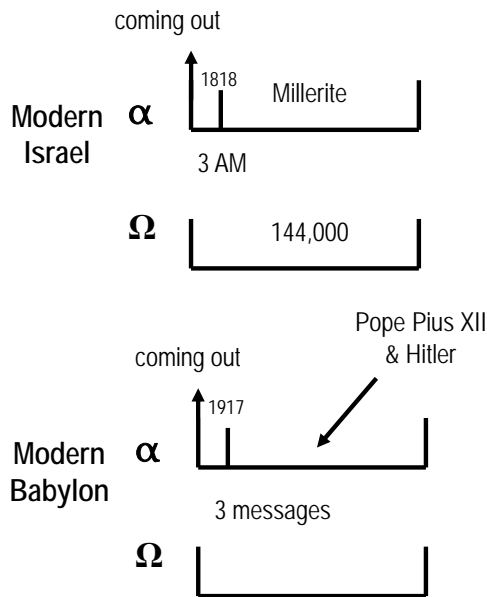

Now our parable is between 'Modern Israel' and 'Modern Babylon.' What happened to 'Modern Israel' when it came out of captivity will show us what must happen to 'Modern Babylon' when it comes out of captivity. Very briefly **we discussed why the papacy went into captivity**, and began to consider the thought about whether or not Satan's church can be in rebellion to him. If God's Church can live outwardly moral lives, and yet look to God and say, "We will not do what you request us to do," like the Pharisees did, and if they choose their own way, then why can't the papal church look to Satan and live moral or immoral lives, and say "Despite what you have asked us to do we would rather rest in our big houses, and enjoy our wealth, instead of entering into hardship and undertake the work you have asked us to do." To protect the Jesuits, and continue their job function, they would have needed to surrender temporal prosperity.

But just like God's people, the papal church decided against doing what they were told to do in 1773, and that's apostasy. If you go into apostasy, sooner or later you go into captivity, which is why you see **the papacy go into captivity in 1798**. If they are going to go into captivity, when they come out of captivity, then they come out as 'Modern Babylon.' 'Modern Babylon' is going to look like 'Modern Israel.' 'Modern Israel' is brought out by a three-step prophetic testing message: "Fear God," "Give Him Glory," because "Judgment is coming."

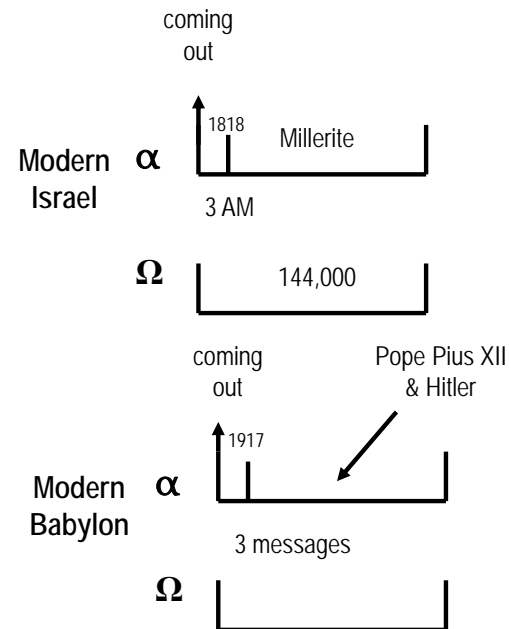

- Fatima:**
1. fear
  2. KoS
  3. judgment

In 1917, they have a three-step message: 'Fear Satan,' 'Give him Glory,' or 'You're going to be Judged.' The 'Midpoint,' the core message, is to defeat the 'KoS,' because it's 1917, Satan can see what is happening, and he needs to get his house in order before they can do a work. We've just began to consider what this looked like in 1798 and 1899.

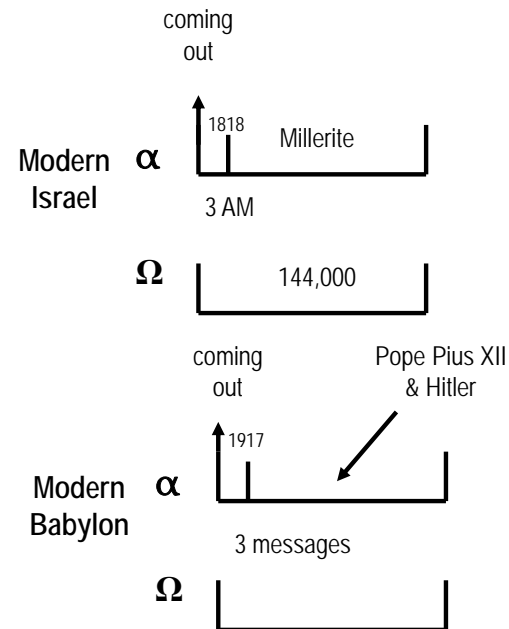

- |  |
|--|
| <b>Fatima:</b><br>1. fear<br>2. KoS<br>3. judgment |
|--|



# **‘Compare and Contrast’ ‘*Modern Israel*’ and ‘*Modern Babylon*’**

What we want to do now is ‘Compare and Contrast’ ‘Modern Israel’ and ‘Modern Babylon,’ and in doing this we will not be going into as much detail. We can spend quite a few presentations reading quotes and going into the history, but there is a separate purpose to go over this history. It is separate to just understanding the ‘Counterfeit,’ or as an exercise in parables, and there are a couple of points we need to see.



We're going to take the history of 'Modern Israel,' and see how well it lines up with the history of 'Modern Babylon,' to see how closely Satan is counterfeiting. We began to do that work when we discussed 1798, and we said this is when 'Modern Israel' becomes visible in history and comes out of captivity. That being so, without trying to prove any of it, we just want to see the history of 'Modern Israel' as the movement currently understands it.

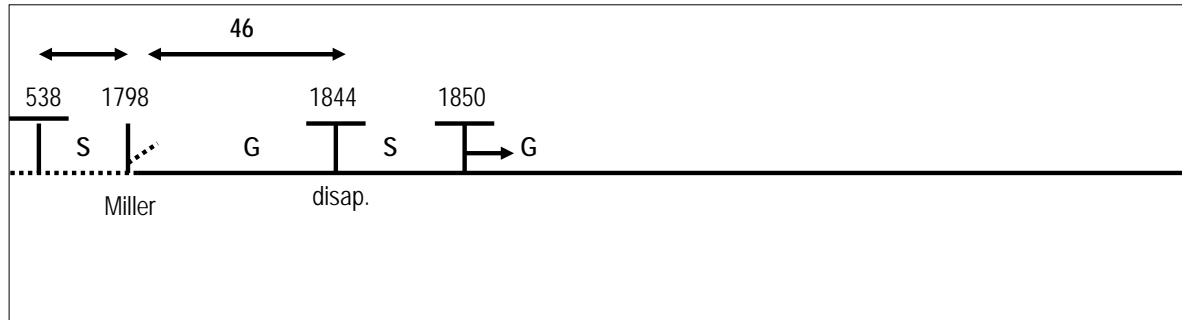

From 538 AD to 1798 there's a 'Scattering' time, the time of captivity. We are going to call it a 'Scattering.' In 1798, God's people come out of captivity, so they enter into a 'Gathering' time. It's a 'Scattering' and a 'Gathering.' In 1798 there's an 'Increase of Knowledge' ('IoK'), and someone is raised up who is going to become a new leader for God's people; this is William Miller. This 'Gathering' time lasts until 1844. There's a 46-year history of 'Gathering,' rebuilding the temple, and it ends in a disappointment, a bitter experience. We discussed that when we looked at Acts 27. God's people were scattered until 1850, and then in 1850 there was a renewed effort at 'Gathering.' You may be familiar with the 1850 Chart, and that was part of this process.

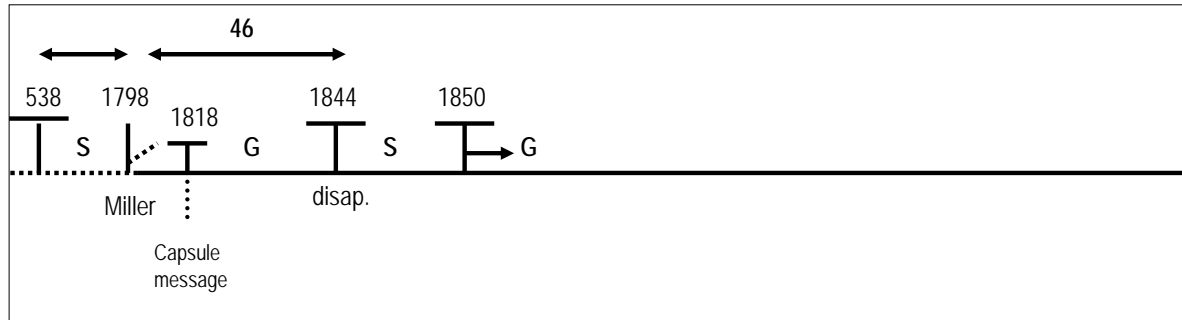

We'll paraphrase a couple of quotes. This one is in *The Great Controversy 1888 Edition*, and we will just read the first two sentences. "He had devoted two years to the study of the Bible, when, in 1818, he reached the solemn conviction that in about twenty-five years Christ would appear for the redemption of his people. "I need not speak," says Miller, "of the joy that filled my heart in view of the delightful prospect, nor of the ardent longings of my soul for a participation in the joys of the redeemed..." {GC88 329.2}

What William Miller is saying is that in 1818, he reached the conclusion that Jesus was going to return in about 25 years. So, there's an 'loK,' and by 1818 Miller has his message, and it's all in a capsule form. There are more details to come, but he understands what is happening.

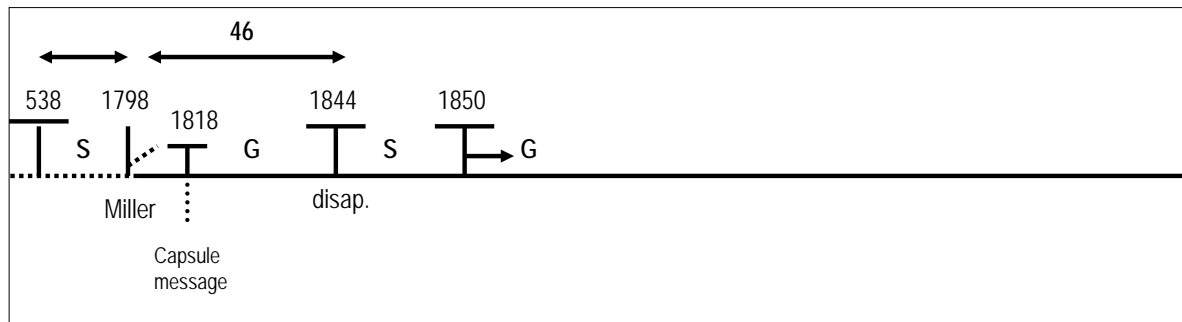

This is a quote from *The Review and Herald* and Ellen Gould White (EGW) says, *that the Lord has shown her that He has stretched out His hand a second time to gather His people*, this is towards the end of 1850. "September 23d, the Lord showed me that he had stretched out his hand the second time to recover the remnant of his people, and that efforts must be redoubled in this gathering time. In the scattering time Israel was smitten and torn; but now in the gathering time God will heal and bind up his people. In the scattering, efforts made to spread the truth had but little effect, accomplished but little or nothing; but in the gathering when God has set his hand to gather his people, efforts to spread the truth will have their designed effect. All should be united and zealous in the work. I saw that it was a shame for any to refer to the scattering for examples to govern us now in the gathering; for if God does no more for us now than he did then, Israel would never be gathered. It is as necessary that the truth should be published in a paper, as preached." (EGW, RH, November 1, 1850 par. 9)

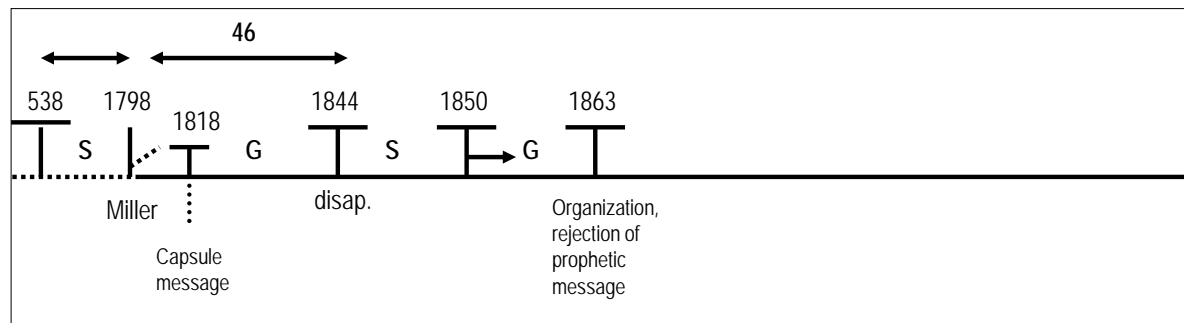

What she is saying is that God is attempting a second 'Gathering' of His people in 1850, and we saw that it also related to the 1850 Chart and the work that they were meant to do. That is when a 'Gathering' time began. We notice that by 1863 something has happened to that message? What has happened? They rejected it.

In 1863 there are a couple of issues in the church. There's organization going on. Is that good or bad? It's good, not everything in 1863 was negative. But at the same time they are organizing their work, there is a rejection. Rejection of what? Of their prophetic message. Organization was a good work, it's necessary. Rejecting the prophetic message is suicide for their mission.

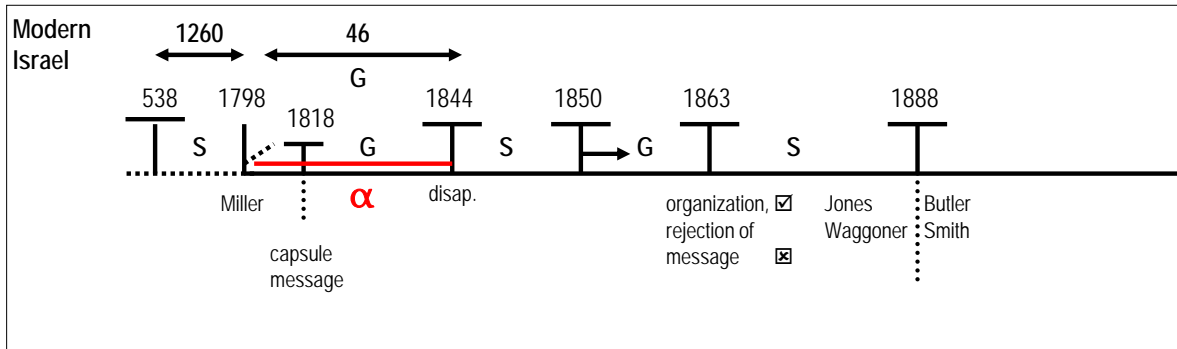

In 1863, we know they are back in a 'Scattering' time, therefore, when we come to 1888, what is meant to happen? We have the messengers of A. T. Jones and E. J. Waggoner coming into the church, and it's Jones and Waggoner versus the leadership of G. I. Butler, but you could also include Uriah Smith. There are different leaders opposing Jones and Waggoner, and Butler and Smith are holding to the 'Traditional View' of Adventism (SDA). Jones and Waggoner are coming with 'New Ideas' and it's opposed by the leadership who are supporting the 'Traditional' definition of "Righteousness by Faith." The 'Traditional View' is based on the Book of Galatians. We will discuss this more. 1888, is a "Failure," yes? It's a failed attempt.

Then we come to 1989 from 1863 even through the history of 1888 is a time of 'Scattering.' The 46 years from 1798-1844 were a time of 'Gathering.' First of all there is a time of captivity from 538-1798, and then they come out with the Three Angels' Messages ('3AMSGs') and they enter a time period of 'Gathering' from 1798-1844. It ends in a disappointment. We mark 1818 when they have their message collected. 1844, they're scattered. In 1850, there's an attempt at a 'Gathering,' but it goes nowhere, because they are entering into the Laodicean condition. From 538-1798 is a '1260,' it is a 'Scattering.' From 1863-1989 is a '126,' and is a 'Scattering,' until 1989. From 1798-1844 is the 'Alpha,' and it's the beginning of 'Modern Israel.' From 1989 forward is the 'Omega,' and it's the end of 'Modern Israel.'

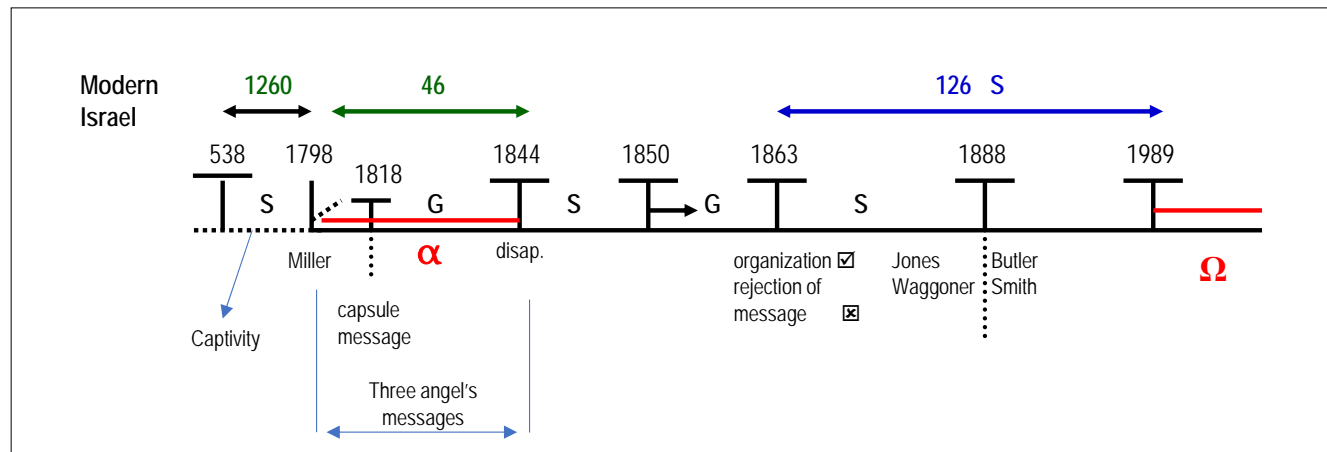



We are going to 'Compare and Contrast' what has been happening with the 'Counterfeit' since 1798. We are not going to go into all of the quotes and all the proof, partly because of time, and partly because we would read from some books that we don't have with us, and partly because we're wanting to make a separate point. We're hoping to see the logic, and then start to consider some of these things for ourselves.

In 1798 the papacy goes into a 'Scattering' time, and it begins its regathering in 1899. This is the beginning of 'Modern Babylon.' 1798 is the rising up of Miller when he buys his concordance and begins his study on prophecy.

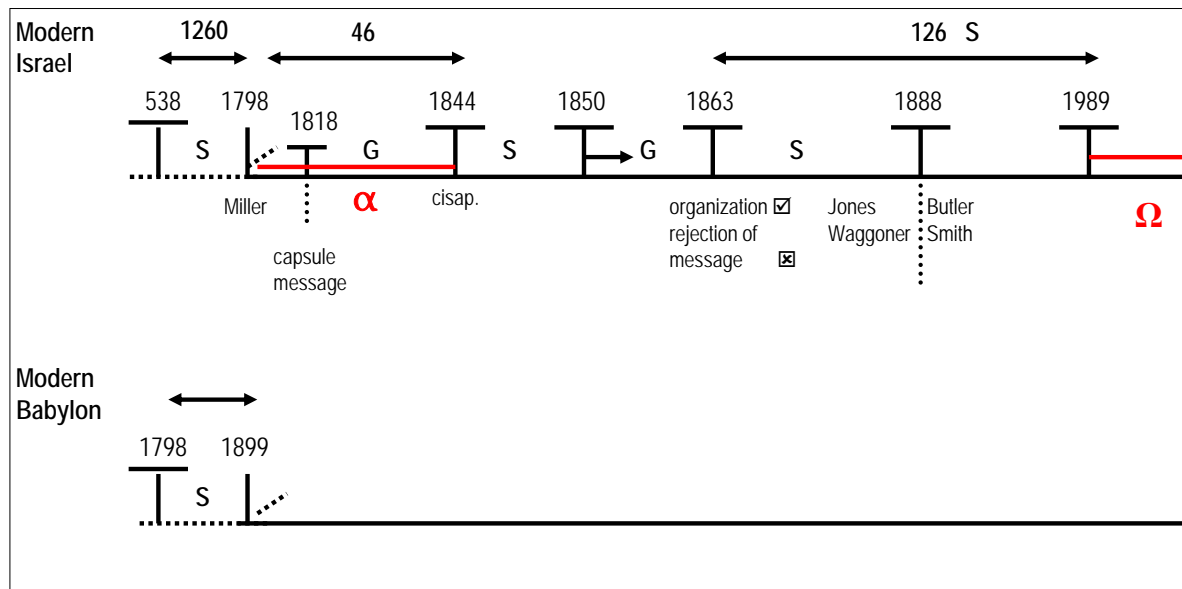

1899 is the rising up of a different man. This is Eugenio Pacelli. Pacelli comes from a family of Vatican lawyers extremely dedicated to the papacy. To give a little context, he is the grandson of Marcantonio Pacelli, who became the primary lawyer for the pope about 60 years before, so they have always had a close interaction with the papacy. His grandfather Marcantonio Pacelli, and he has a brother, Francesco Pacelli. So there two brothers, Francesco and Eugenio. They are both trained under a particular Cardinal, Cardinal Gasparri. And what this family believes is what many Catholics believed in that time period, is that it's a sin that the Catholic Church is being treated the way it is. They see it as the papacy has lost its worldly power, and they live their daily lives in protest, of what they see captivity. There are different ways they do this. They live in poverty even though they have a wealthy occupation to mirror the condition of their church. They will leave their door open to their house as a witness to people that the pope no longer has his own home, because all those papal states have been taken away so neither should they.

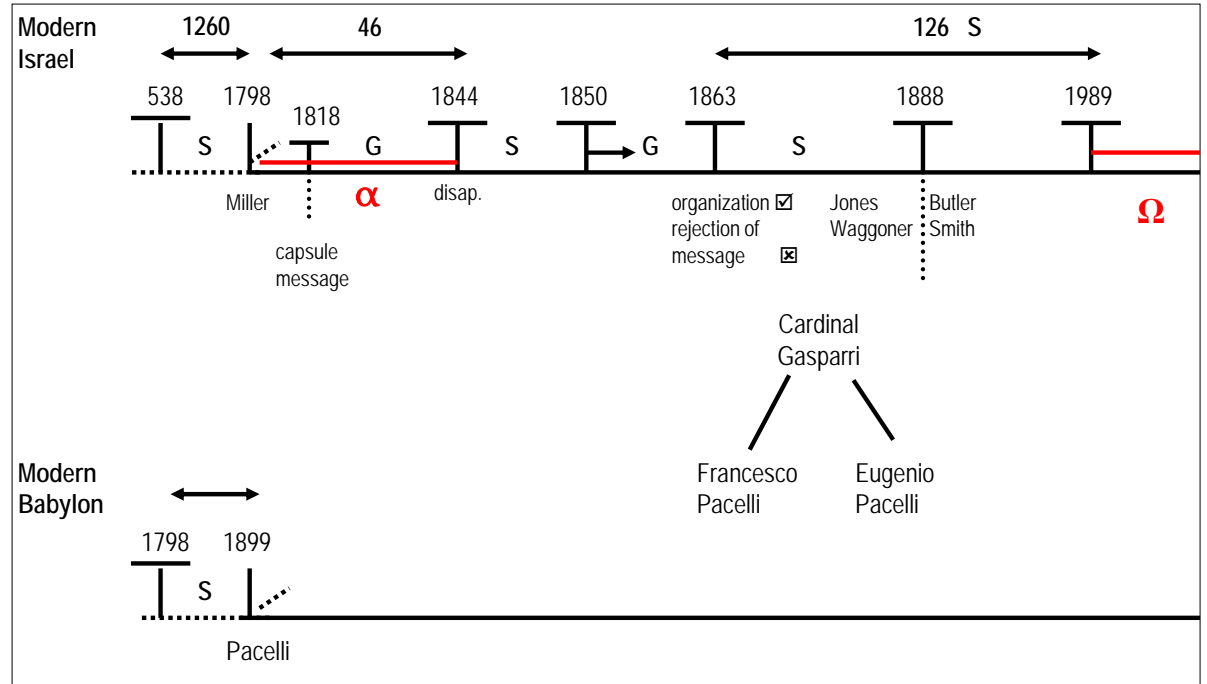

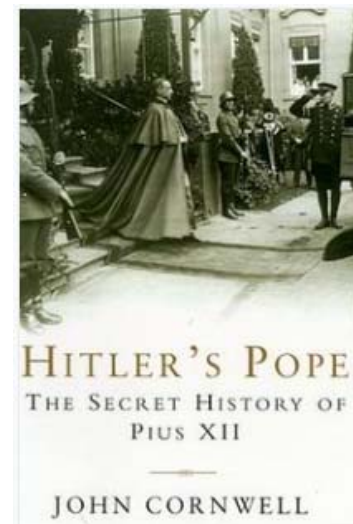
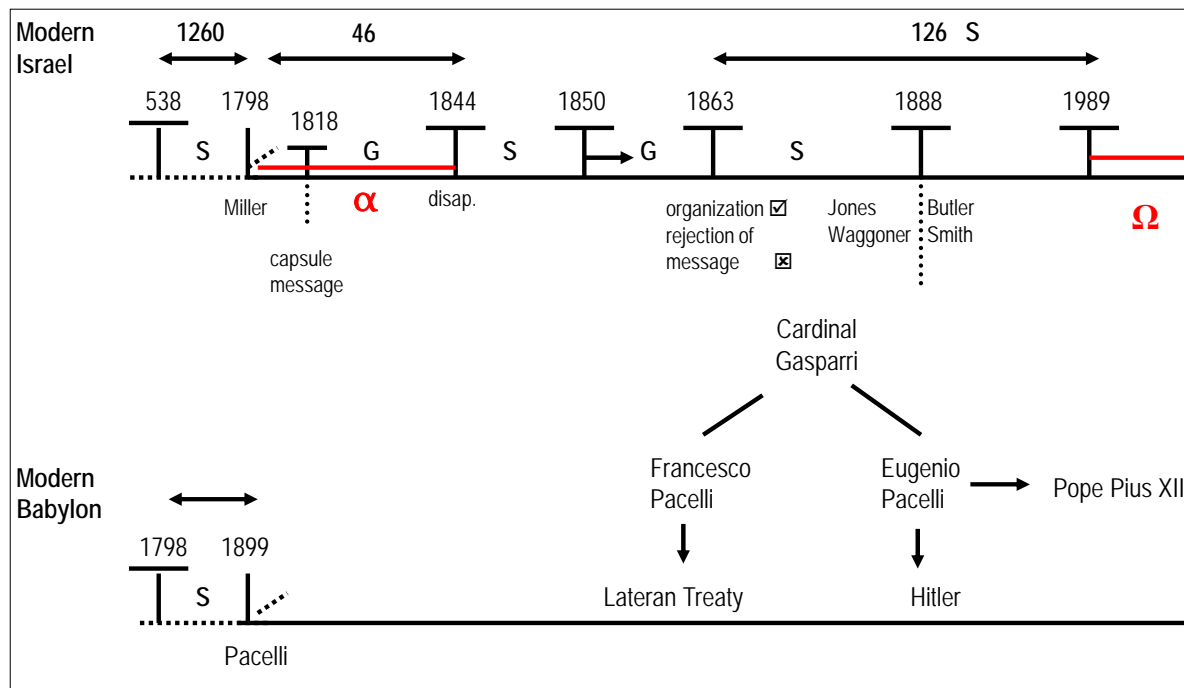

They are directly protesting the condition of the papacy. This whole Pacelli family, including these two brothers, Vatican lawyers, become involved with Cardinal Gasparri. It's Cardinal Gasparri and Francesco Pacelli who write and negotiate the Lateran Treaty. These two men are responsible for the Lateran Treaty with Mussolini. It's Cardinal Gasparri and Eugenio Pacelli who go into an alliance with Hitler in WWII, and Eugenio Pacelli becomes Pope Pius XII, the first pope to accept the 'Messages of Fatima.' So these two brothers become extremely important in this history. One is responsible for the Lateran Treaty, and an alliance with Mussolini that places Mussolini in power. The other one is Eugenio Pacelli; he goes into an alliance with Hitler, and allows Hitler to have absolute power. Therefore, you can also see the interaction with the 'Papacy and Fascism,' which is why they supported Germany, Italy with Mussolini, and also Franco in that civil war we talked about. It's Eugenio Pacelli, who became Pope Pius XII, who we want to primarily discuss.



The **Lateran Treaty** ([Italian](#): *Patti Lateranensi*; [Latin](#): *Pacta Lateranensia*) was one component agreement that made up the **Lateran Pacts of 1929**, the agreements made in 1929 between the [Kingdom of Italy](#) and the [Holy See](#) settling the "[Roman Question](#)". The treaty and associated pacts are named after the [Lateran Palace](#), where they were signed on 11 February 1929. The Italian parliament ratified them on 7 June 1929. The Lateran Treaty recognized [Vatican City](#) as an [independent state](#) under the sovereignty of the Holy See. The Italian government, at the time led by [Benito Mussolini](#) as [prime minister](#), also agreed to give the [Roman Catholic Church](#) financial compensation for the loss of the [Papal States](#).<sup>[1]</sup> In 1947, the Lateran Treaty was recognized in the [Constitution of Italy](#)<sup>[2]</sup> as regulating the relations between the state and the Catholic Church.

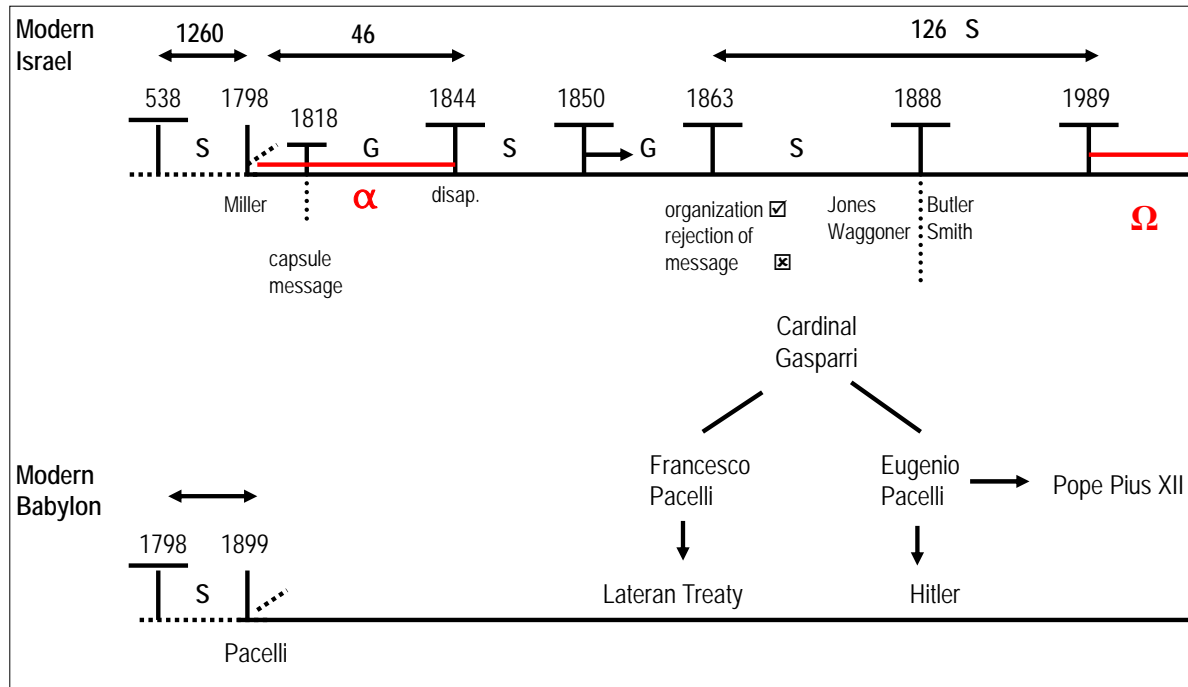

To negotiate this alliance with Hitler, he starts to study church law. First of all he becomes a priest, and then he begins to study the Code of Canon Law, the Canon Law that the papacy uses to negotiate its relationship with state governments. April 2, 1899, Pacelli was ordained a priest, and then in the autumn of that year he began at an institute to study Canon Law. It's in this studying of Canon Law that he begins his relationship with Cardinal Gasparri, and they begin to rewrite the Canon Law that they want to primarily introduce into Germany. All of this begins in 1899, when Pacelli begins to study church law. That church law is crucial to the alliance with Germany.

In 1917 we find the 'Messages of Fatima.' In 1917 an impersonation of Mary comes down to three children, primarily Lucia, and gives her a three-step prophetic testing message. There are a number of visions the children have with Mary; there are six visions. They begin on the thirteenth of May. On the thirteenth of May, Mary first appears to those children.

Also on the thirteenth of May, 1917, that exact same day, Pacelli is made an archbishop with the direct purpose of sending him to Germany to negotiate an alliance with the government, as Mary was appearing in Fatima. Pacelli, was made an archbishop directly by Pope Benedict XV, with the purpose of sending him to Germany. So the same day, the thirteenth of May, you have the beginning of the work for Pacelli, and the beginning of the 'Visions of Fatima.'

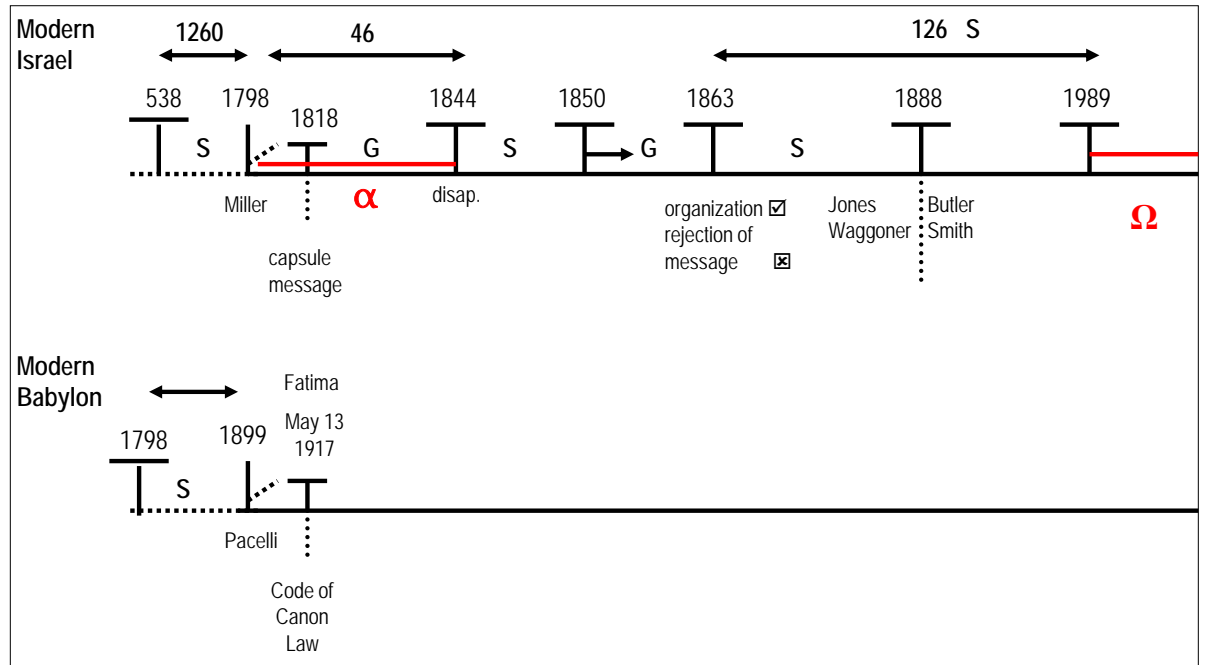

On May 18, five days later, Pacelli goes to Germany. Also in May 1917, in this same month, the Code of Canon Law is fully published. Consequently, you have Fatima, but you also have Church Law in the same month, and same year. This is for their alliance with Germany and was the work of Pacelli.

We understand 'Internally' that we have the work of the church; we go to the church and then to the world. First the church and then the world, and this is the first activity we see of the papacy. If they are going to do a work with the governments in the world, then they first need control over their own people again, and this was the purpose of the Code of the Canon Law.

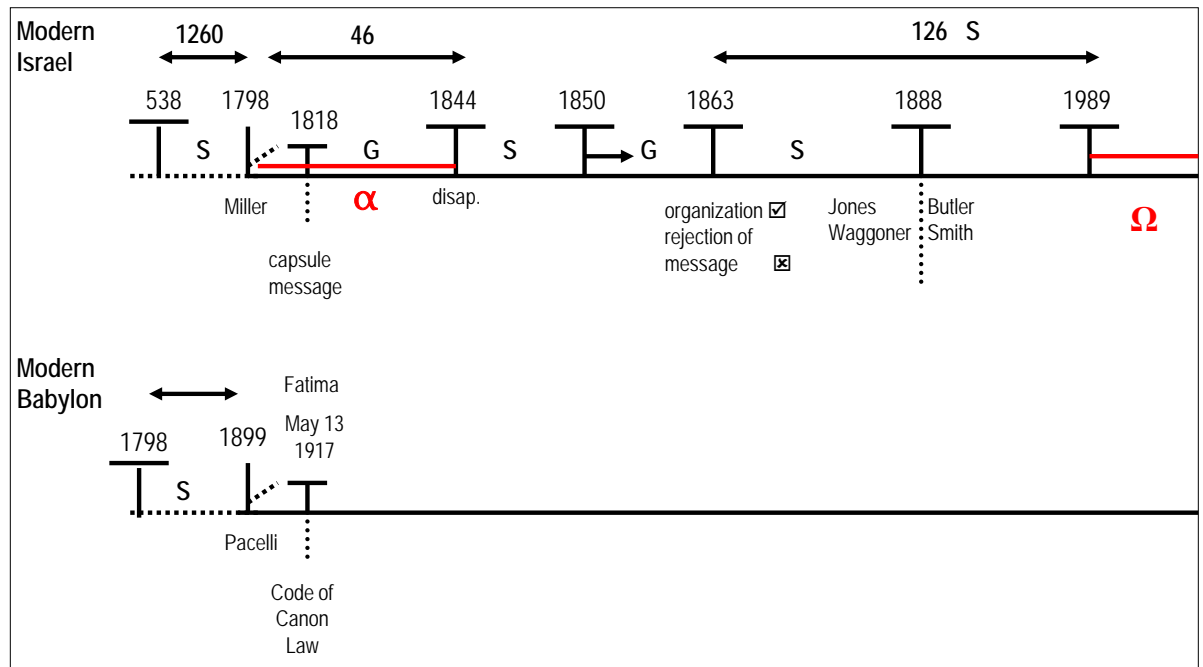

So Pacelli goes into an alliance with Hitler and that lasts through the history of WWII. How did that alliance end? It ended in 1945 with a disappointment. Why? Why is it a disappointment? He is allied to Hitler to take down the Soviet Union (USSR). Hitler lost in 1945; it was a failed attempt. You can see the papacy in a 'Scattering' time period from 1945-1950. Between 1917-1945, actually in 1939, Pacelli becomes Pope Pious XII, and he is still pope through the history of 1950. In 1950 he brings back to public consciousness the 'Messages of Fatima.' Therefore, from 1945-1950 the Catholic Church is in a 'Scattering;' they've watched the USSR sweep away Eastern Europe, the Fall of the Iron Curtain, and they are fighting for Italy to not become communist as well, and it's a dark time. 1950 is a Catholic Jubilee year, and Pacelli can see they need a revival. As a result, what Pacelli introduces in 1950 is the Dogma of the Assumption, bringing Mary back. The formal definition of the Dogma of the Assumption is that Mary was assumed in body and soul to heaven.

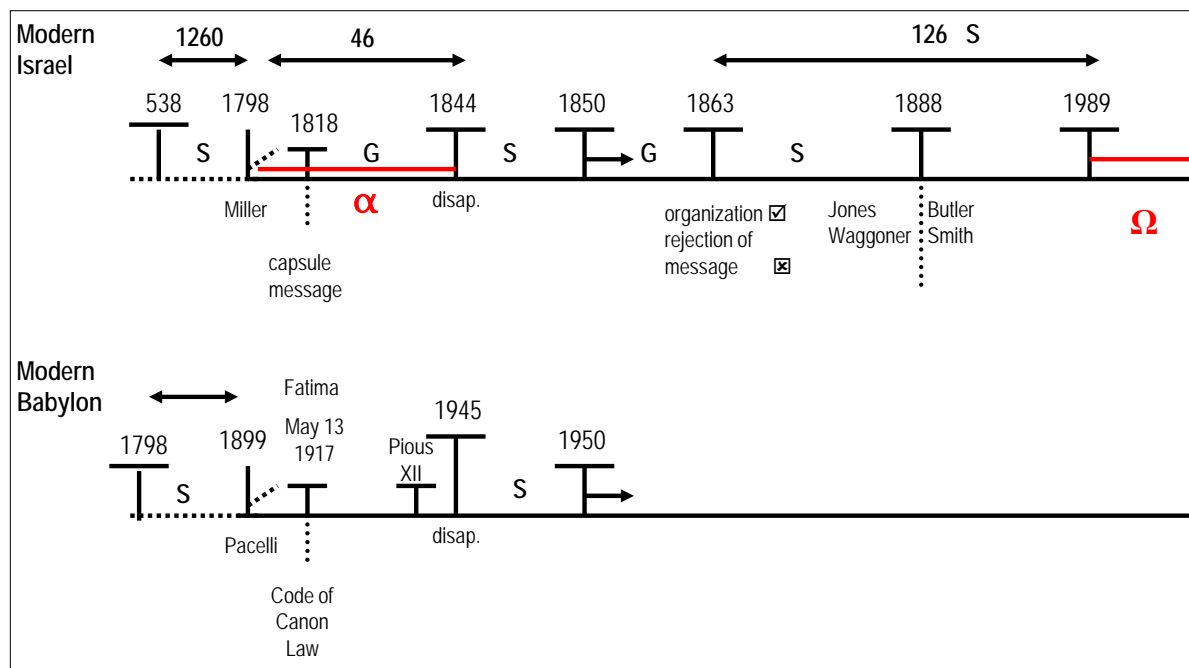



When we talk about papal infallibility, does it mean everything that they say or do can be claimed to be infallible? It does mean when they see something they can't prove they can sign their name to it, and say that as a representative of God, that they are making a formal declaration that what they have just written is infallible. 1950 is the only time that it has been used in history, with the Dogma of the Assumption. What Pacelli is trying to do, as someone that is dedicated to the 'Messages of Fatima,' is bring Mary back.



On 1 November 1950, Pius XII defined the dogma of the Assumption (Titian's *Assunta* (1516–1518) pictured).

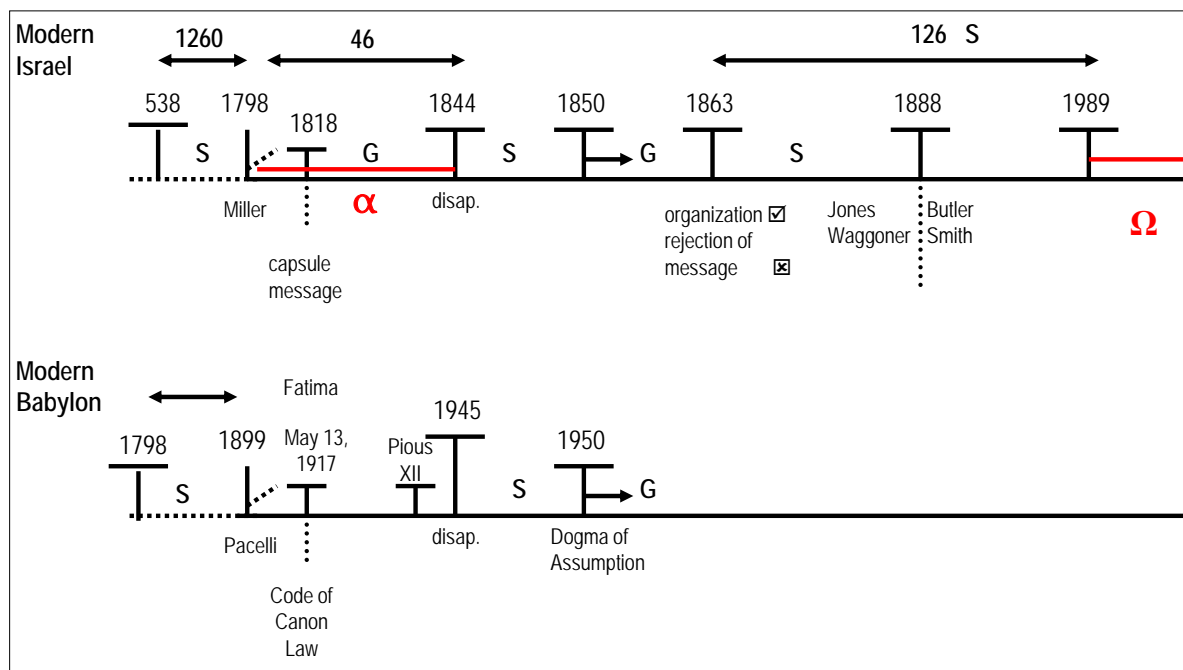

We're reading from a book titled, *Hitler's Pope: The Secret History of Pius XII*, and he (Cornwell) says, "that the timing for the Dogma of the Assumption was intentional, because Franco in Spain, another fascist, was using Mary and her Assumption as a rallying cry against Communism. In this history of 1950, Pacelli claims to see the same mystical experiences experienced at Fatima. He says that he actually experiences Fatima in 1950, and all of the signs in heaven they claim to have then." Pacelli's attempt failed. In 1958 this pope dies, and in comes a new pope. Pope John XXIII (Cornwell, 1999).

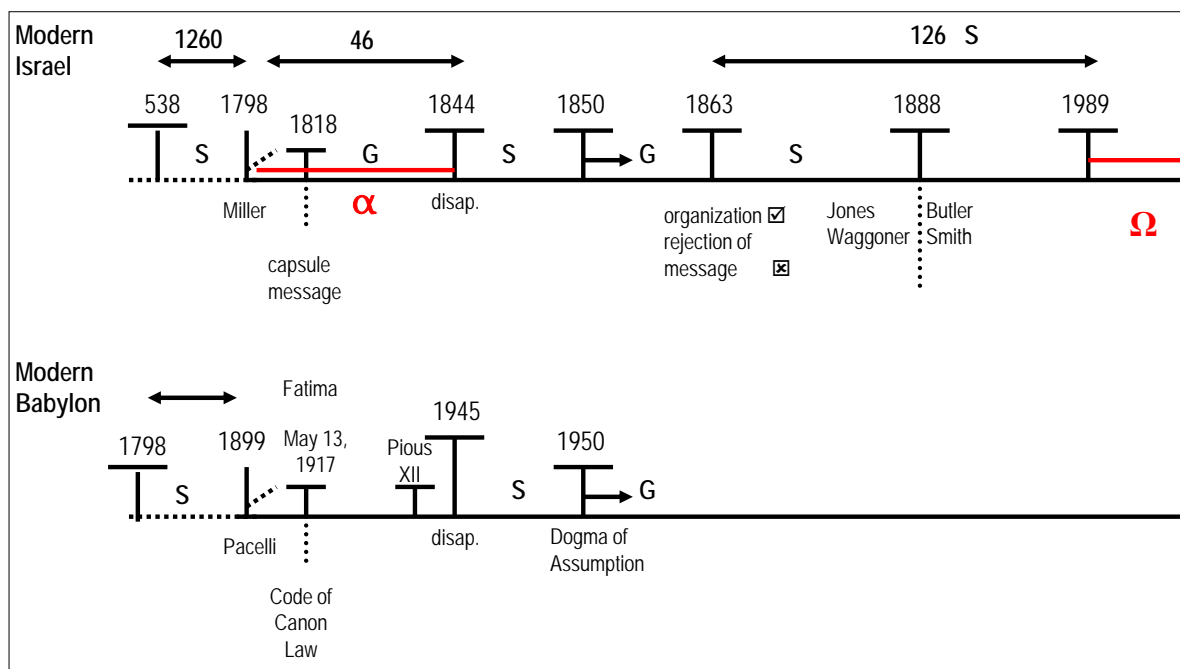

In 1959, Pope John XXIII called a council as he wanted to look at the renewal of the Catholic Church, and bring back Christian unity in the Second Vatican Council. The Second Vatican Council begins. What is the Second Vatican Council about? The Second Vatican Council in 1962 was a reorganization of the Catholic Church structure. This is what conservative Catholics have warred against ever since. A strong 'Conservative' Catholic would say that this was of Satan, that their church was in apostasy, and that the leadership was in apostasy, even the pope himself. There are tens of thousands of conservative Catholics who say that the pope today is a representative of the antichrist, because they refer back to the Second Vatican Council and call it apostasy.

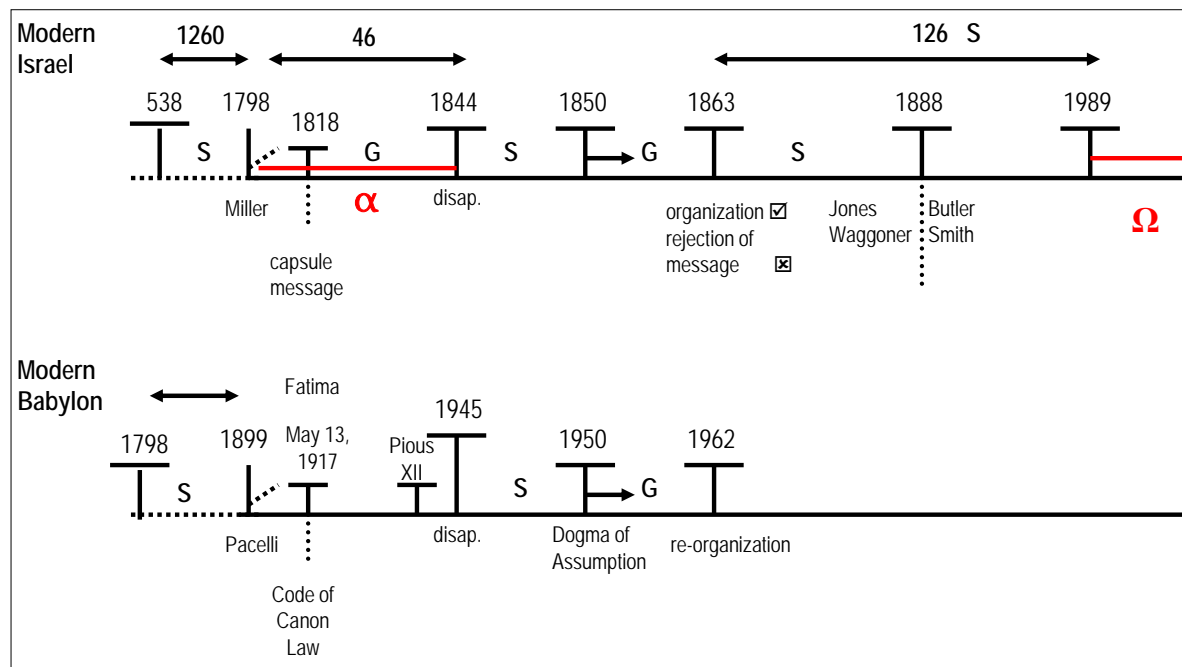

From a Catholic point of view, this call for unity to reorganize their church was not a bad thing. All 'Conservative' Catholics wanted to use the Second Vatican Council to condemn 'Modern' heresy and 'New' doctrines, but that didn't happen. Instead, the thought that was introduced was that the Catholic Church should develop and change with society and history, and experience radical reformation. From the view of the 'Counterfeit,' that was a good thing, they needed it.

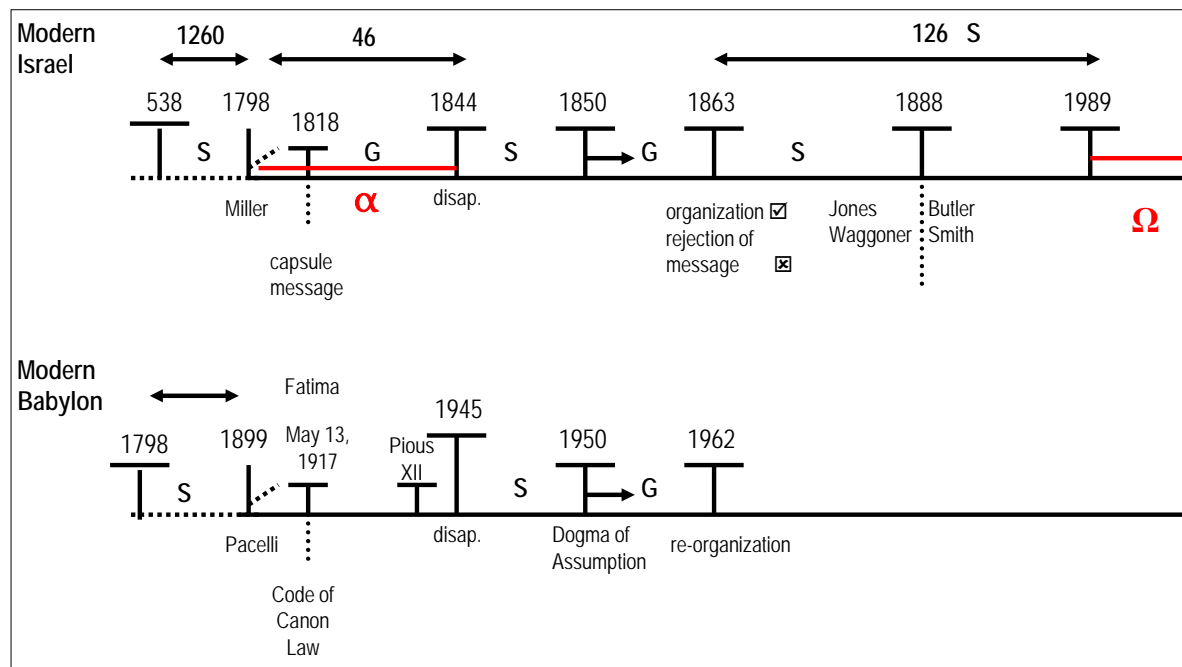

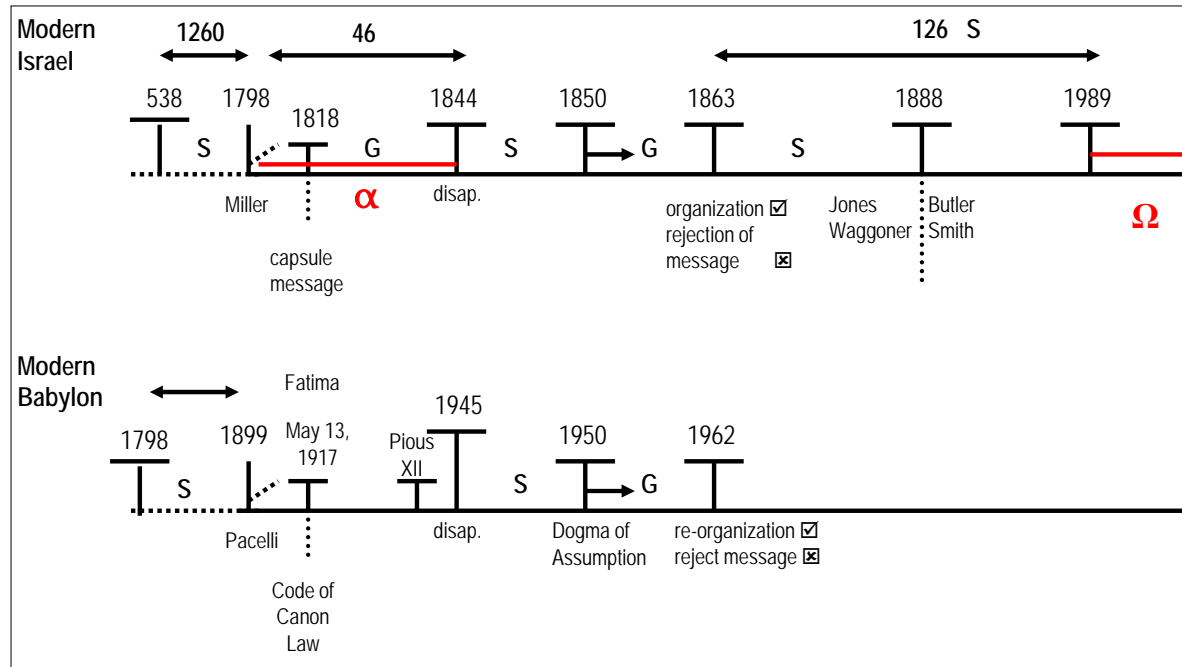

This Second Vatican Council took place over a period of time, and something else happened in 1962; there was a meeting. **What is the purpose of the Catholic Church now?** It is not to persecute God's people, or control the kings. **They were given a job function in 1917. What was that job function? To destroy the 'KoS,'** and this is a new Pope, John XXIII. In 1962 he is in the Second Vatican Council, and he wants to encourage unity with the other churches. There is one church that he wants, but he doesn't have access to it, and that is the Russian Eastern Orthodox Church, and they can't come because the USSR won't let them. Then in 1962 there was a secret meeting. They met in France and this meeting was between representatives of the Soviet Union and representatives of the Catholic Church; especially, one cardinal in particular. What they negotiated, was an agreement.

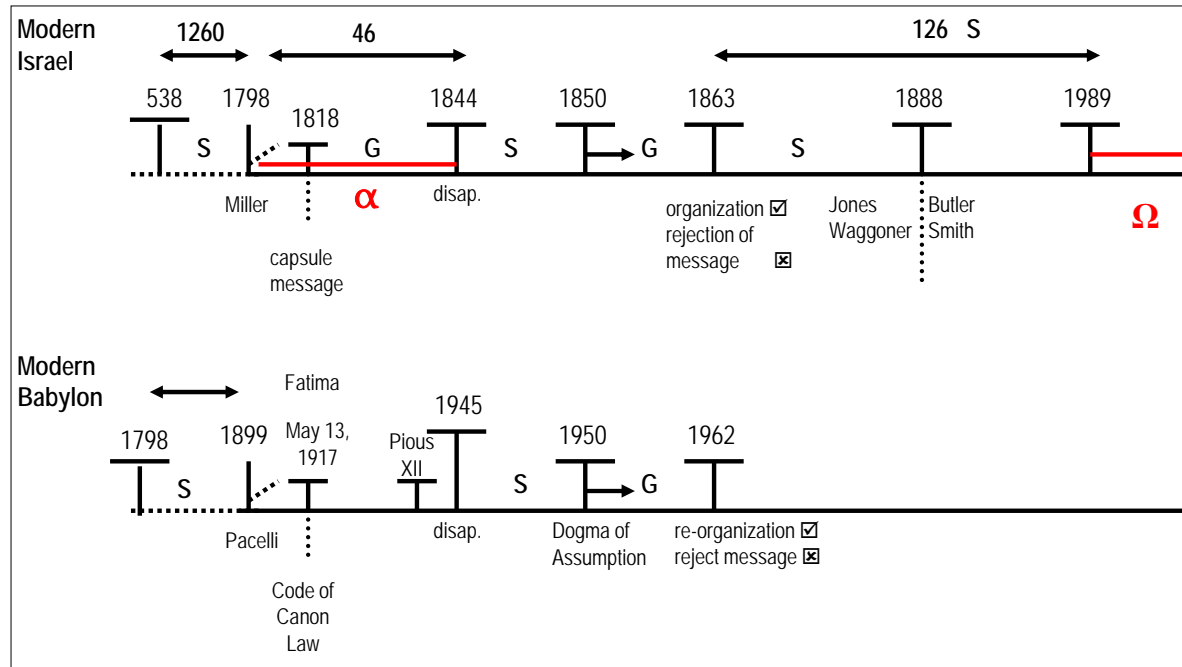

Come 1962, the Catholic Church is ready to do something at the Second Vatican Council. They have drawn up all these papers, which is a document that is a strong condemnation of Communism, and they were supposed to make the strongest condemnation of Communism that they have ever made. They never read that, or released that document, but it is in their archives. You can find it, but it is still written in Latin and it was never read. The reason they chose not to condemn Communism, is because they went into a secret agreement with the USSR. If the Eastern Orthodox Church is allowed to attend the council, the Vatican promises not to condemn Communism. They 'Compromise,' and it is a clear rejection of their job function given at Fatima. This is 'Compromise' (1962), the secret alliance between the papacy and the 'KoS' that they were meant to destroy. The popes in that time, beginning with John XXIII, were not so against Communism, because they were not listening to their prophet.

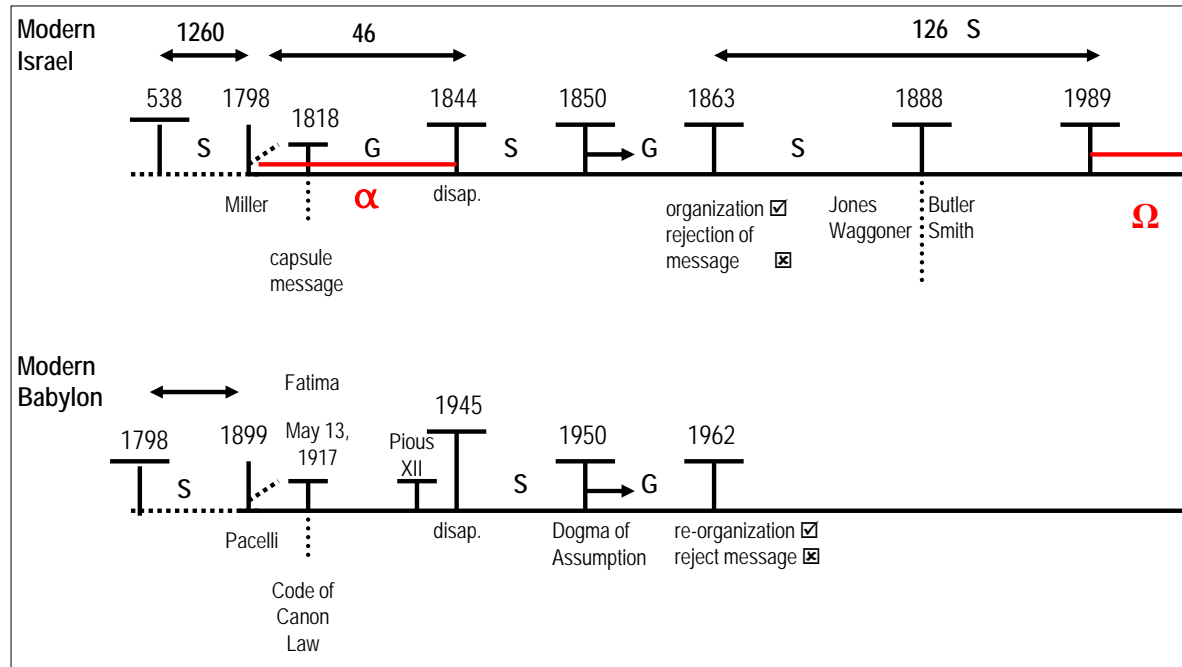

This is about the history of Lucia (1917-1962). She is alive until 2005, but these popes were too proud to meet with her and refused to listen to her. Particularly, the ones that come in this history (1950-1962), because they rejected the 'Messages of Fatima.' There was some pretense, but they never lived up to that cause.

Now we have a series of popes all rejecting Fatima until 1989, and then you have a new pope, John Paul II. We've discussed this briefly. John Paul II was made pope in 1978. A couple of years later in 1981, there are two assassination attempts. On who? One was John Paul II, the other one was Ronald Reagan. Close together were these two assination attempts on their leadership. I just want to note, when did James White die? 1881. 1881 parallels 1981.

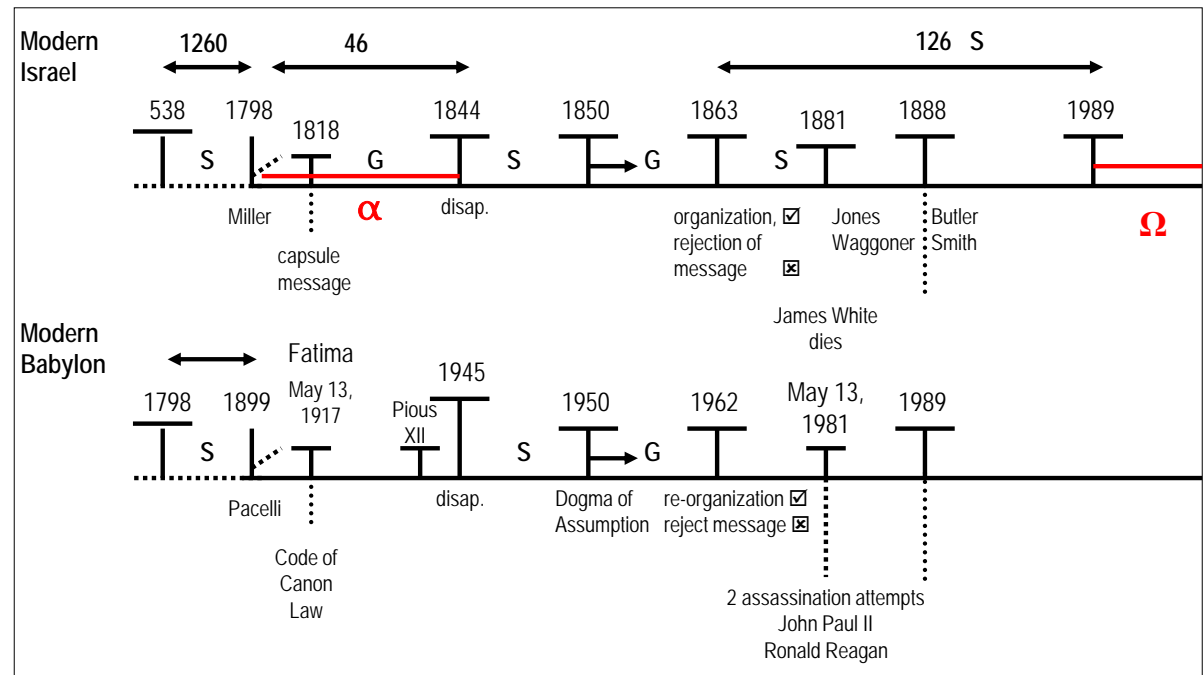

When John Paul II is shot, he almost dies, and then when he survives and he can communicate, the first thing he wants is to get access to the written 'Messages of Fatima,' because he was shot on the **thirteenth of May 1981**. He isn't entirely sure what this Third Message meant. The First Message is 'Fear.' The Second Message is the King of the South ('KoS'). The Third Message is the 'Judgment' that will happen if they do not fulfil the Second.



He well knows in this history (of the past), that they have failed the Second ('KoS'). His church has been in apostasy, and he connects the thirteenth of May in 1917 with the thirteenth of May in 1981. He believes that this assassination attempt was the 'Judgment,' because he didn't dedicate Russia, which is why from 1981, particularly through this history, John Paul II is determined to break down the USSR. It's not all about freeing Poland; it's a 'Life and Death Message' for the Catholic Church.

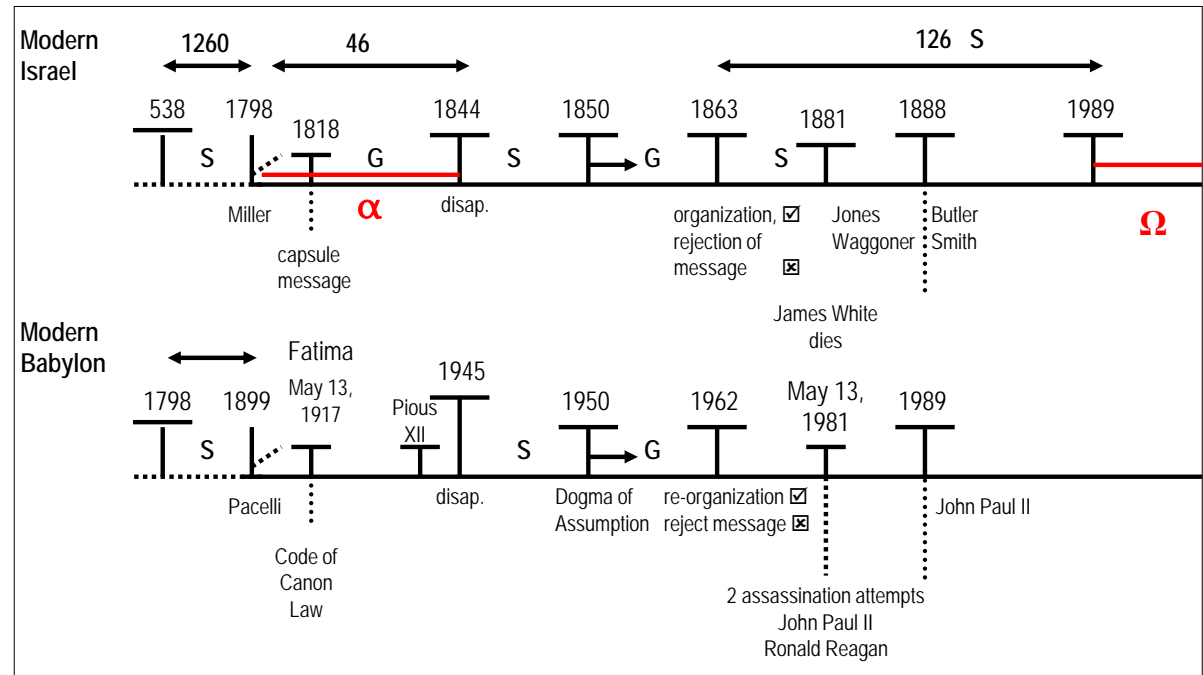

When we come to the history of 1989, and we have discussed this before, was it 'Success' or 'Failure?' What did John Paul II want? He wanted more than the Fall of the Soviet Union (USSR). He failed on a number of fronts. One of them was 'External.' The satellite states of the USSR, as the USSR was collapsing, chose Western Democracy as their leadership, and that was never meant to happen.

John Paul II was almost as much against Democracy as he was against Communism, and he was vocal about that. What they were supposed to choose was the authority of the papacy. After this history in 1991, he becomes so angry that when he visits Eastern Europe, in this history (after 1989), that we don't hear much about those visits. Before the Fall of the Soviet Union tens of thousands of people would show up, and the vast majority of them never show up after the Fall of the USSR.

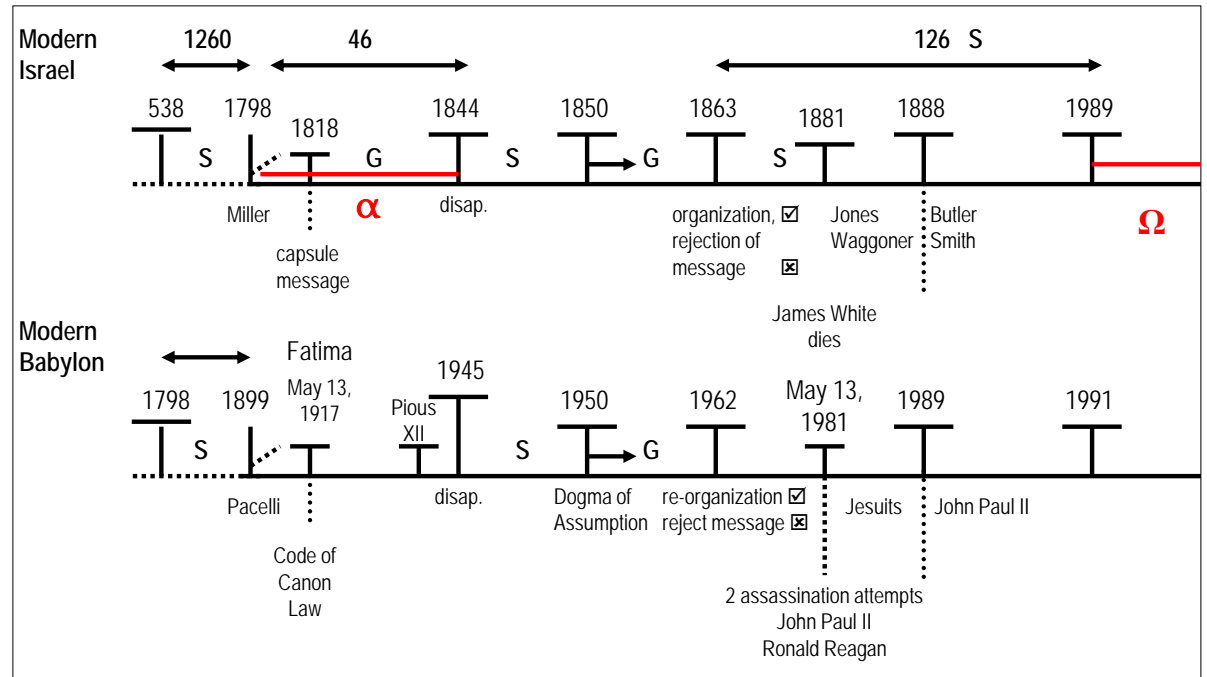

The reason they don't show up is because he has offended so many of them. Time after time, he is condemning them for their choices, for not listening to the authority of the Catholic Church, for choosing Western Capitalism and Democracy, for not sticking to church teachings, and for all their strong 'Conservative' issues. And this 'Internal' issue is directly related to that, because John Paul II is a strong 'Conservative.' He believes in the 'Traditional' teaching of the Catholic Church that it has held for over a thousand years. And he is directly opposed by the Jesuits, so the Catholic Church is split on the inside.

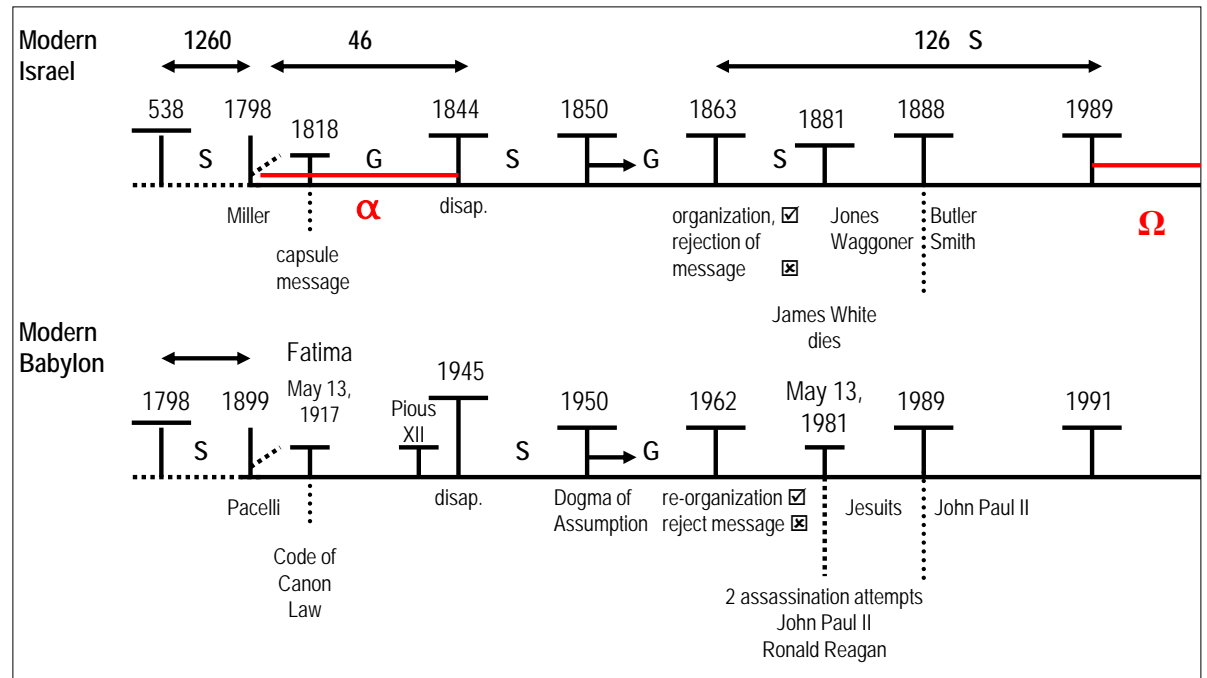

1888 failed, it was split on the inside between Butler and Smith, and the leadership who were holding to the 'Traditional Views' of the church. And they were in opposition to this 'New Light' from Jones and Waggoner on "Justification by Faith."

John Paul II is all about works, holding to those 'Old Catholic Ideas' of birth control, the role of women, their priesthood, all those different issues, and in come the Jesuits with 'Radical New Views.' It's a split within the Catholic Church.

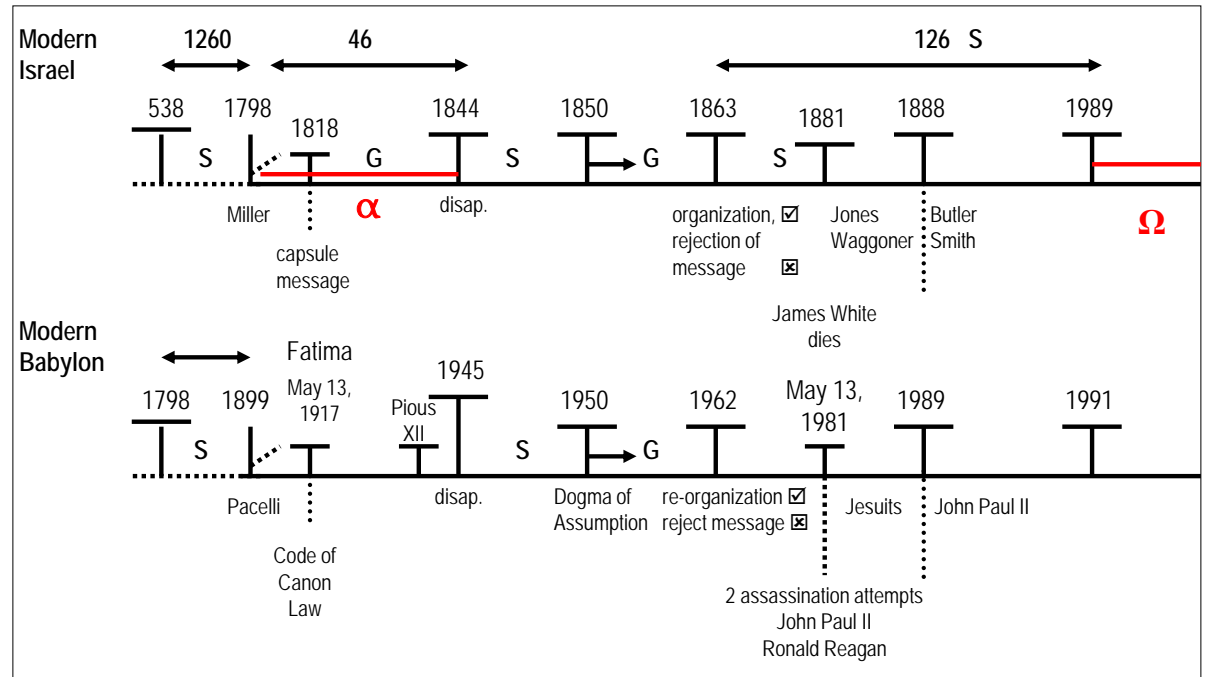

So this is the history from the beginning of 'Modern Israel' into their 'Omega' history. This is the history of the beginning of 'Modern Babylon.' We can see them in the 'Scattering' time (1798-1899), and they come out of 'Scattering' in 1899 with the rising up of Pacelli.

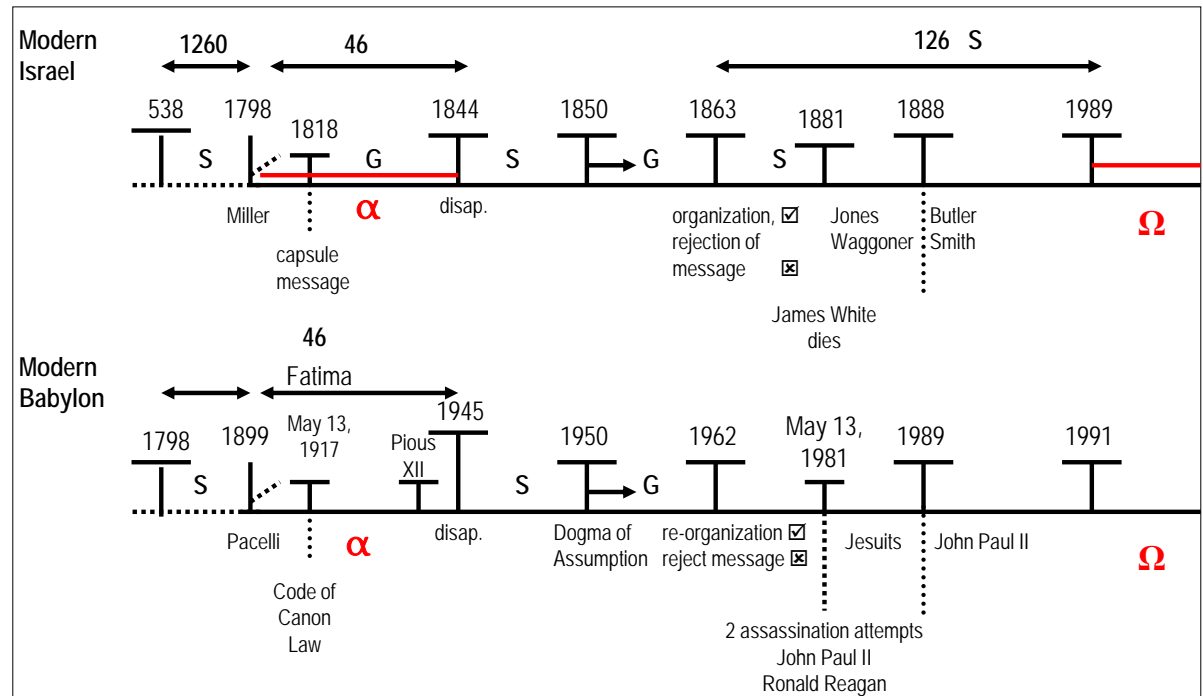

Can you pick the 'Counterfeit?'

1798 (Rise of Miller) = 1899 (Rise of Pacelli)  
 1818 (Miller's Message) = 1917 (Message of Fatima)  
 1844 (Disappointment) = 1945 (Fatima Disappointment)  
 46 years (1798-1844) = 46 years (1899-1945)  
 1850 (Chart) = 1950 (Dogma of the Assumption)  
 1863 (Organization and Rejection of Their Message) =  
 1962 (Reorganization and Rejection of Their Message)  
 1881 (Death of Leadership – James White) = 1981  
 (Assassination Attempts on John Paul II and Ronald  
 Reagan)  
 1888 (Jones and Waggoner 'New Light' vs The  
 'Traditional' Church Leadership – Butler) = 1989 (The  
 Jesuits vs John Paul II)

The Jesuits 'Radical New Thoughts' vs John Paul II  
 'Traditional' Church Teachings  
 The Jesuits 'Radical New Thoughts' are really in regard  
 to our 'Counterfeit,' of "Righteousness by Faith."

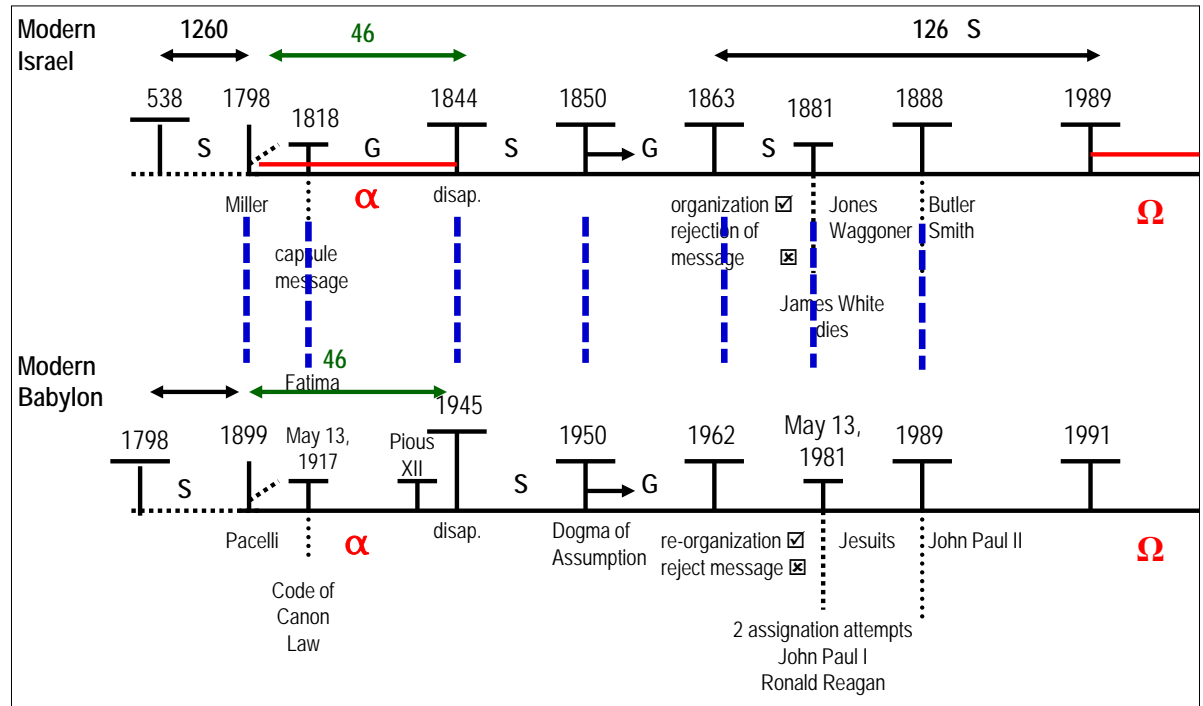

When we come to our reform line, then the history of the papacy becomes much more detailed, because they are having the same trouble as we are having. Satan 'Counterfeits' Christ's work with his church, and then repeats the same with his (Satan's) own church. Hence, we have the history of 1899-1945, with the two World Wars, and 'Counterfeiting' the "First and Second Angels' Messages."

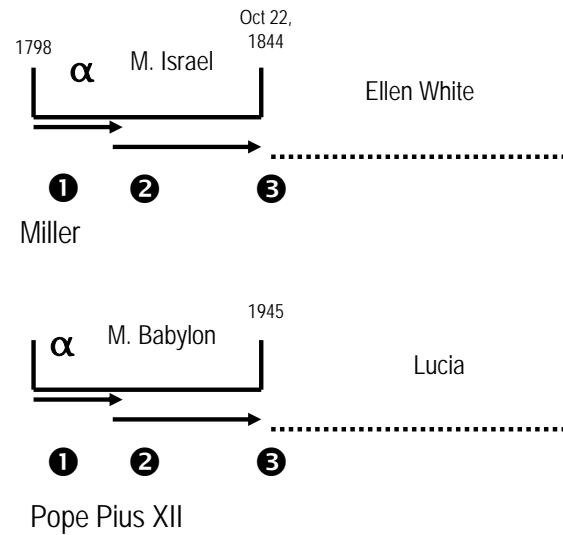

**Why did the papacy go into captivity?**

**The rebelled against their boss, Satan  
Failed to do their job function**



When did the papacy go into captivity?

1798

# What brought the papacy out of captivity?

## A 3 step message

Fatima:

1. Fear
2. KoS
3. Judgment

What was the core message for the Papacy?

To defeat the King of the South

Through the history of WW2 how did that alliance between Pacelli and Hitler end?

It ended in 1945 with a disappointment.

Why is it a disappointment?

He is allied to Hitler to take down the Soviet Union, Hitler lost in 1945. It was a failed attempt.

In 1950 Pacelli sees the church needs a revival.  
What does he do?

Pacelli introduces the Dogma of the Assumption, he brings Mary back.

What is the second Vatican Council about?

The second Vatican Council in 1962 was a reorganization of the Catholic Church structure.

At the Vatican Council in 1962, what is the  
purpose of the Catholic Church now?  
What is that job function?

To destroy the King of the South.

What church does the Pope want access to that it doesn't have in its plan to encourage unity?

The Russian East Orthodox Church



In 1981, what two leaders were involved in an assassination attempt?

John Paul II and Ronald Reagan

1981 parallels what year and why?

1881, the death of James White

What did Pope John Paul II want access to  
when he recovered?

The messages of Fatima

Why?

Because he was shot on May 13, 1981

May 13, 1917

On May 13, 1917, the three children took their flocks out to pasture in the small area known as the Cova da Iria (Cove of Peace). After lunch and the Rosary they suddenly saw a bright flash of something like lightning, followed quickly by another flash in the clear blue sky. They looked up to see, in Lucia's words, "A lady, clothed in white, brighter than the sun, radiating a light more clear and intense than a crystal cup filled with sparkling water lit by burning sunlight." The children stood there amazed, bathed in the light that surrounded the apparition as the Lady smiled and said: "Do not be afraid, I will not harm you." Lucia, as the oldest, asked her where she came from.

The Lady pointed to the sky and said: "I come from heaven." Lucia then asked her what she wanted. "I have come to ask you to come here for six months on the 13th day of the month at this same hour. Later, I shall say who I am and what I desire. And I shall return here yet a seventh time."

Again, what are the messages of Fatima?

The 1<sup>st</sup> is "Fear"

The 2<sup>nd</sup> is "the King of the South"

The 3<sup>rd</sup> is "the Judgment" that will happen if you do not fulfil the 2<sup>nd</sup>.

Was 1989 success or failure?  
What did John Paul II want?

He wanted more than the fall of the Soviet Union. He failed on a number of fronts. One of them was external. The satellite states of the Soviet Union, as the Soviet Union was collapsing, chose Western Democracy as their leadership and that was never meant to happen.