

# RUTH BADER GINSBURG

Tess G. Lambert  
Portugal  
March 2020

# LOOSE ENDS

We're going to tie a few loose ends together, and remind ourselves of some important points; so we can see that everything is connected.

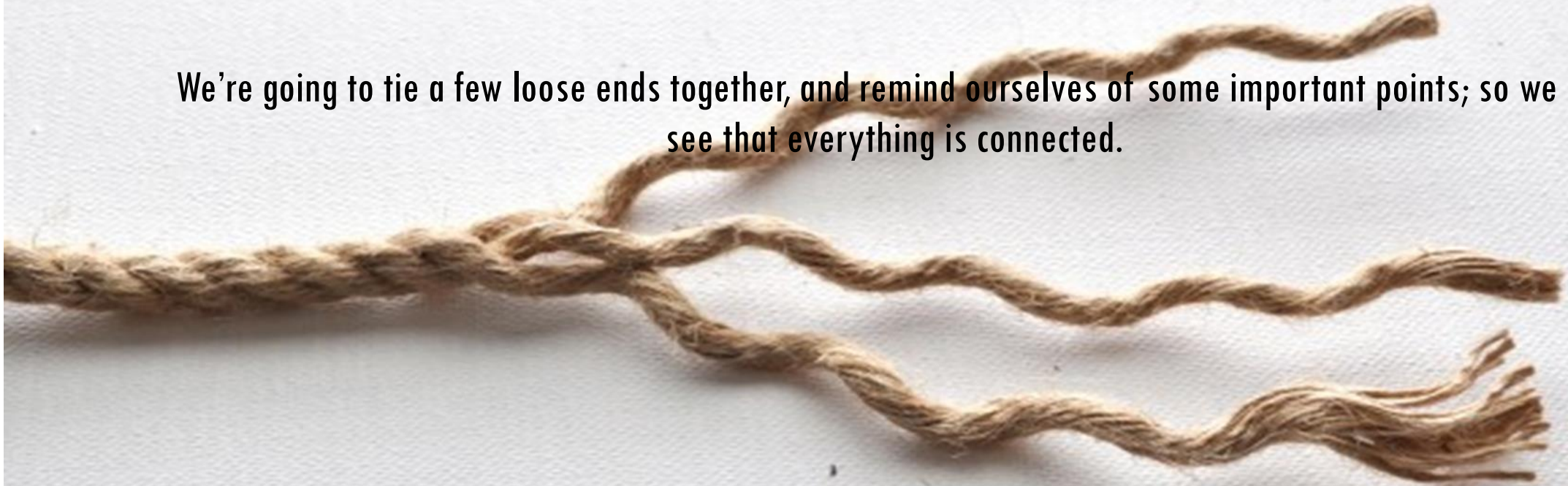

# DISPENSATIONS

First, we looked at the dispensations.

There are always four dispensations in a reform line. We looked at how the messages in each dispensation are the same message.

Then we focused on the Latter Rain dispensation; we saw how the message started with World War I and World War II and ended with Equality. That message's main subject was the King of the North and the King of the South. There is more than just that though, there are smaller connected parts.

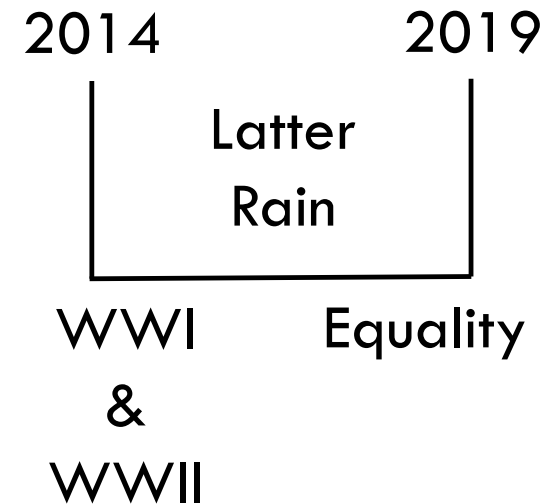
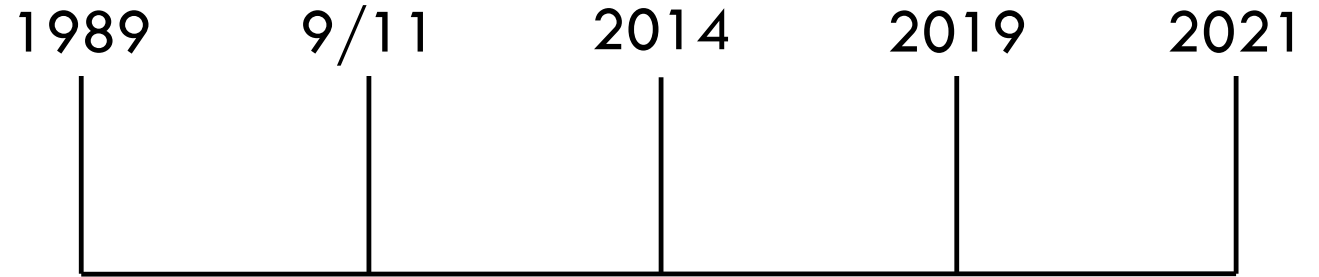

# LAYERS

For example, one of the things we looked at was the fact that there are layers in our lines. In the history of 2018 and 2019, we were on two different reform lines: the Priests' and the 144,000's (we are still on those two reform lines). On the line of the 144,000 we were/are in the Early Rain (between 9/11 and the Sunday Law); in there is Raphia and Panium (2019 and 2021). On the Priest's line we were in the Latter Rain. And for the Priests 2019 was the close of probation. These are layers- we are on more than one reform line.

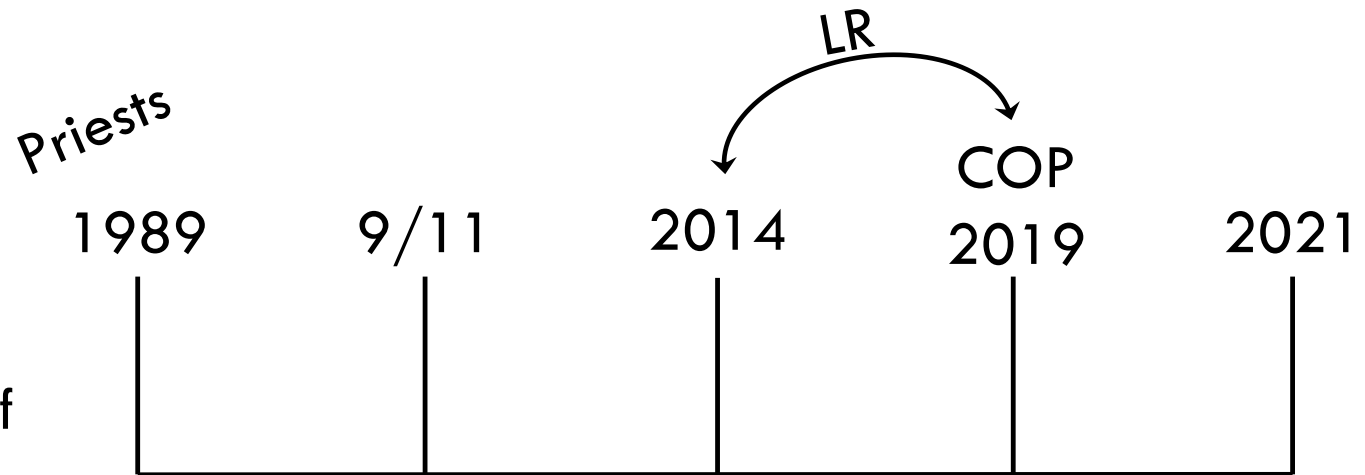
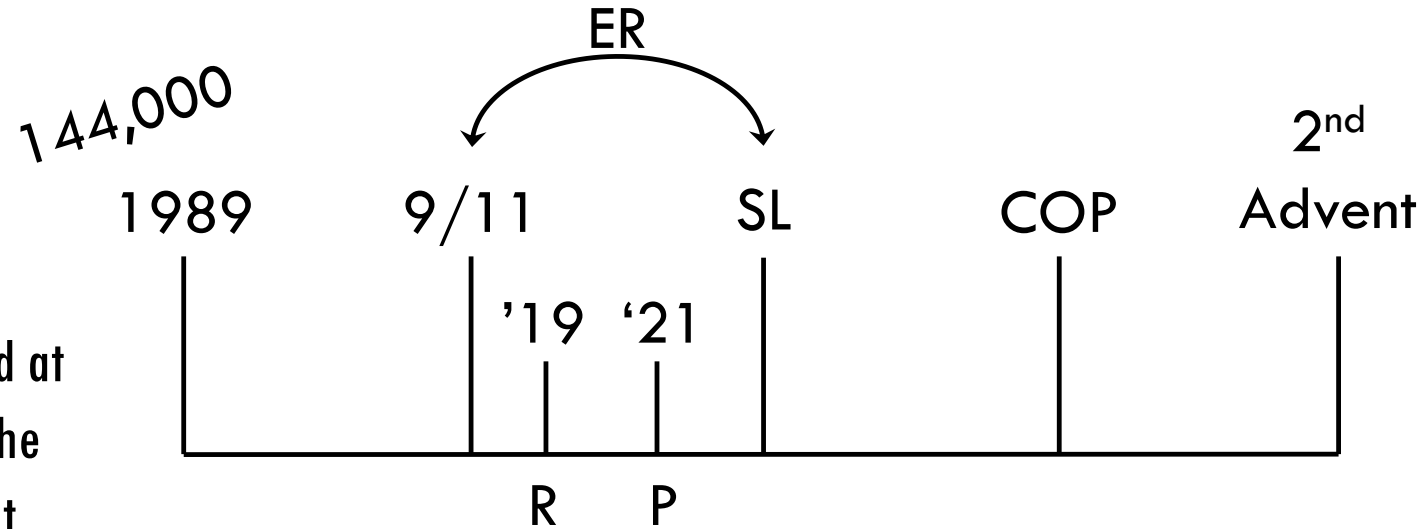

# TWO SUBJECTS

The people that left this movement (in the Midnight Cry time) struggled with two things we taught. In 2018, we taught equality and people left because of that. And in 2019, we taught about the Sunday Law. There is a triple application of prophecy on that subject: the history in 1850 (*Early Writings*) and 1888 (*the Great Controversy*).

So there are two subjects and people struggle with both: equality and the nature of the Sunday Law. We have two subjects because we're on two reform lines.

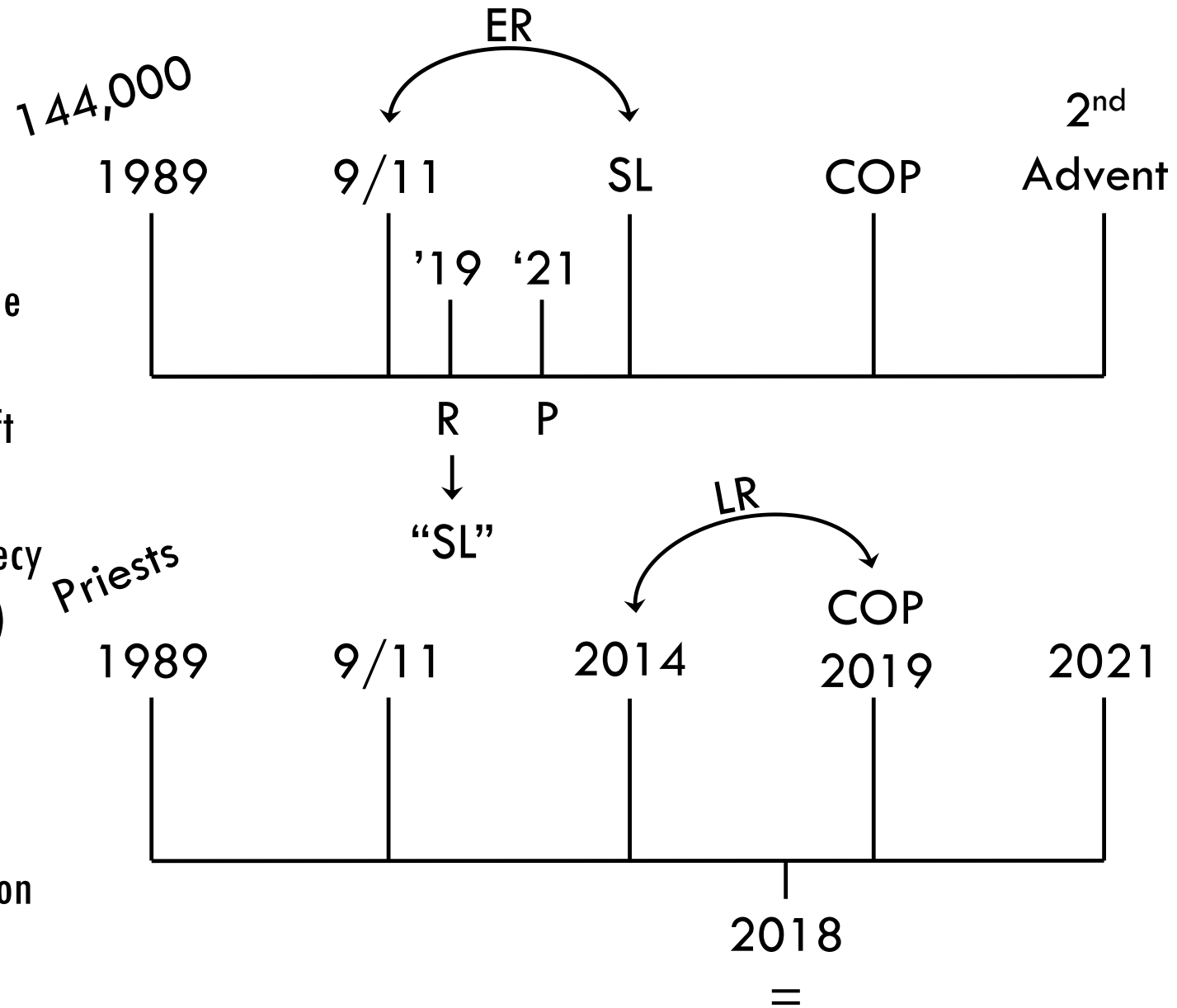

# THE MC & IOK

On the Priests' line we have the Midnight Cry or Exeter and it points to the close of probation (which was 2019). On the line of the 144,000, 2019 is Concord or the increase of knowledge of the Sunday Law. So, we have to understand the Midnight Cry: equality, and the Increase of Knowledge: the Sunday Law's nature; because we're on two different reform lines.

On the line of the Priests the message is equality, but there is also light on other subjects.

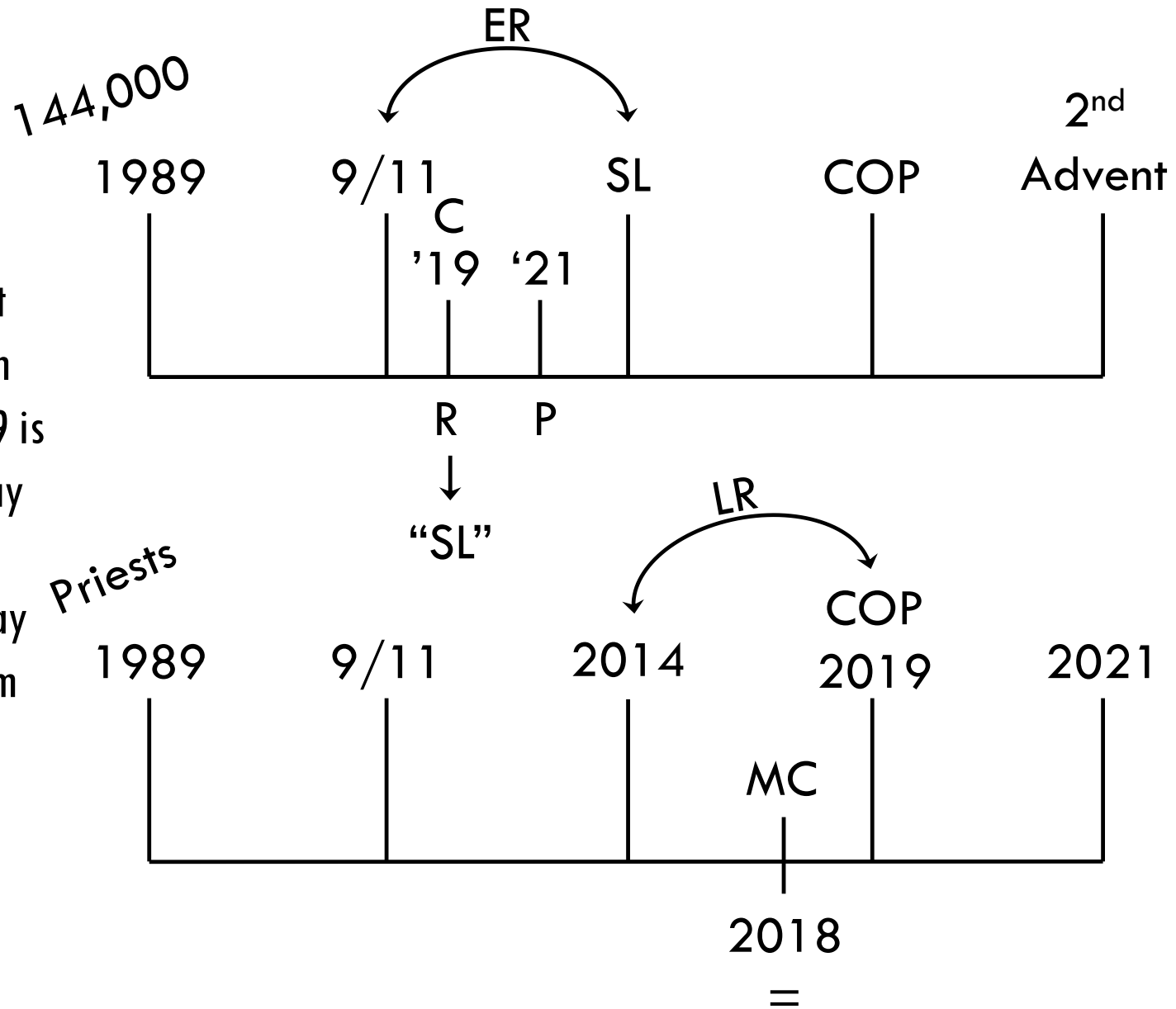

# THE PAPACY



# FATIMA

Elder Jeff's main accusation is that we've covered up the Papacy's role and made everything about the United States. When the Midnight Cry message was presented in September and October of 2018, in the School of the Prophets, the first message was Fatima. But Elder Tess had a problem, she wanted to present something about the Papacy. She presented Fatima, but she also wanted to do the line of the Counterfeit but everything had not been opened up, so she didn't do it.

Fatima





# THE COUNTERFEIT

Towards the end of the school the line made sense so Elder Tess chose to teach it last- because at the beginning it wasn't all opened up. It wasn't Elder Tess's intension to split the study of the Papacy into two parts- that's just what happened because that's how the message opened. She was forced to start with Fatima (the Papacy) and finish on the Papacy. We know that it has to be significant that the first and last presentation of the Midnight Cry were on the Papacy (that wasn't human planning).

Fatima

Counterfeit



# THE WORLD WARS

That also happened with the World Wars. World War II opened up at the beginning of the Midnight Cry, and World War I opened up at the end. That wasn't human planning either.

World War I

World War II



# THE PAPACY & THE KING OF THE NORTH

While the message between 2014 and 2019 was about the King of the North and the King of the South, there is a connection between the King of the North and the Papacy. We can see that in 1989. When we understand the King of the North and the King of the South we also get a little light on other subjects- and one of those is the Papacy.

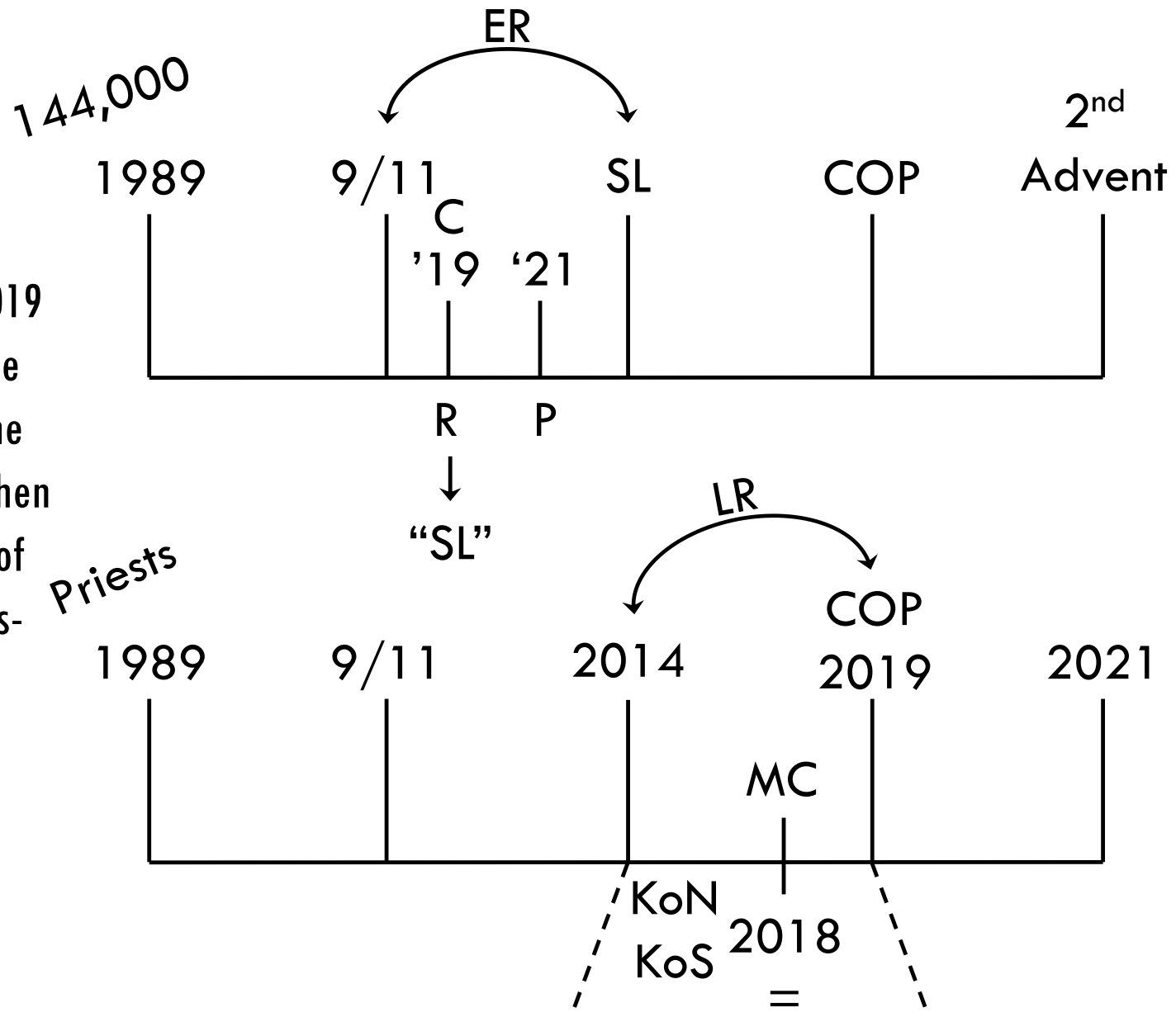

# THE PAPACY & THE 144,000'S LINE

On the 144,000's line 2019 is the increase of knowledge of the Sunday Law. Let's expand that dispensation and look at the repeating pattern. 9/11 is Boston, there a message was unsealed. Then, there was an increase of knowledge and 2019 is Concord. Next, the message is formalized at Panium which is in 2021. All of that is preparation for the test: the Sunday Law. That's the dispensation of the 144,000 that we are currently in. So we can see that in 2019 it is important that we understand the Papacy, because the Papacy is at the Sunday Law.

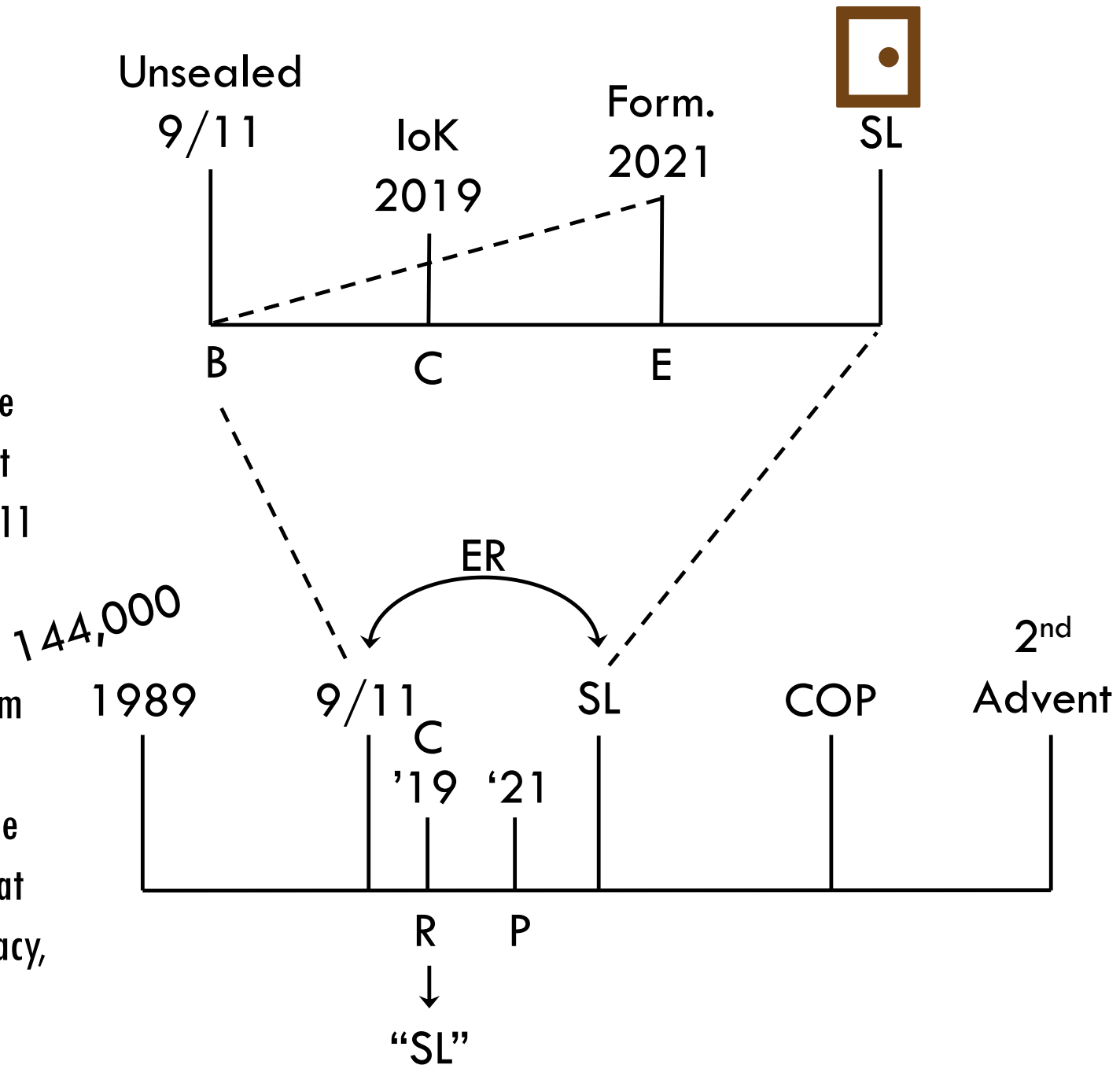

# AT THE SUNDAY LAW

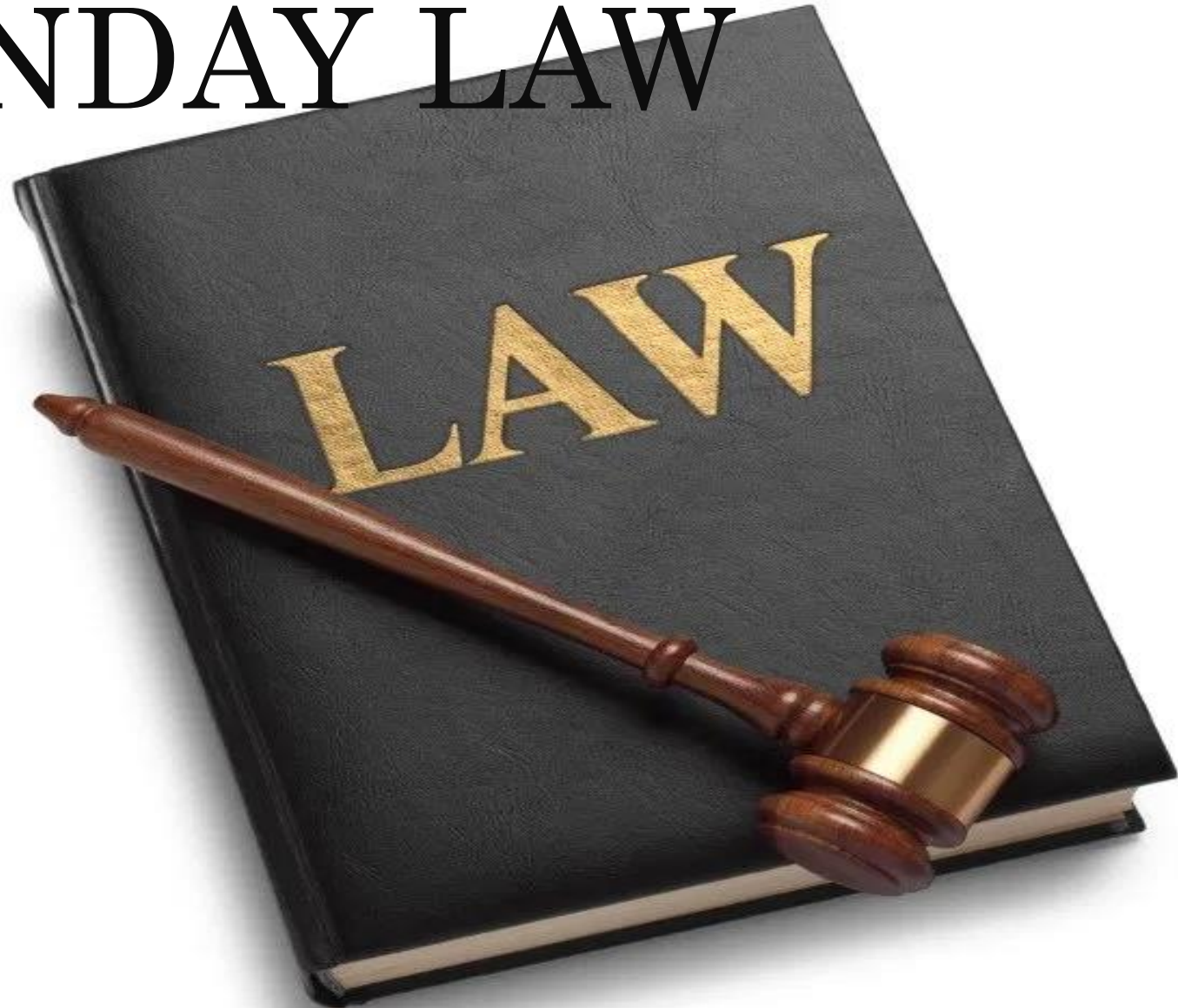

# EVENTS AT THE SL

What do we know happens at the Sunday Law?

- The resurrection, or the healing of the deadly wound, of the Papacy.

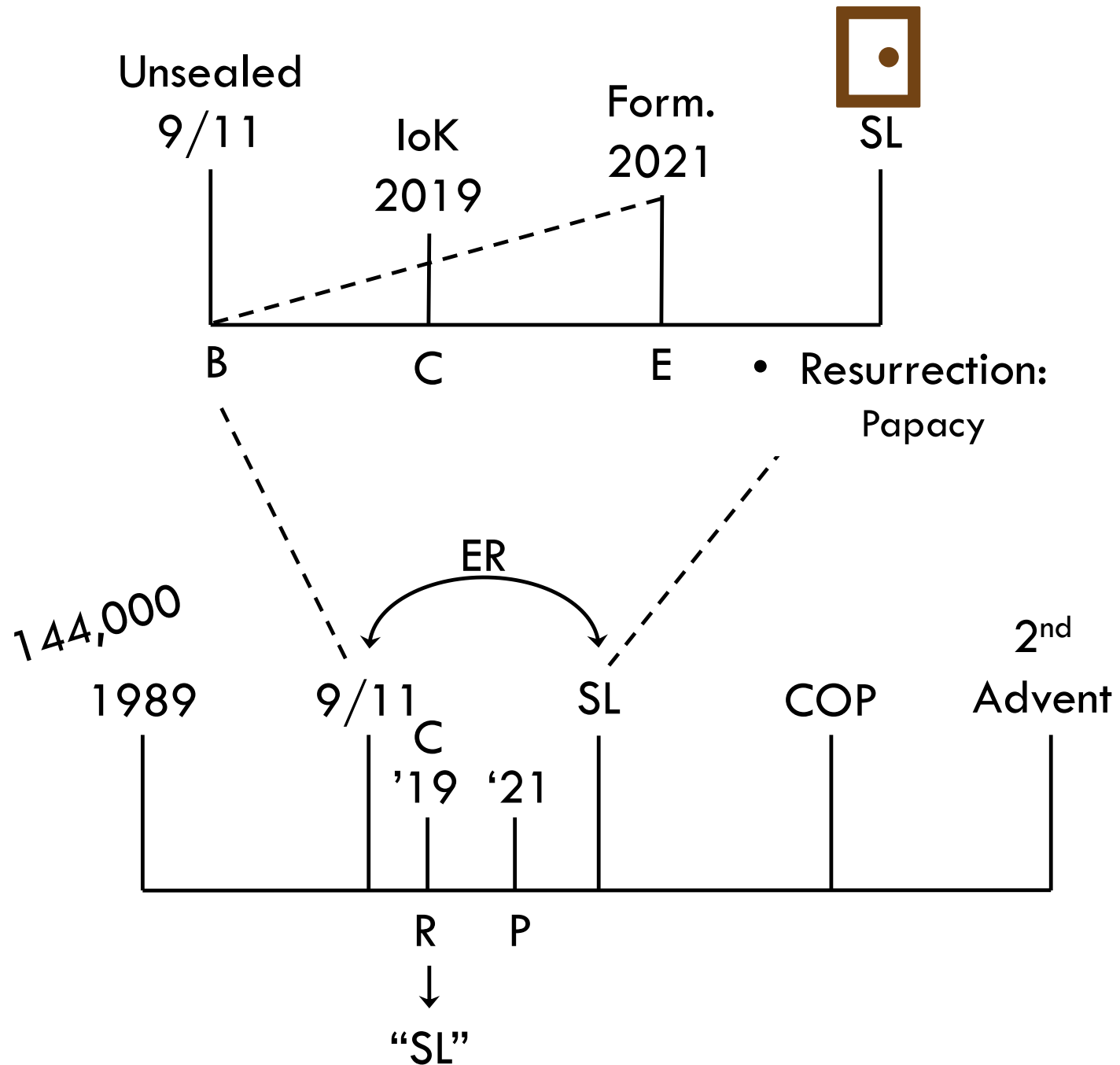

# EVENTS AT THE SL

What other external events happen there?

- The seventh kingdom is there. It is the United States in charge of other countries; we know we are in the seventh kingdom when the US speaks. Speaking means passing the “Sunday law” - it’s not really a “Sunday” law though, it’s discrimination against minorities. That’s when the Republican horn is broken. We see that from 1850 and slavery (which is discrimination). This let’s us see that equality is actually a subject for both the Priests and the 144,000, which is why it’s opening up this whole history.

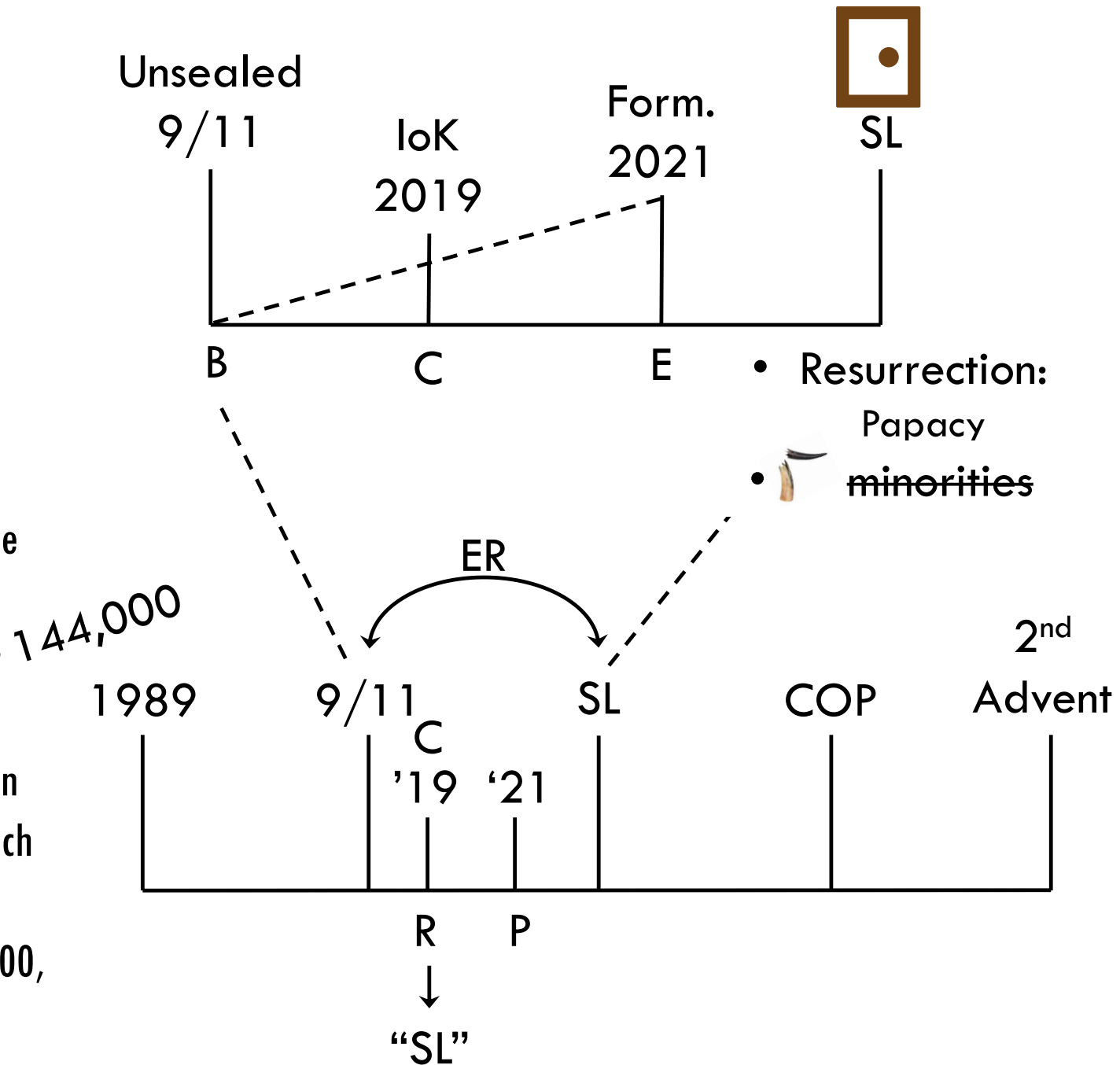

# EVENTS AT THE SL

What else happens at the Sunday Law?

- Another external event is shipwreck; so we know that discrimination (which is against the Constitution and causes the breaking of the USA's horn) will have something to do with the Seventh-day Adventist church, because both institutions are shipwrecked at the Sunday Law.

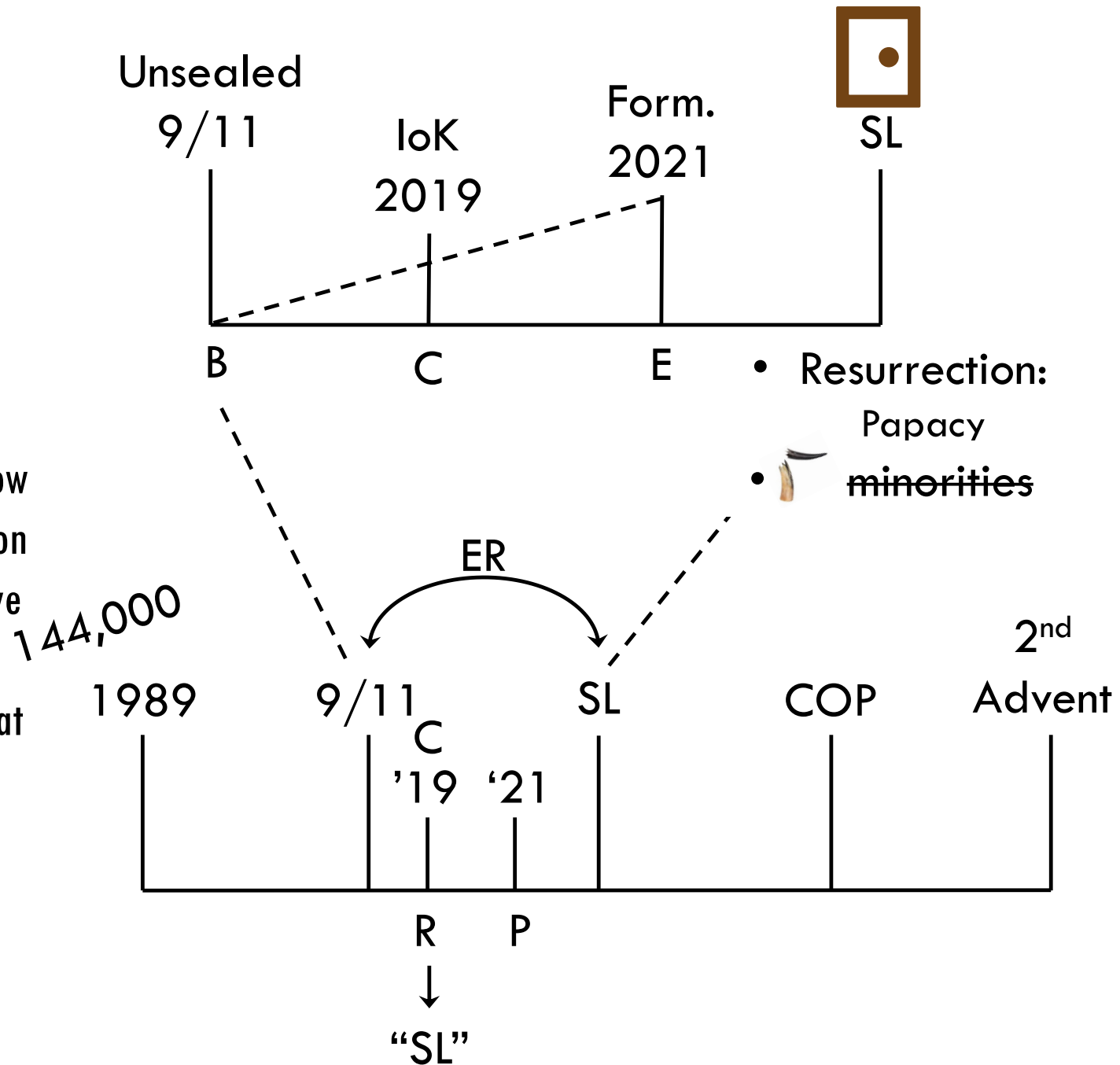



# EVENTS AT THE SL

- Another external event is Islam.

We can see that we are in the increase of knowledge of the Sunday Law- the only truth is not the King of the North and the King of the South and the World Wars; there are other layers. And because we are in this time we need to understand the Papacy (2018/2019), the nature of the Sunday Law (2019), and how the Millerites understood Islam (2019). So we are here (in 2020, right after the loK) and we should understand all of these things.

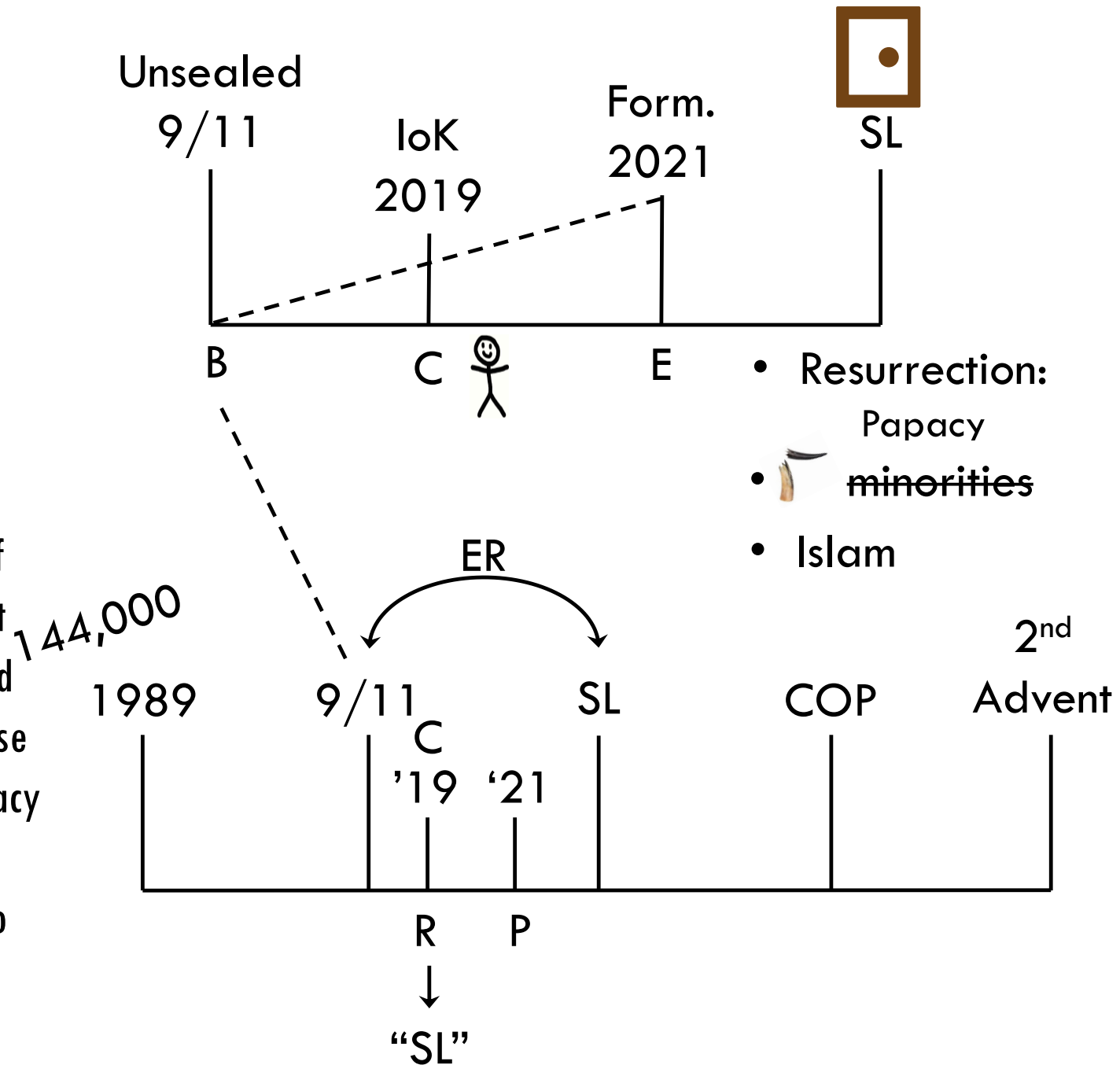

# THE MC MESSAGE

When Elder Tess says the King of the North and the King of the South she is being specific to the beginning of the Midnight Cry message for the Priests. That, which developed into equality, was the subject of our Latter rain. But we still got light on the Papacy. Even the Third Diadochi War, which is mainly about the KoN and the KoS has details about the Papacy and Islam. All of these symbols are connected.

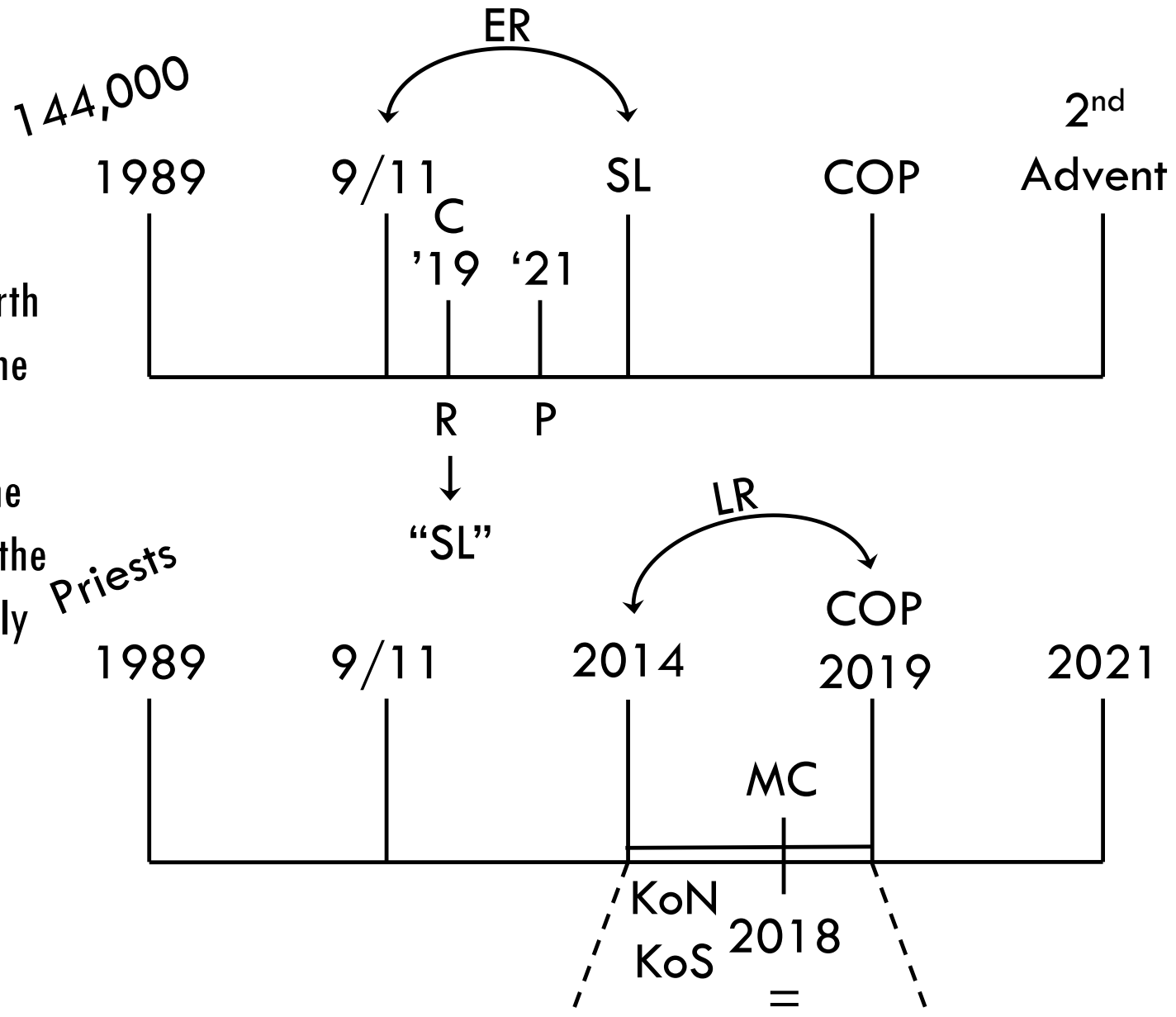

# LOOSE ENDS PART 2



# RESURRECTION

Seeing that those subjects are connected we were able to compare and contrast what “resurrection” means. How we know the Papacy (the KoN) will resurrect shows us what resurrection looks like for the King of the South. Resurrection is taking back what you lost when you died. The Papacy resurrects when it recovers what it lost in 1798; the King of the South does the same, but from 1989. The Papacy will resurrect at the Sunday Law, but it will also have to fight (from Panium to then) to get that power back. Russia (the KoS) resurrected at Raphia/2019 and it had fought the United States to get that power back just like the Papacy will have to do.

# 2 WITNESSES

Another thing we saw was how there were two witnesses for every step (truth) in the development of the Midnight Cry message. There were two witnesses for:

- 273 (Acts 17 and Numbers 3)
- bringing us to WW II (Counterfeit and Pyrrhus' time)
- the 2<sup>nd</sup> half of our line- WW III (Pyrrhus' Omega line and WW II)
- the 1<sup>st</sup> half our line- WW III (3<sup>rd</sup> Diadochi War and WW I)

# EXTERNAL EVENTS

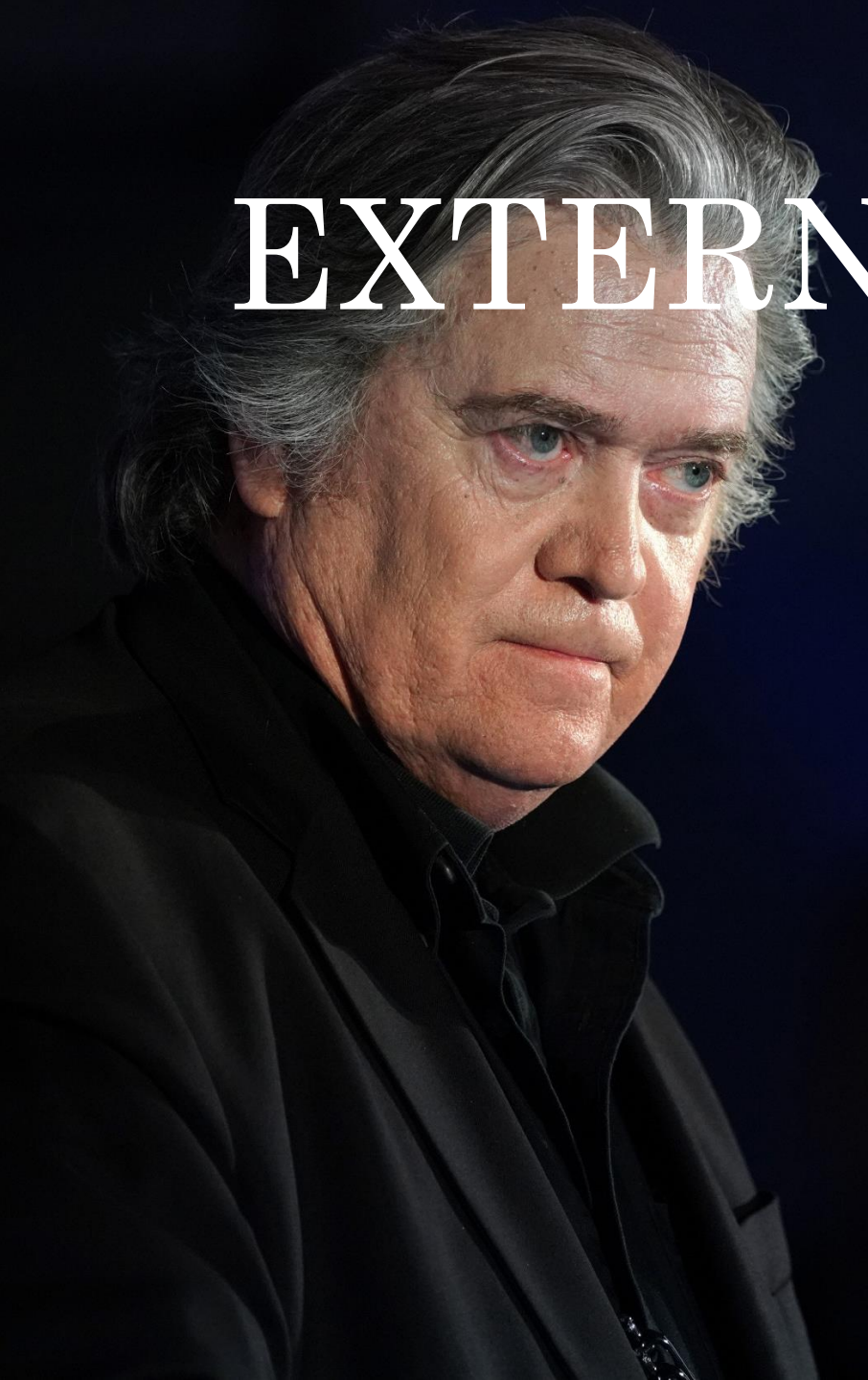

# WW3 ⇒ EQUALITY

So how did the King of the North and the King of the South lead this movement to equality? The KoN and the KoS have to do with geography, and they are polar opposites. We know that the King of the North is church over state- so the King of the South is state over church (these can be compared to marriage). These two models brought us to equality; there is inequality in both the KoN and the KoS. So by studying the World Wars (WW III) in the Latter rain of the Priests (2014 to 2019) we came to a study of equality.

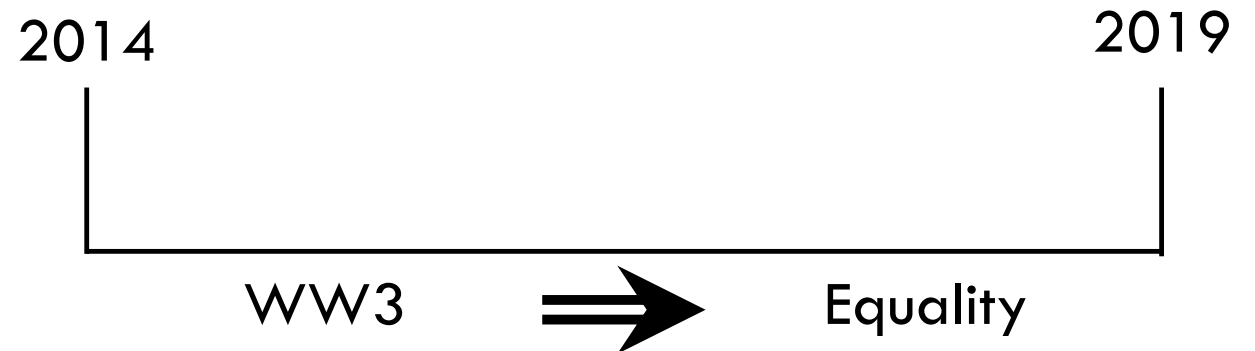

# EXTERNAL EVENTS ABOUT EQUALITY

What are some external events in that history? Equality was a testing message for Priests, Levites, and Nethinims. We should see that test in external events because they don't have the prophetic message we have. So how were they tested on equality from 2014 – 2019?

- In 2014 there are 3 people: Steve Bannon, Jeff Session, and, Stephen Miller; they started working together to overthrow the American establishment.

1. Bannon
2. Sessions
3. Miller

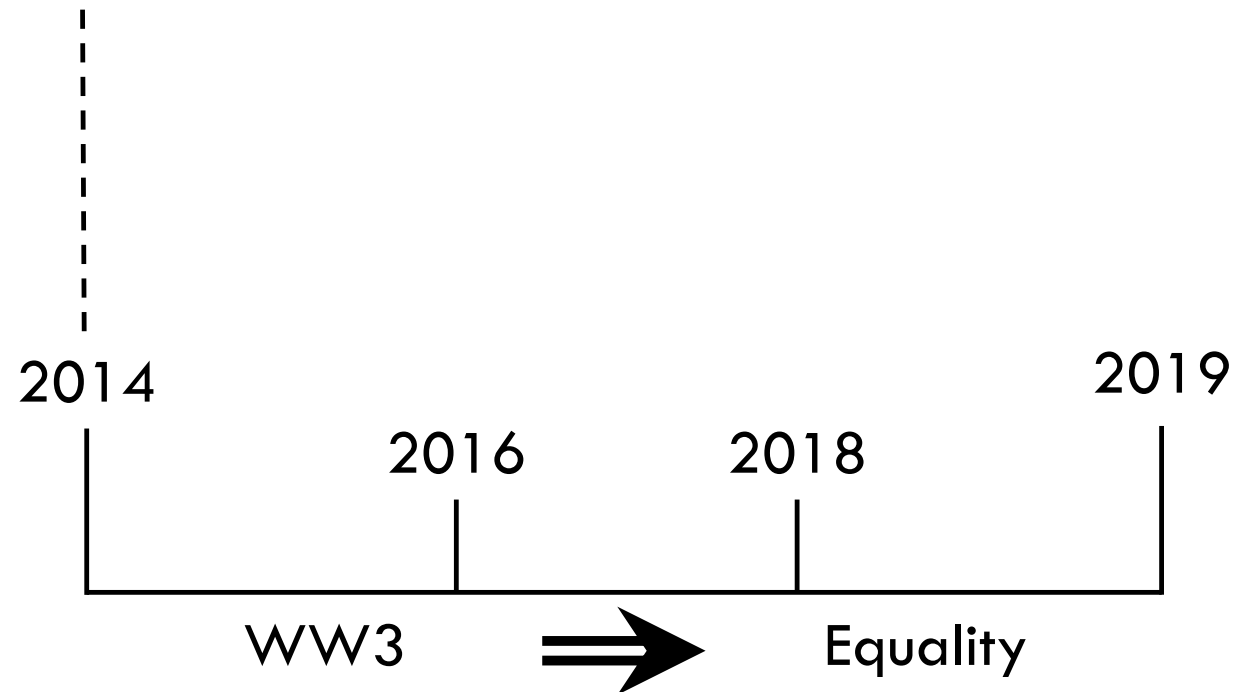



# EXTERNAL EVENTS ABOUT EQUALITY

- In 2015 Obama got more rights for gay marriage.
- In 2016 Donald Trump got elected. He fought against Barack Obama and Hillary Clinton (and both of them represented minorities).
- In 2017 there were laws restricting the rights of homosexuals. In 2017, as well, the Me Too movement hit the FOX news network with what happened to Megyn Kelly. Also DACA was overturned. DACA was a policy that Obama made that protected young immigrants called dreamers.

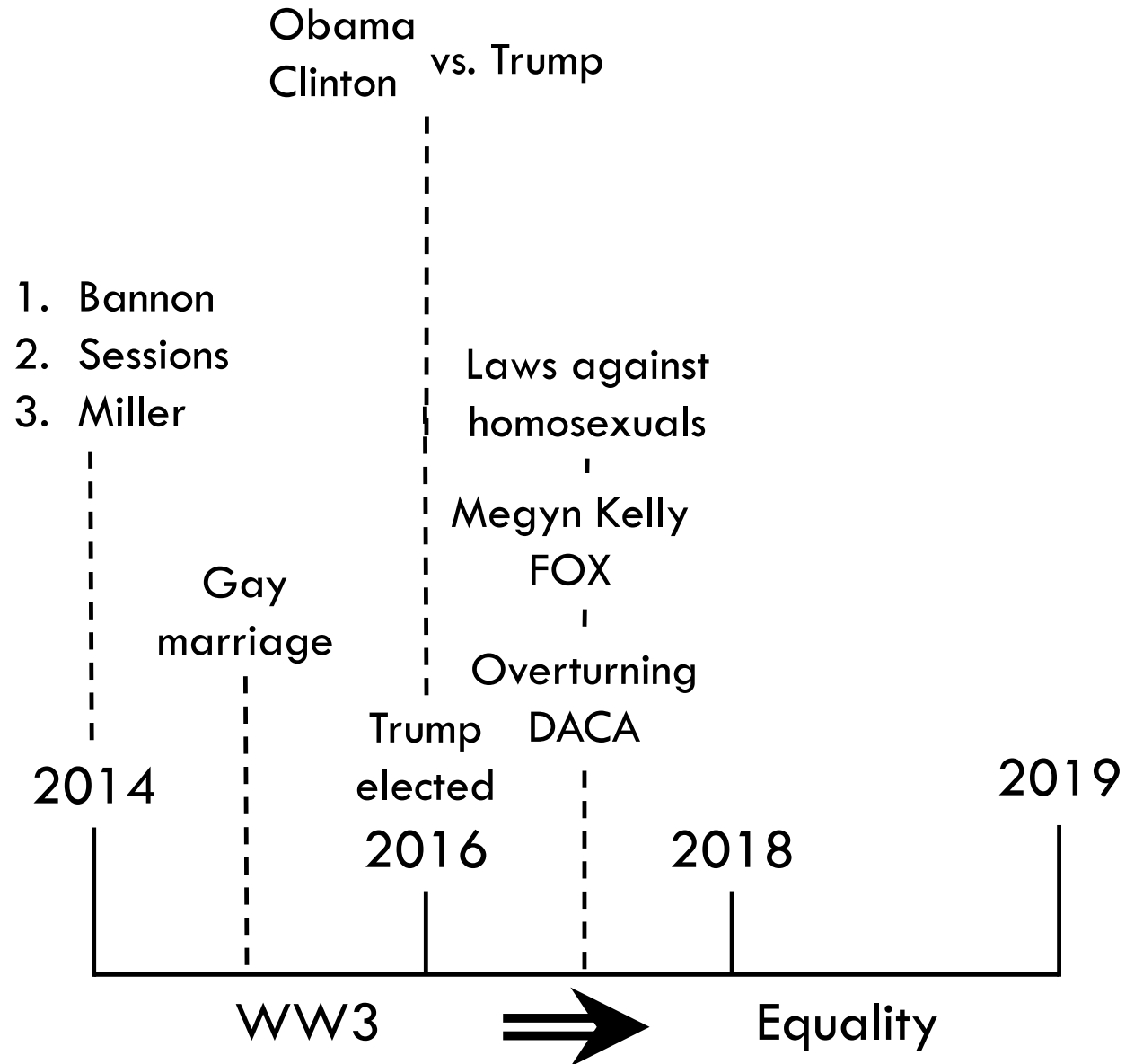

# EXTERNAL EVENTS ABOUT EQUALITY

- In 2018 Alexandria Ocasio-Cortez, Rashida Tlaib, and Ilhan Omar were elected to the House of Representatives. They are from minorities that are discriminated against and they became the most significant visible opponents of the far right.
- There is a crisis on the Southern border of the US and Trump calls it an “invasion” of immigrants. Stephen Miller made a plan in 2018 to make it very hard for immigrants- he wanted to stop them from coming. He put things in place like separating families. A.O.C. has called the places where immigrants are kept concentration camps.

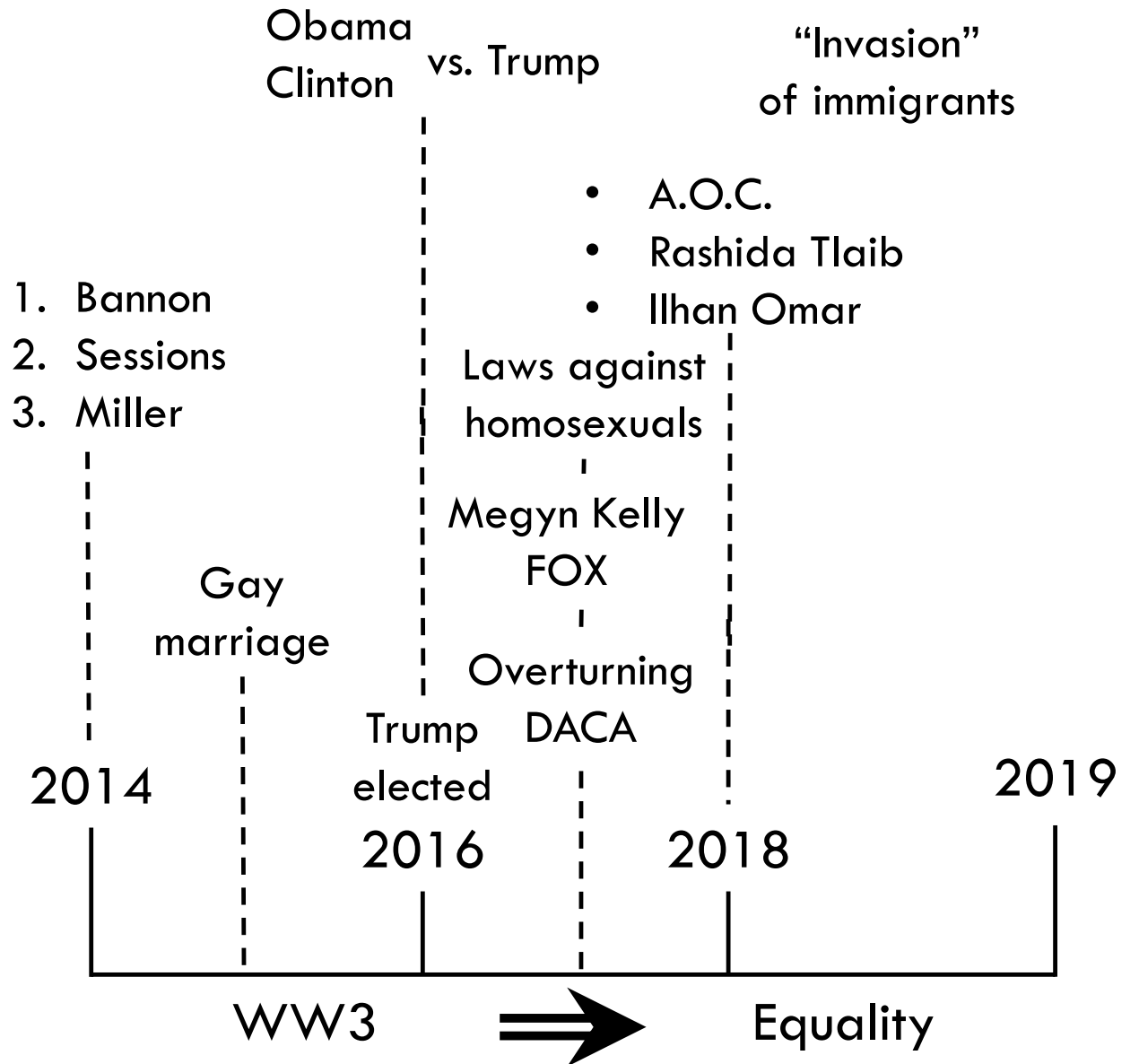

# EXTERNAL EVENTS ABOUT EQUALITY

- Around 2018 there were also laws against abortion.
- This year Trump got more travel bans passed, this time mainly for African countries. His first travel ban was in 2017 and it was mainly for largely Muslim countries.
- Trump also says many mean things about women, including Megyn Kelly.

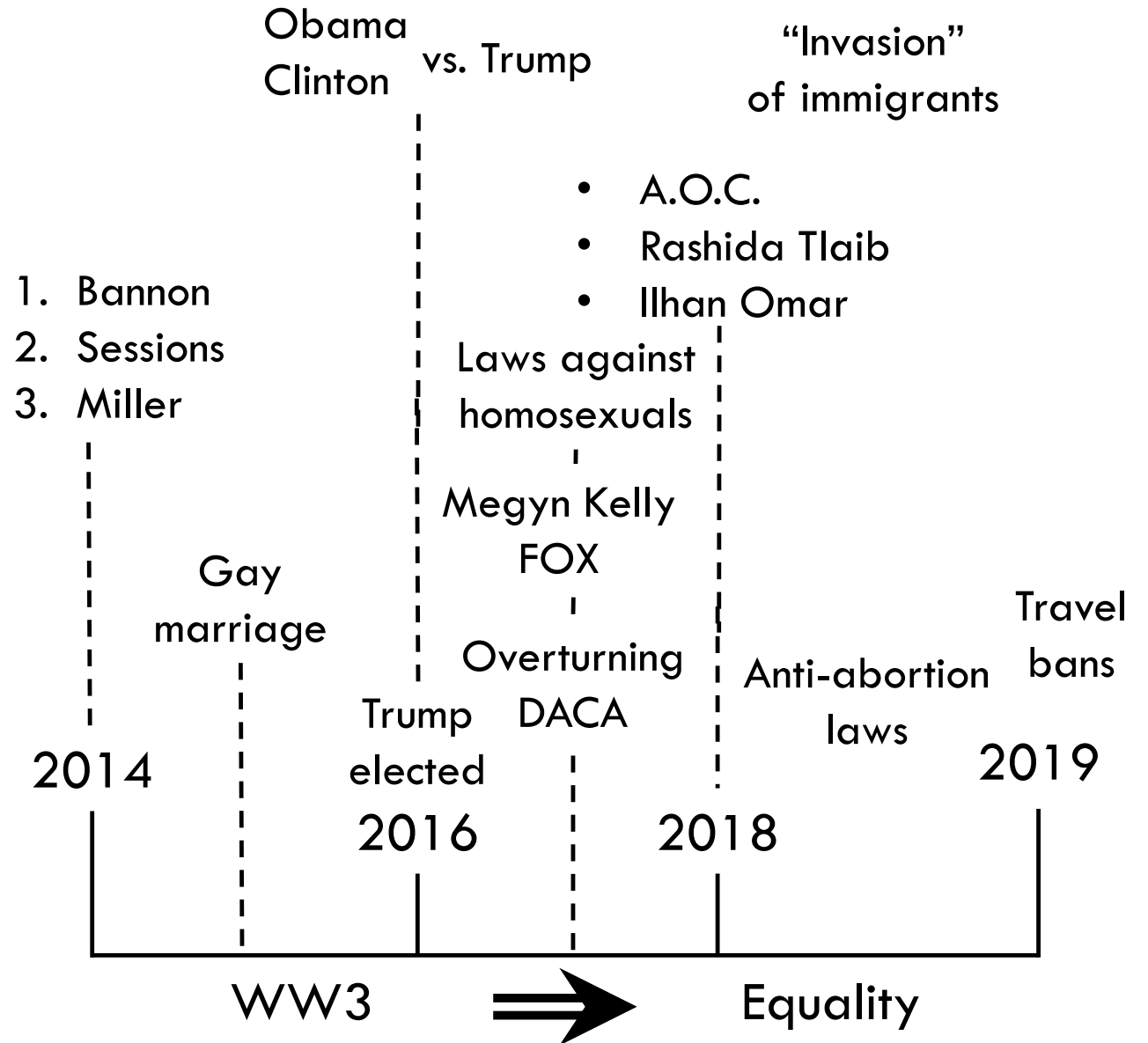

# EXTERNAL EVENTS ABOUT EQUALITY

This is just a little of what has happened. Everything started with Steve Bannon in 2014. What Bannon, Sessions, and Miller started to do was overthrow the court system so they could get these things done.

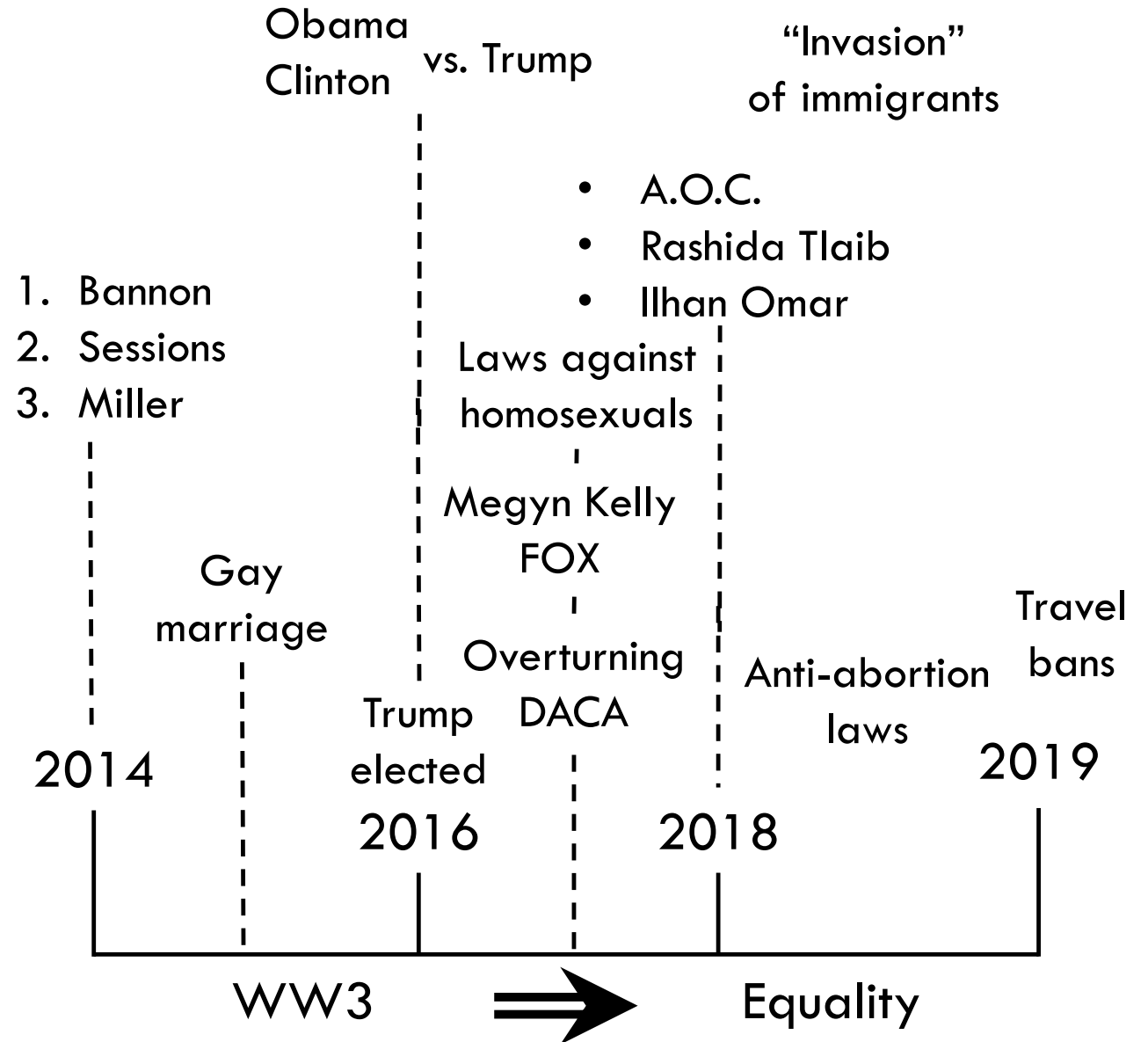

# THE SUNDAY “LAW”



# IS THE SL A LAW?

At the Sunday Law waymark on the line of the 144,000 (which actually isn't a 'Sunday' law) is there a law passed? Why shouldn't there be one? Just because its not about Sabbath and Sunday doesn't mean there will be no law; it's about equality- so it can just be a law about equality. You can only control people through laws. We would say, in the past, that Trump didn't like keeping the Sabbath so he would make a law that would stop people from keeping the Sabbath. Now Trump just doesn't like equality- there should still be a law.

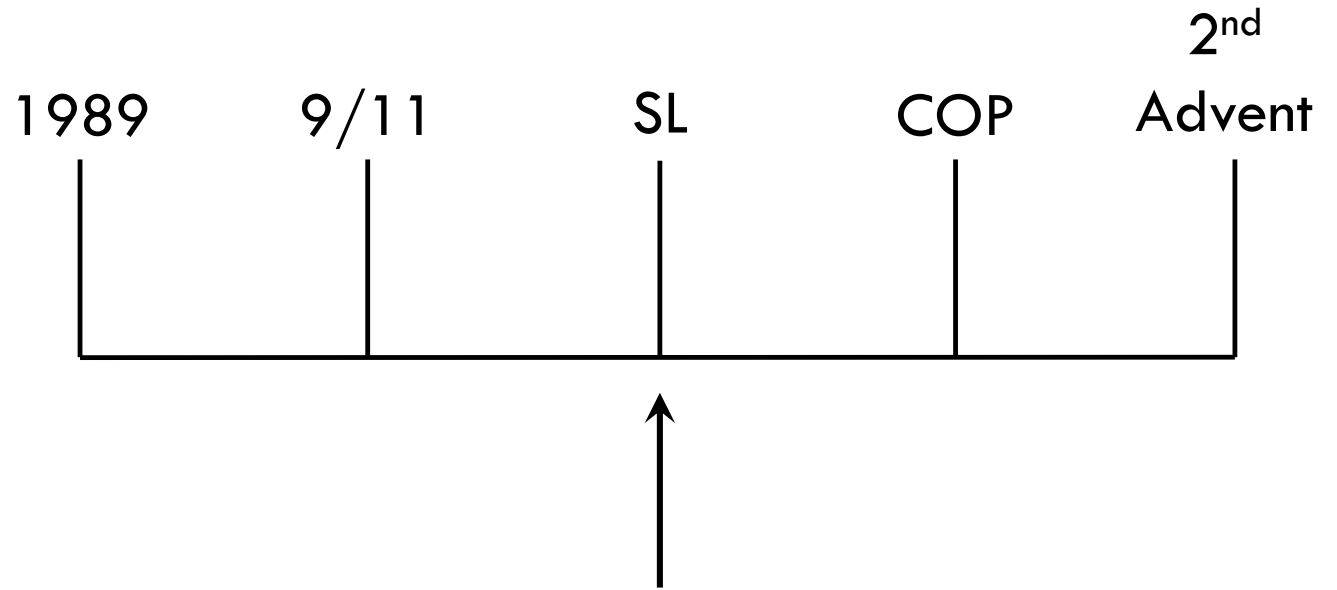

# IS THE SL A LAW?

Fake news can't replace a law, it can't make you do anything. It might trick other people into doing something- like keeping Sunday- but it won't ever convince us. Trump doesn't even particularly care about Sabbath or Sunday. The state can only persecute people if there is a law.

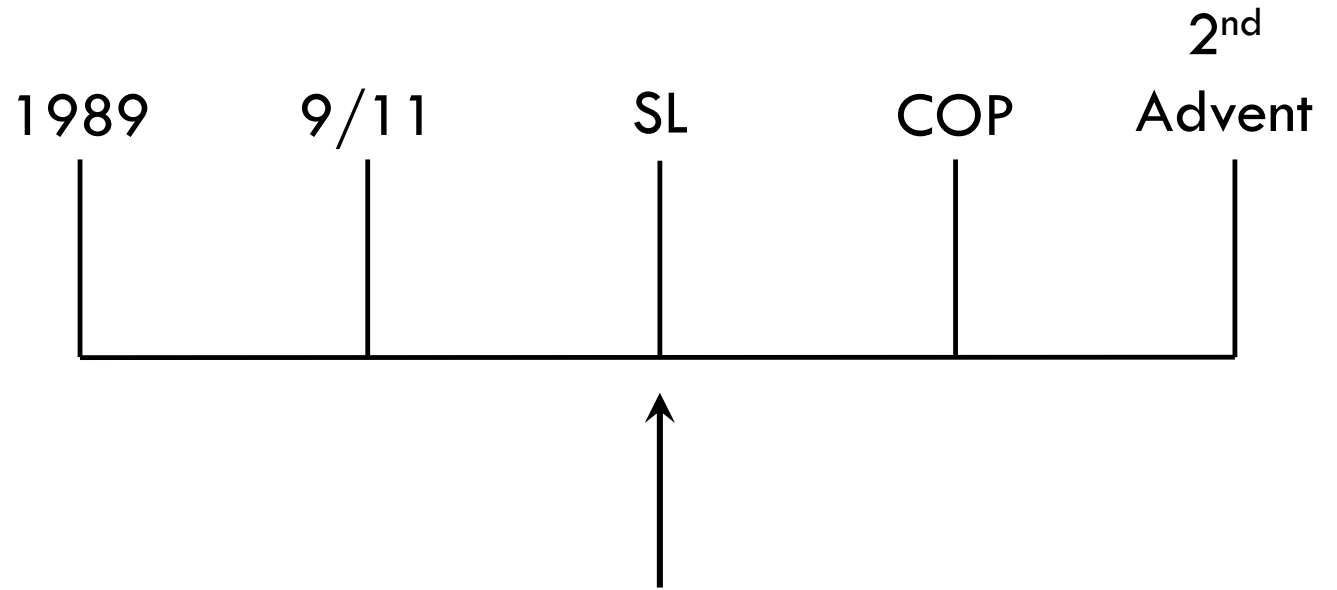

# IS THE SL A LAW?

## 1850 AND 1888

In 1888 some Protestants wanted everyone to keep Sunday, so they tried to make that a law. In 1888 there was an (attempted) law. In 1850 you have the issue of slavery. Slave owners could have tried to use things like conspiracy theories and fake news to try to convince people to practice slavery, but they couldn't force them; until the Fugitive Slave Act- a law. So we can't say it's not a law because it's not about slavery. You have a triple application of prophecy (1850 + 1888 = our SL waymark). Those two events in Millerite history were laws so in our time it must be a law too. All three laws are important.

1850 → Slavery - LAW

+ 1888 → Sunday - LAW

---

“SL” - LAW



# HOW LAWS ARE PASSED

What does the United States do to pass a law?

First, a bill must be passed in both houses of Congress. Then, the president must sign it into law, but it could still fail because you need the Judicial system (the judges) to agree with your law because courts have a power called *Judicial review* where they can say a law is unconstitutional and invalidate it. For example, under President Obama you could not have introduced a travel ban into the Supreme Court- it would not have allowed that. So, to get all of these discriminatory laws passed you first have to change the courts.

# COURTS AND JUDGES



# WHAT MITCH McCONNELL DID

Donald Trump was given a gift. In 2014, the Republicans took control of the Senate and enlarged their majority in the House of Representatives. Mitch McConnell became the Senate majority leader and he began blocking President Obama from appointing any more judges, when that was his job. McConnell even blocked Obama from appointing another judge to the Supreme Court when there was a vacancy. In the American Judicial system Federal judges serve for life, so they are important.

# THE US FEDERAL COURT STRUCTURE

1<sup>st</sup> level:  
Supreme Court

1

2<sup>nd</sup> level: Courts  
of Appeals/  
Circuit Courts

13

3<sup>rd</sup> level: District  
Courts

94

# JUDGES APPOINTED

- George W. Bush appointed 2 Supreme Court judges and 62 Circuit Court judges in 2 terms.
- Obama, in 2 terms, appointed 2 Supreme Court judges; as well as 55 Circuit Court judges.

|                 | Circuit Courts | Supreme Court |
|-----------------|----------------|---------------|
| Bush (8 years)  | 62             | 2             |
| Obama (8 years) | 55             | 2             |
|                 |                |               |

# JUDGES APPOINTED

Then, as we have seen, in 2014 Mitch McConnell stopped Obama from appointing any more judges. He says that that was the most significant political thing he has ever done. And Donald Trump says that appointing judges is the most important thing he has ever done as president. Both Mitch McConnell and Donald Trump know how significant appointing judges is.

|                        | Circuit Courts | Supreme Court |
|------------------------|----------------|---------------|
| <b>Bush (8 years)</b>  | 62             | 2             |
| <b>Obama (8 years)</b> | 55             | 2             |
|                        |                |               |

# JUDGES APPOINTED

So Trump, in 4 years- not 8 like Bush and Obama, has appointed almost the same number of judges as they did. He appointed 2 Supreme Court judges and 51 Circuit Court judges. Also the judges he appointed are very conservative. The Supreme Court and the Circuit Courts have gone from liberal or balanced to strongly conservative. And the judges, who are conservative, are in that position for the rest of their life.

|                 | Circuit Courts | Supreme Court |
|-----------------|----------------|---------------|
| Bush (8 years)  | 62             | 2             |
| Obama (8 years) | 55             | 2             |
| Trump (4 years) | 51             | 2             |

# THE BALANCE

The Supreme Court has 9 judges (since 1869). And traditionally there'd be 4 conservative judges, 4 liberals, and 1 who was in the middle. This balance had lasted for a while- until Trump came. Now the Supreme Court has 5 conservatives and 4 liberals. There are lots of cases coming up this year; and many are about women's, homosexuals', immigrants', and black peoples' rights. The Court now votes 5/4: Trump has made it conservative.

|                 | Circuit Courts | Supreme Court |
|-----------------|----------------|---------------|
| Bush (8 years)  | 62             | 2             |
| Obama (8 years) | 55             | 2             |
| Trump (4 years) | 51             | 2             |

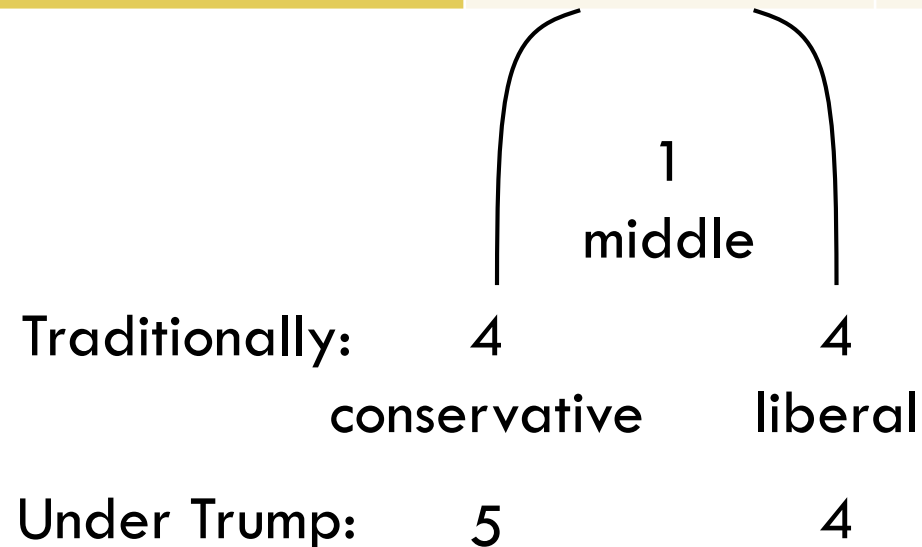



# RUTH BADER GINSBURG



# RUTH BADER GINSBURG

Who in the Supreme Court is hanging on for dear life? Ruth Bader Ginsburg. She is the second woman elected on the Supreme Court. How old is she? 87. And how many times has she almost died (or been really sick)? 6. She has had cancer 4 times, has had to get an artery propped open, and has fractured 3 ribs. She is currently (as of January) free of cancer though.

|                 | Circuit Courts | Supreme Court |
|-----------------|----------------|---------------|
| Bush (8 years)  | 62             | 2             |
| Obama (8 years) | 55             | 2             |
| Trump (4 years) | 51             | 2             |

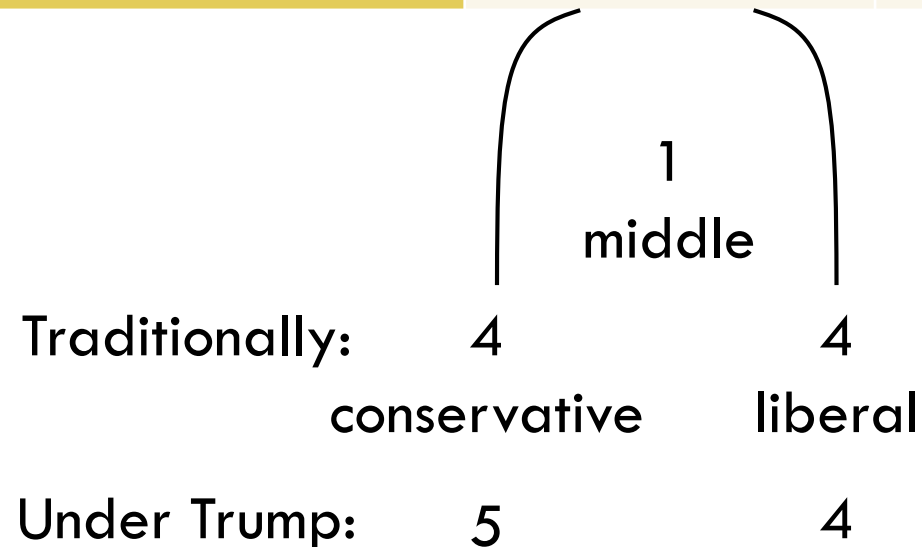

- Ruth Bader Ginsburg

# RUTH BADER GINSBURG

But she doesn't want to die, not just because she doesn't want to die, but also because she knows that if she dies Trump will appoint another conservative judge to the Supreme Court. Then the court will be 6/3 and nothing liberal will ever pass. So many people are determined to keep her alive (she is also determined to stay alive) at least until the presidential election in 2020.

|                 | Circuit Courts | Supreme Court |
|-----------------|----------------|---------------|
| Bush (8 years)  | 62             | 2             |
| Obama (8 years) | 55             | 2             |
| Trump (4 years) | 51             | 2             |

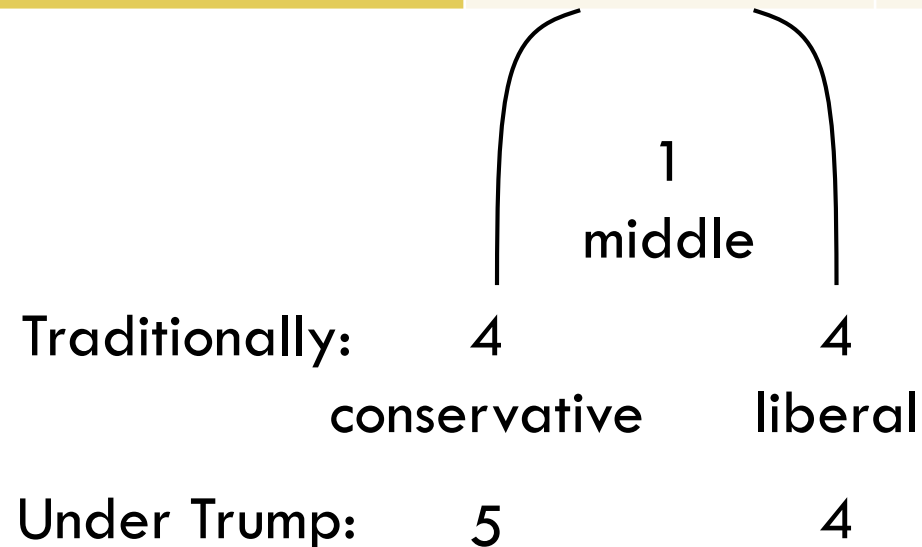

- Ruth Bader Ginsburg

# RUTH BADER GINSBURG

They think that if they can get Trump out of office then they can get a liberal judge appointed after she dies, and save the Supreme Court. But if Ruth Bader Ginsburg dies before the 2020 election Trump will appoint another judge who will stay in that position for the rest of their life- and he has appointed “young” judges (compared to Obama’s judges).

|                 | Circuit Courts | Supreme Court |
|-----------------|----------------|---------------|
| Bush (8 years)  | 62             | 2             |
| Obama (8 years) | 55             | 2             |
| Trump (4 years) | 51             | 2             |

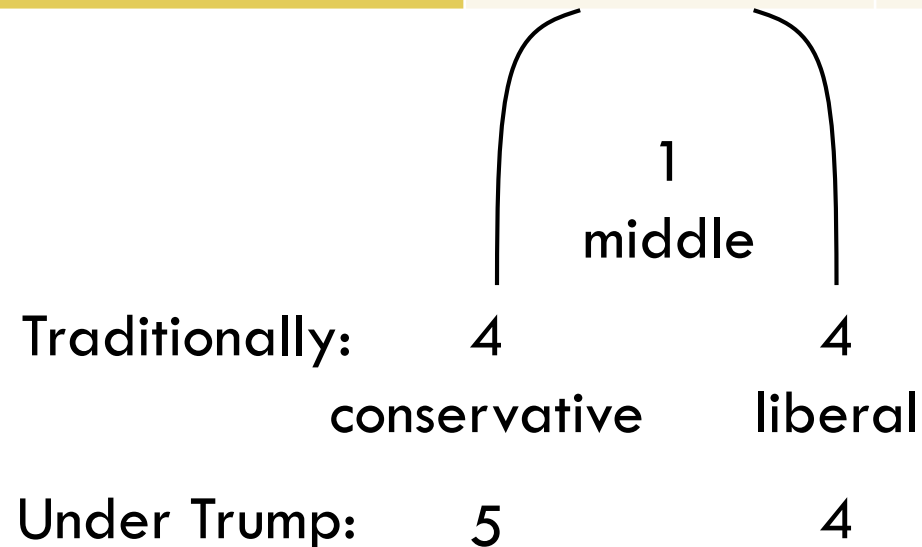

- Ruth Bader Ginsburg



# A CAKE

For example: a homosexual goes into a bakery and requests a wedding cake. The baker refuses saying that they don't cook for those kinds of people. There are two interpretations of that incident. A conservative would say that it's against their religious freedom to bake the cake. On the other hand a liberal would say that the homosexual was discriminated against; a Christian doesn't have to sanction their wedding, all they have to do is bake them a cake like they would anyone else- just show equality.

# SLAVERY

This example is like slavery. In the time of slavery, conservatives would argue that it was against their religious ideas to not own slaves. Liberals would argue that the slaves, not the slave owners, were being discriminated against. Conservatives would say that the Bible says races shouldn't mix and the Glorious Land should have slaves. That became a debate over who's rights were being violated.

# CIVIL RIGHTS

In the Civil Rights Movement time there was the same dynamic. You have an African American who goes into a bakery and asks for a birthday cake, but the owner refuses saying that serving them would be against their religious convictions. We discussed that that is similar to what happened in the schools of the time. It was against Jerry Falwell's religious ideas to educate an African American.

Civil Rights  
Movement

African  
American  
↓  
A cake  
request

Protestant  
owner  
↓  
"No"-  
religious  
convictions



# CIVIL RIGHTS: A CAKE

So, back to the cake example: the African American asks for a cake and the Protestant owner says no because of their religious views. Now, is it against the Constitution to tell the Protestant owner that they cannot deny someone service for that reason? That was the argument around segregation. The Protestants were saying that they were the victims, that they were being persecuted, and that de-segregation would violate their religious convictions. They said no one should be able to force them to bake an African American a cake.

Civil Rights  
Movement

African  
American  
↓  
A cake  
request

Protestant  
owner  
↓  
“No”-  
religious  
convictions

# GAY RIGHTS: A CAKE

Now the story is about a homosexual who is getting married. The Protestant says that they don't bake cakes for homosexuals- it's against their religious conviction. The argument ends up becoming who's the victim- who's being discriminated against. A conservative judge would say the Protestant owner is being discriminated against; a liberal judge would say that the person being discriminated against is the homosexual. In other situations a liberal judge would also vote in favor of an African American, a woman, an immigrant, or a slave. That's how there's been two sides since the beginning.

Civil Rights  
Movement

African  
American

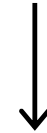

A cake  
request



homosexual

Protestant  
owner



"No"-  
religious  
convictions



Protestant  
owner

# COURT CASES THIS YEAR

This year, there are many court cases coming up, and they have been building since 2014. And from 2014 to 2019 the Republicans have taken over the Supreme Court and the Circuit Courts; now they're conservative. This year those courts are faced with cases about discrimination dealing with these three groups.

# THREE MOVEMENTS

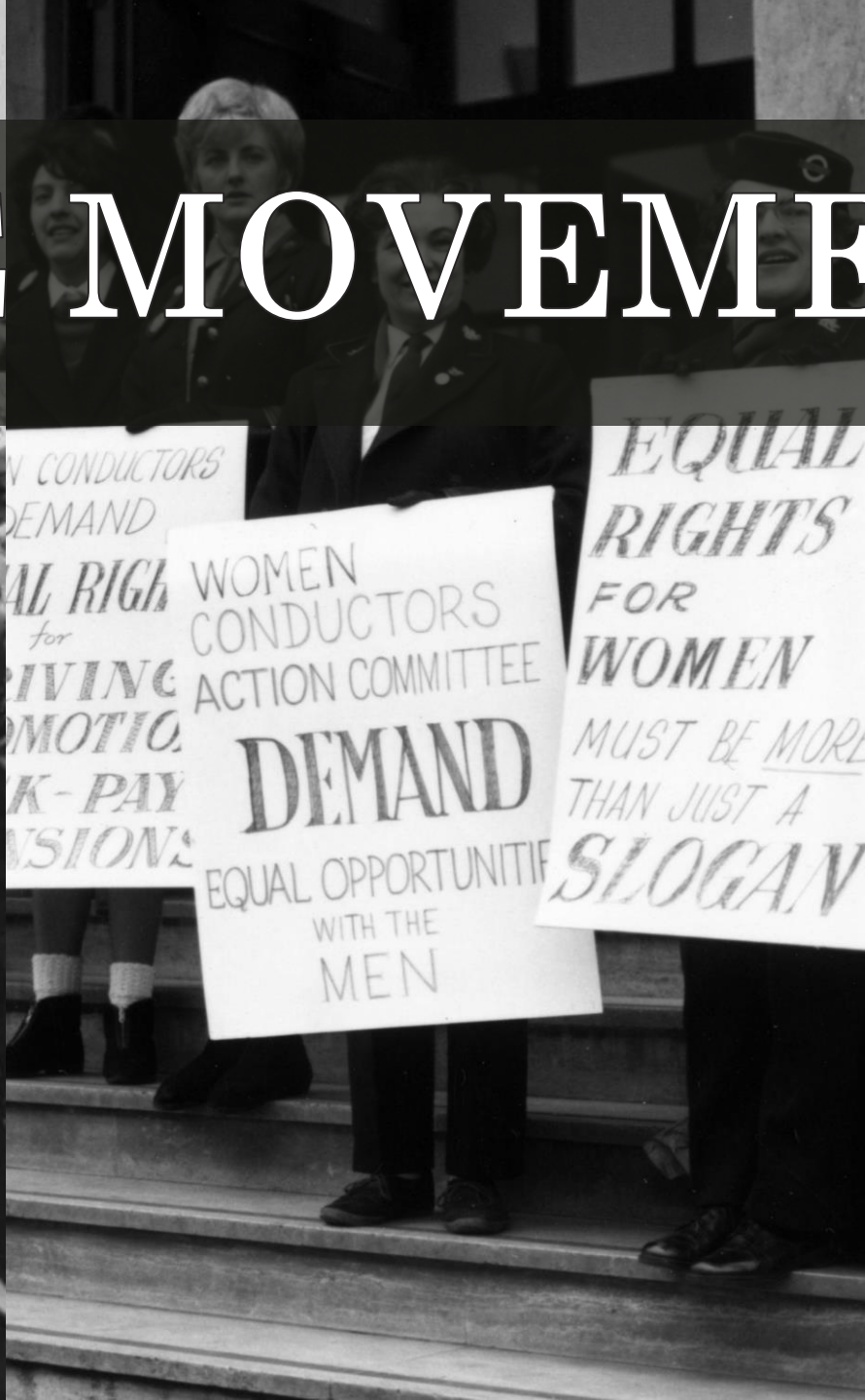

# THE 3 GROUPS

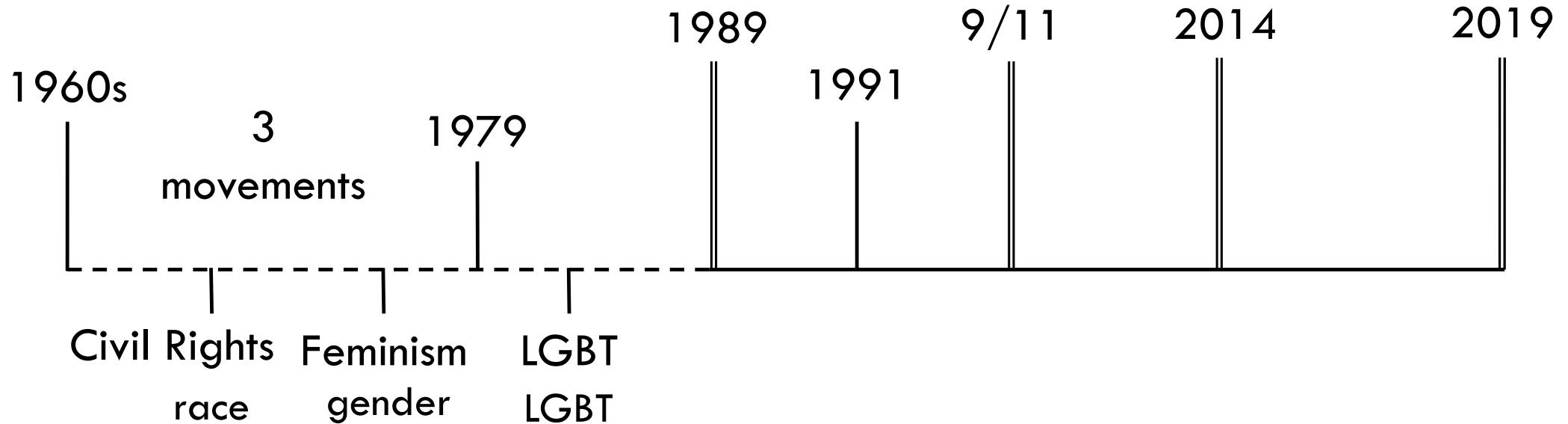

What are the 3 groups, in the 1989 time period? We started in 1989 and went back to the 1960s. What 3 movements did we see? The Civil Rights Movement: which is about race. Feminism: which is about gender. And the LGBT movement. That's the story of the 40 years prior to the Time of the End on our line, especially the last 20 years. So we have race, gender, and homosexuality.

# THE 3 GROUPS

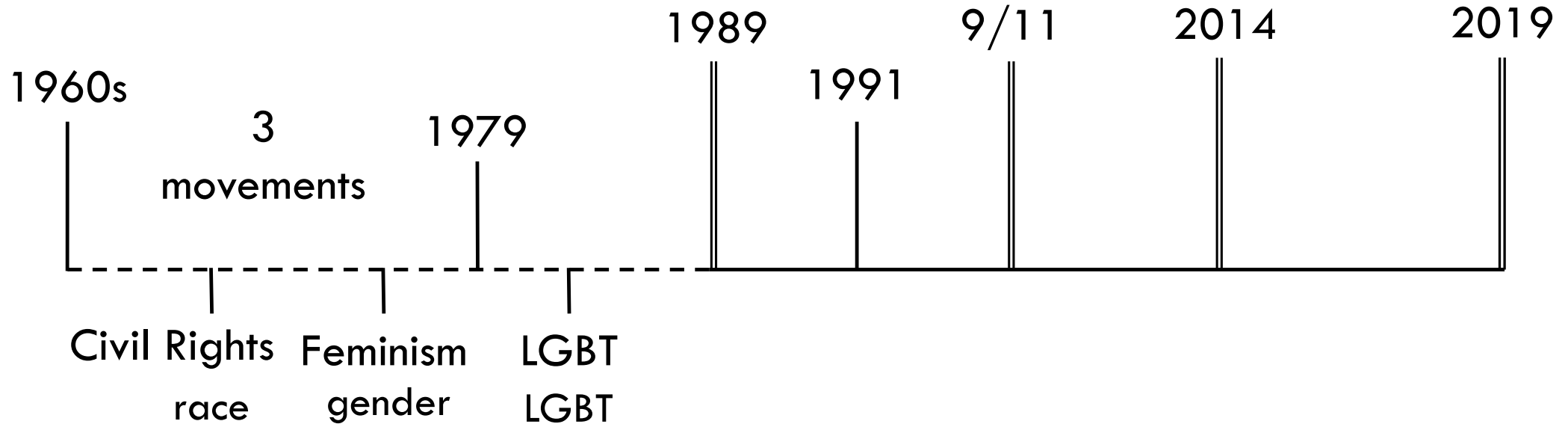

We saw, in a past presentation, how these 3 movements began our reform line. Because of these movements Ronald Reagan was made president and he was racist, sexist, and homophobic. He got elected by the Protestants and they controlled him; he was a conservative as well. These 3 movements are the issues that began our reform line.

# AFTER REAGAN

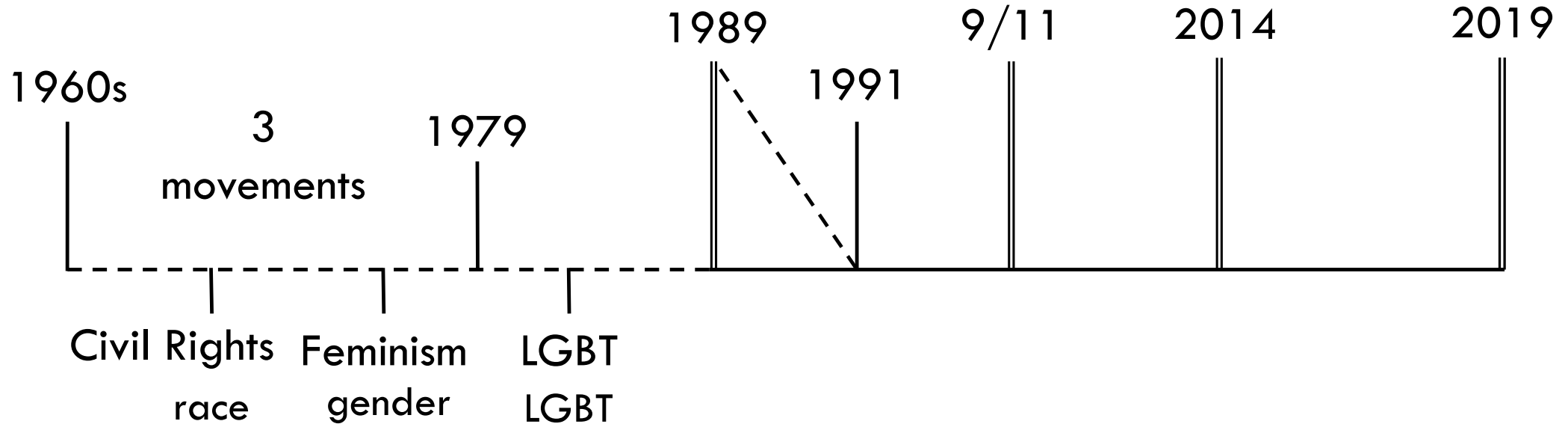

Steve Bannon says that under Reagan and Bush everything was good from 1989 to 1991 (as the Soviet Union was falling). Then, according to Steve Bannon everything went wrong; an example is president Obama. So in response to that the Protestant movement restarted in 2014.

# ALPHA AND OMEGA

The 1850 history is an Alpha history, and our history is an Omega history.

$\alpha$  1850  $\rightarrow$  Slavery - LAW

+ 1888  $\rightarrow$  Sunday - LAW

---

$\Omega$  "SL" - LAW



# MILLERITES

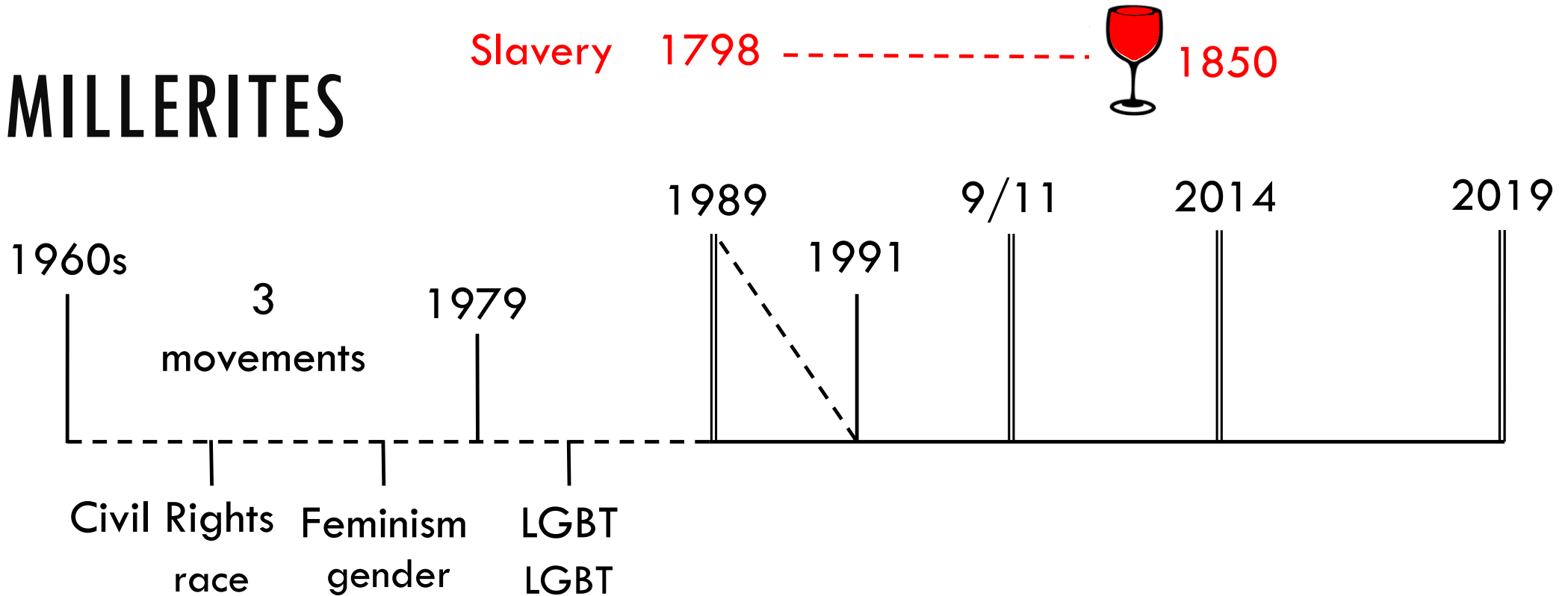

When was slavery an issue in the United States? Our Time of the End was typified by 1798, and 2014 by 1850 (in this application because both are Sunday laws). Long before the Time of the End slavery was a problem. That's one reason why in our time the Sunday Law can't be a Sabbath/Sunday issue. In the Alpha history slavery just built up (or the cup of the USA filled up) until 1850.

# MORAL MAJORITY

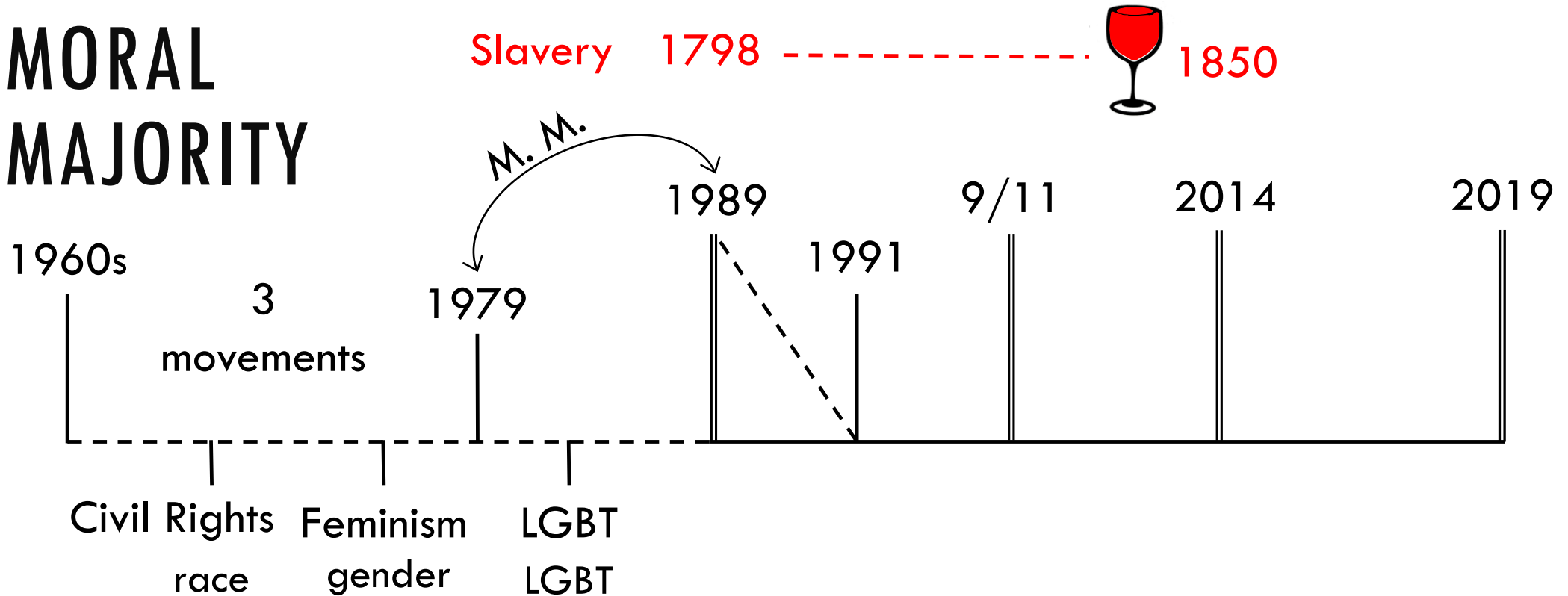

These subjects of equality existed before 1989 (the TOE) and they are what the Moral Majority was raised up to fight against from 1979 to 1989; the Protestants tried to stop those movements under Reagan. But in 2014 they revived with a lot of power and we've discussed a few things that they began to do.

# THE PROTESTANTS' PLAN

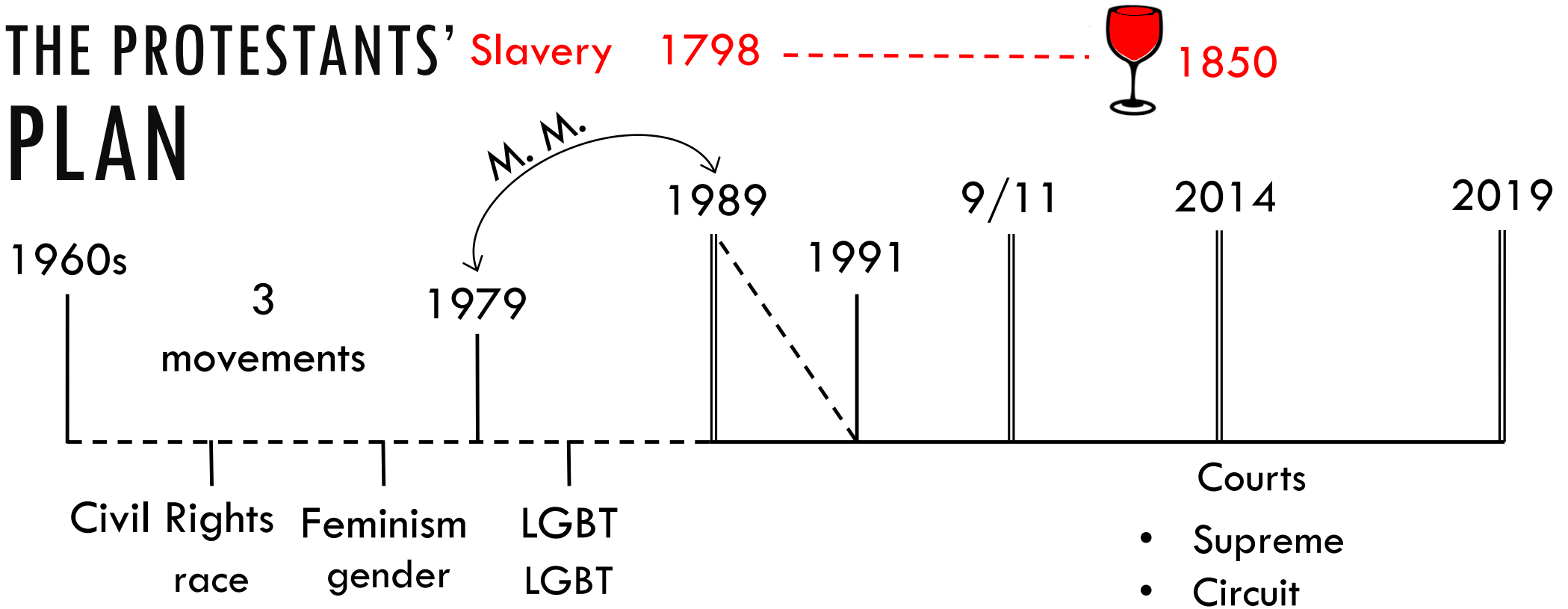

The first thing they had to do, before they could destroy these 3 movements, was take over the courts (the Supreme and the Circuits)- beginning under Mitch McConnell in 2014. And from Trump's election in 2016 until now the Evangelical Protestant movement has been taking down these 3 issues.

# RACE AND IMMIGRANTS

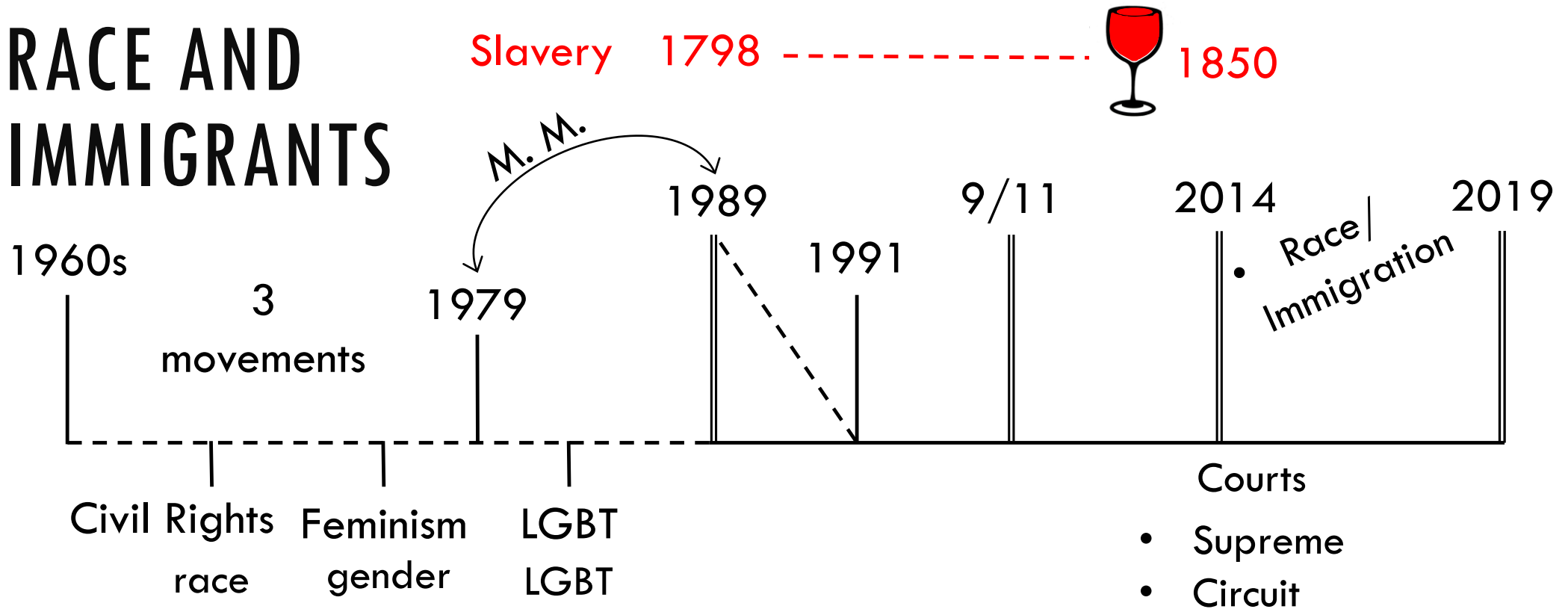

One issue is about immigration (and the rights of African Americans). For example the rights of African Americans who have been arrested and imprisoned (when a white person would not have been) to vote- that has been debated in the courts. So it isn't just about immigration- it's also about race and those both fall under nationalism.

# WOMEN AND HOMOSEXUALS

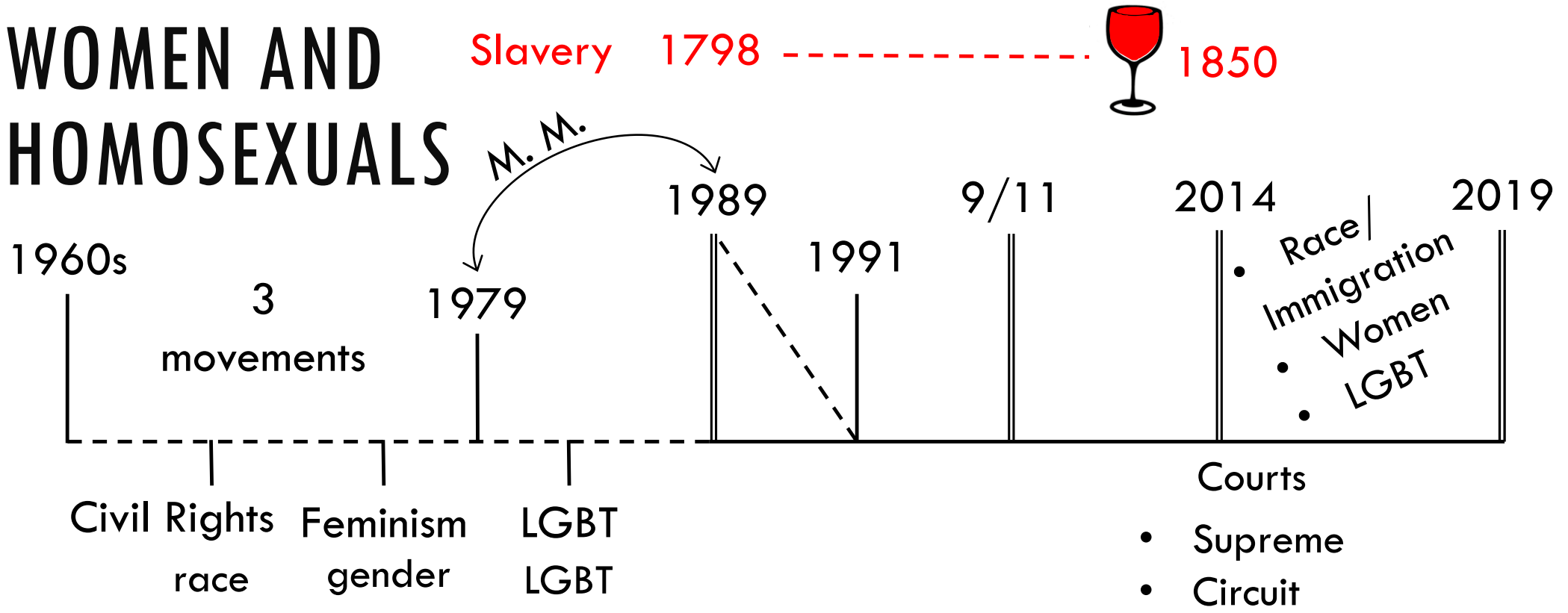

The second issue is the rights of women , and the third is the rights of homosexuals. Those three subjects have been hitting the court system since 2014; and that was planned- it wasn't an accident.

Many of those court cases were scheduled for this year.

# THE JUDICIAL SYSTEM



# TRUMP AND THE COURTS

The presidency of Donald Trump isn't the only change that has happened in the United States. The Judicial system has also changed- and that is the most serious. To us, that should matter, because we know what will happen at the Sunday Law. The Supreme Court used to stop the religious movements, and that happened under presidents like Reagan. It was the last line of defense but since 2014 it has not been able to do that. You can say it's had its deadly wound- it's not dead yet- but it can do things like approve travel bans now.

1850 → Slavery - LAW

+ 1888 → Sunday - LAW

---

“SL” - LAW



# ARTICLES TO READ

The first one is by *The Guardian* on March 10, 2019; and it's called "Trump's legacy: conservative judges who will dominate US Law for decades". We've talked about the Supreme Court and the Circuit Courts, but there are other courts. This article talks about 89 judges that Trump has appointed. Which far exceeds Barack Obama or George W. Bush.

There's another article, by *The Washington Post* also about this subject. It's titled "1 in every 4 court judges is now a Trump appointee". This one is from December 21, 2019; both articles are recognizing this around the same time- the same year. The first line in the Washington Post article says, "After three years in office, President Trump has remade the federal judiciary, ensuring a conservative tilt for decades...". In this article they also talk about other things related to the Judicial system.



# 3 ISSUES

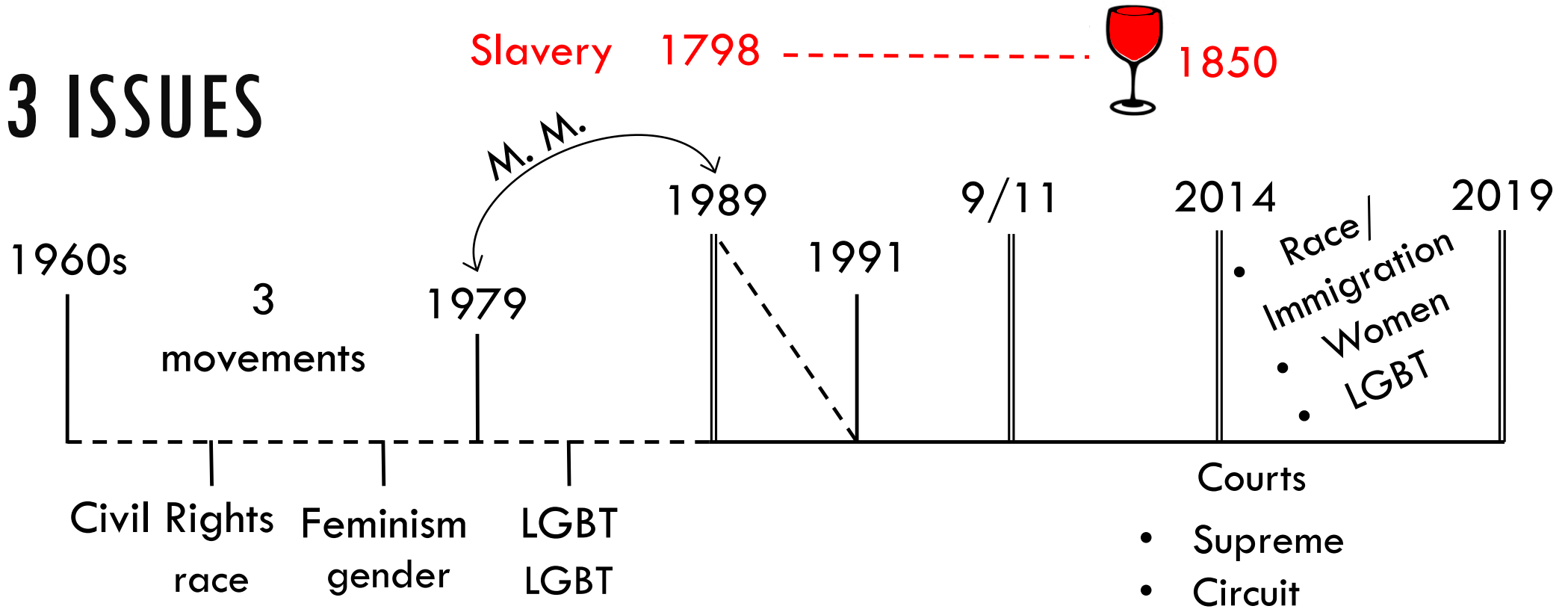

So what Elder Tess wanted us to see is how the Civil Rights Movement, the Feminist movement, and the LGBT movement began. Those are what were attacked by Protestantism (the Moral Majority) in the beginning of our reform line; those movements brought them together and made them start messing with politics. This also happened in 2014.

# THE COURTS

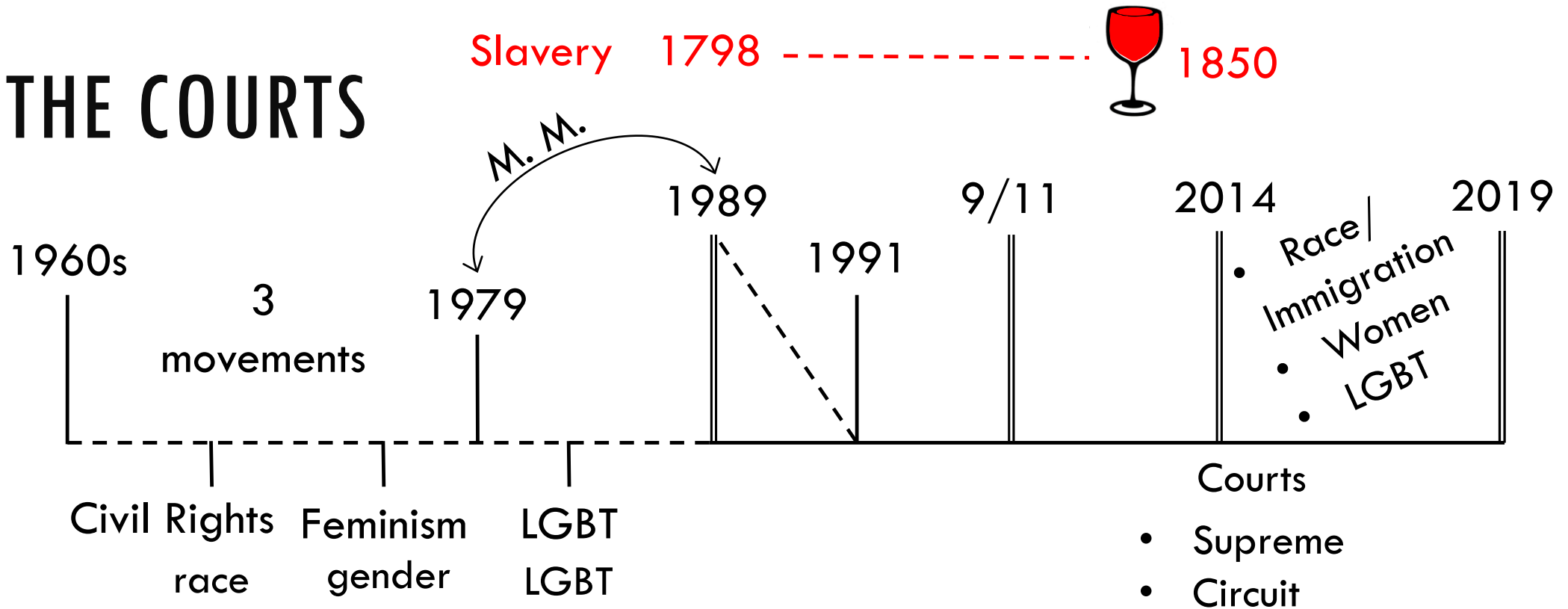

But they had failed in the pre 1989 time period. Yet since 2014 (thanks to Mitch McConnell) the Protestant movement has taken down the courts. And we know that the “Sunday Law”, in our time, comes through the courts. Also, currently these three issues that have to do with equality (immigration, [race] women’s rights, and LGBT rights) are being fought in the courts. The courts, though they have in the past, are no longer able to stop this religious/political movement that is pushing for inequality.

IN CONCLUSION



# EXTERNAL EVENTS

This (the history of 2014 to 2019) also connects to the line of Christ.

These events (between 2014 and 2019 that we listed) are just a fraction of the things going on, and they are being debated in the court system.

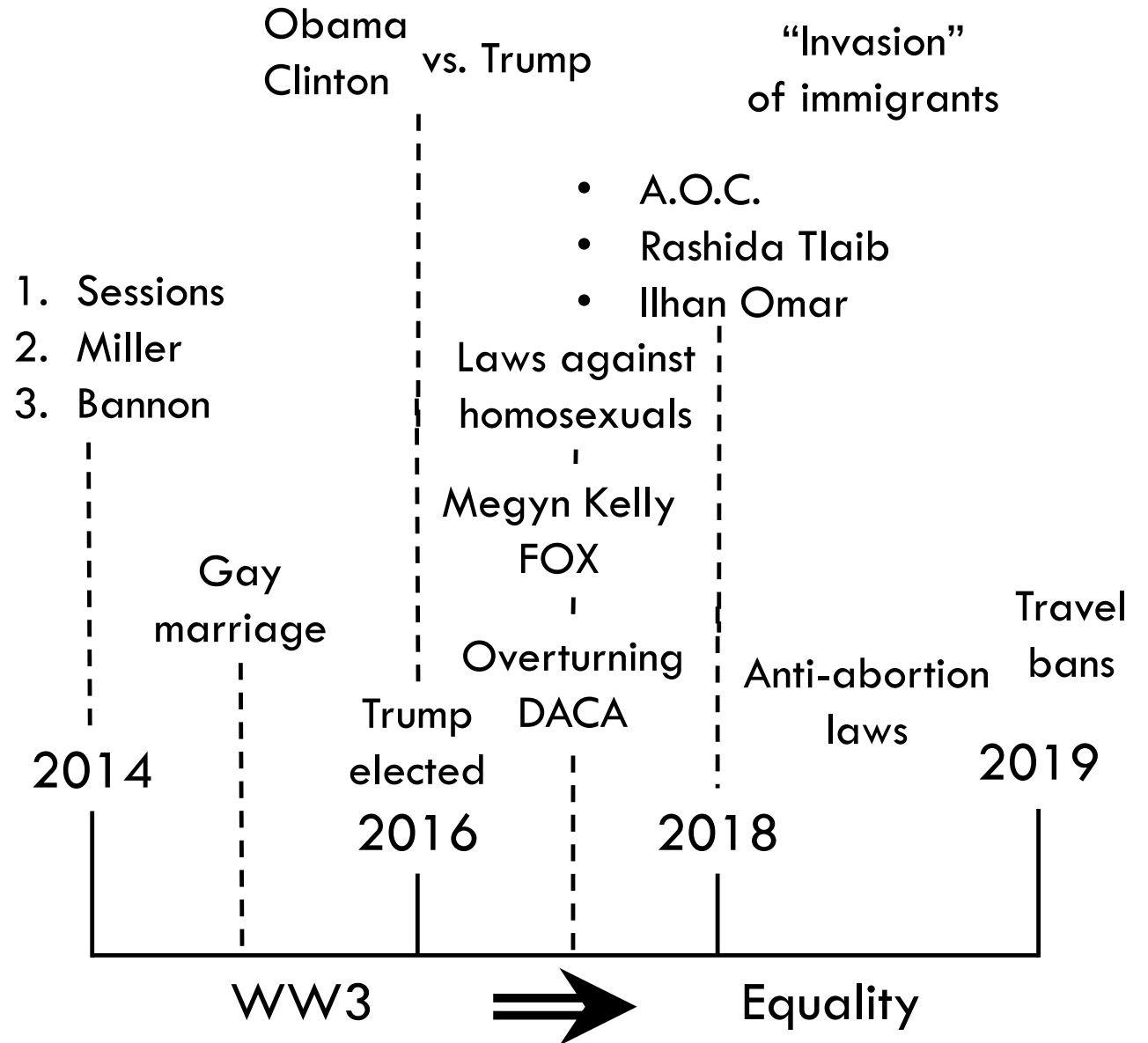

# THE CONSTITUTION

Even if having a balanced Supreme Court was addressed in the Constitution, people would still argue about what it says or what it means (like they do now). They will just read it differently; they will define liberal and conservative differently.

This is like presidential term limits; the Constitution didn't say only two terms- people just knew to only do that. So presidents only run for two terms, even though Constitutionally they could run for more- until Franklin D. Roosevelt. He was president from 1933 to 1945. People were panicking by the time he got to his fourth term (the election was in 1944). After he died, in 1945, a 2-term limit for presidents was added to the Constitution as the 22<sup>nd</sup> Amendment (it was approved by Congress in 1947 and ratified by the states in 1951). While everyone is behaving people don't think law is needed.

# TRUMP DID WHAT REAGAN WOULDN'T

Ronald Reagan appointed a somewhat liberal woman: Sandra Day O'Connor as a judge to the Supreme Court (she was the first woman on the court) and the Protestants didn't like that. But he didn't want to listen to them (he didn't even want to listen to the Pope), that's why everything went wrong. He did his own thing, he wasn't really under the Protestants' control. So he did some things right: like he kept the Supreme Court balanced when the Protestants' wanted it to be conservative. Trump is the only president who has been bold enough to break the Supreme Court balance, not even Reagan would do it.

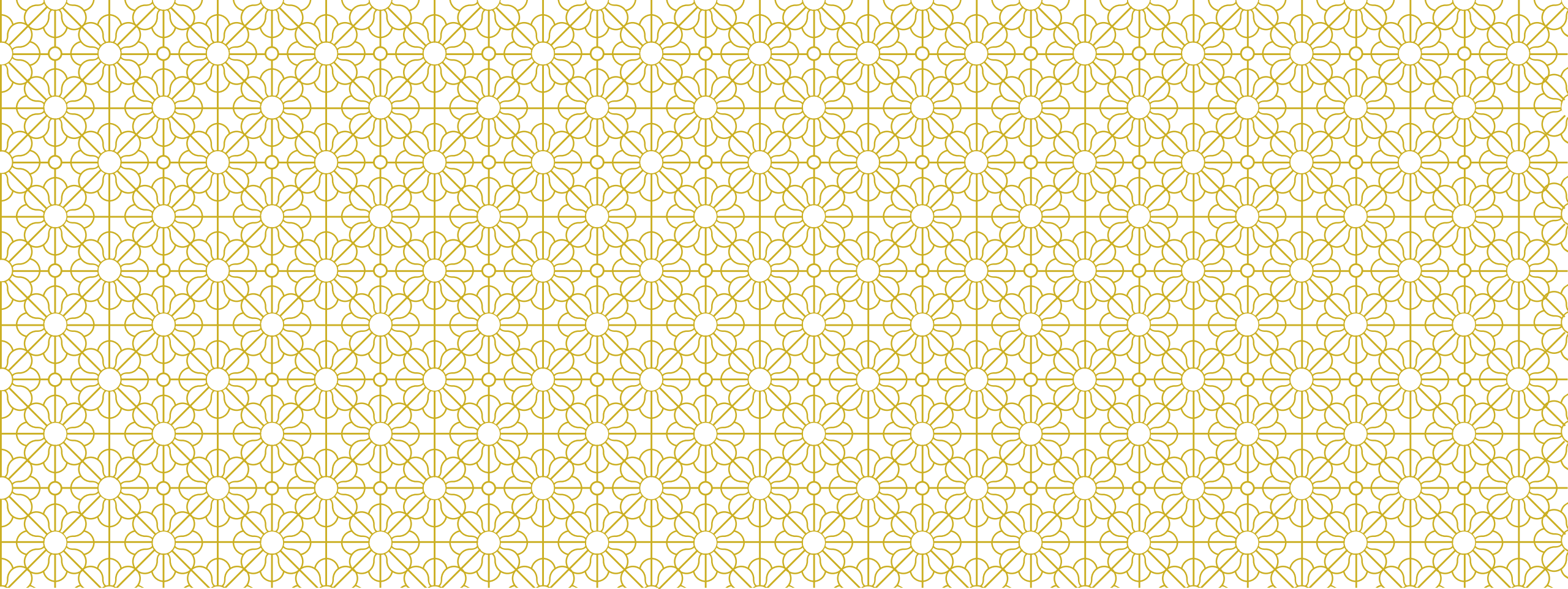

**RUTH BADER  
GINSBURG**

**The End**